

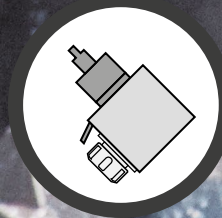

- BIGLIA
- BMT
- DMG MORI
- GOODWAY
- HAAS
- MAZAK
- MIYANO
- NAKAMURA
- OKUMA
- SPINNER
- TAKISAWA JAPAN
- TAKISAWA TAIWAN
- TSUGAMI



# 5

*Upgrade your lathe  
and boost productivity!*

**VDI e BMT DRIVEN TOOLS**

**Portautensili motorizzati / Driven Tools**

# INDICE - INDEX

## MOTORIZZATI - DRIVEN TOOLS

|   | pages                |   | pages                |
|---|----------------------|---|----------------------|
| <b>BIGLIA</b>                               | from 5.25<br>to 5.30 | <b>65</b>   |                      |
| <b>BMT55</b>                                |                      | <b>ASSIALE</b><br>AXIAL   |                      |
| <b>ASSIALE</b><br>AXIAL                     |                      | <b>RADIALE</b><br>RADIAL  | from 5.38<br>to 5.39 |
| <b>ASSIALE 2 USCITE</b><br>AXIAL 2 OUTPUTS  |                      | <b>RADIALE DOPPIO</b><br>RADIAL DOUBLE  |                      |
| <b>ASSIALE DISASSATO</b><br>AXIAL OFFSET    | from 5.28<br>to 5.30 | <b>RADIALE ARRETRATO</b><br>RADIAL OFFSET                                     |                      |
| <b>RADIALE</b><br>RADIAL                    |                      | <b>ORIENTABILE</b><br>ADJUSTABLE  |                      |
| <b>RADIALE DOPPIO</b><br>RADIAL DOUBLE      |                      | <b>75</b>   |                      |
| <b>ORIENTABILE</b><br>ADJUSTABLE            |                      | <b>ASSIALE</b><br>AXIAL   | from 5.40<br>to 5.41 |
| <b>PORTA CREATORE</b><br>DRIVEN GEAR HOBBER |                      | <b>RADIALE</b><br>RADIAL  |                      |
| <b>BMT</b>                                  | from 5.31<br>to 5.42 | <b>RADIALE DOPPIO</b><br>RADIAL DOUBLE  |                      |
| <b>45</b>                                   |                      | <b>ORIENTABILE</b><br>ADJUSTABLE  |                      |
| <b>ASSIALE</b><br>AXIAL                     |                      | <b>85</b>   |                      |
| <b>ASSIALE DISASSATO</b><br>AXIAL OFFSET    | from 5.34<br>to 5.36 | <b>ASSIALE</b><br>AXIAL   | at 5.42              |
| <b>RADIALE</b><br>RADIAL                    |                      | <b>RADIALE</b><br>RADIAL  |                      |
| <b>RADIALE DOPPIO</b><br>RADIAL DOUBLE      |                      | <b>DMG MORI</b>   | from 5.43<br>to 5.53 |
| <b>ORIENTABILE</b><br>ADJUSTABLE            |                      | <b>NL</b>   |                      |
| <b>55</b>                                   |                      | <b>ASSIALE</b><br>AXIAL   |                      |
| <b>ASSIALE</b><br>AXIAL                     |                      | <b>ASSIALE DISASSATO</b><br>AXIAL OFFSET                                      |                      |
| <b>ASSIALE DISASSATO</b><br>AXIAL OFFSET    | from 5.36<br>to 5.37 | <b>ASSIALE 2 USCITE</b><br>AXIAL  |                      |
| <b>RADIALE</b><br>RADIAL                    |                      | <b>RADIALE</b><br>RADIAL  | from 5.47<br>to 5.50 |
| <b>RADIALE DOPPIO</b><br>RADIAL DOUBLE      |                      | <b>RADIALE DOPPIO</b><br>RADIAL DOUBLE  |                      |
| <b>ORIENTABILE</b><br>ADJUSTABLE            |                      | <b>RADIALE ARRETRATO</b><br>RADIAL OFFSET                                     |                      |
|   |                      | <b>RADIALE DOPPIO 2 USCITE SU ASSE Y</b><br>DOUBLE RADIAL 2 OUTPUTS ON Y AXIS |                      |
|   |                      | <b>RADIALE 8 USCITE</b><br>8 OUTPUT RADIAL                                    |                      |
|   |                      | <b>ORIENTABILE</b><br>ADJUSTABLE  |                      |
|   |                      | <b>PORTA CREATORE</b><br>DRIVEN GEAR HOBBER                                   |                      |

# INDICE - INDEX

## MOTORIZZATI - DRIVEN TOOLS

|   | pages                |   | pages                |
|---|----------------------|---|----------------------|
| <b>NZ</b>   |                      | <b>BMT 65</b>   |                      |
| <b>ASSIALE</b><br>AXIAL                                 |                      | <b>ASSIALE</b><br>AXIAL                                 |                      |
| <b>ASSIALE 2 USCITE</b><br>AXIAL                        |                      | <b>RADIALE</b><br>RADIAL                                | from 5.62<br>to 5.63 |
| <b>RADIALE</b><br>RADIAL                                | from 5.51<br>to 5.52 | <b>RADIALE DOPPIO</b><br>RADIAL DOUBLE                  |                      |
| <b>RADIALE ARRETRATO</b><br>RADIAL OFFSET               |                      | <b>RADIALE ARRETRATO</b><br>RADIAL OFFSET               |                      |
| <b>RADIALE DOPPIO ARRETRATO</b><br>RADIAL DOUBLE OFFSET |                      | <b>ORIENTABILE</b><br>ADJUSTABLE                        |                      |
| <b>RADIALE DOPPIO</b><br>RADIAL DOUBLE                  |                      | <b>MAZAK</b>  | from 5.65<br>to 5.74 |
| <b>ORIENTABILE</b><br>ADJUSTABLE                        |                      | <b>QUICK TURN NEXUS 1</b>                               |                      |
| <b>SL/ZL/DL</b>   |                      | <b>ASSIALE DISASSATO</b><br>AXIAL OFFSET                |                      |
| <b>ASSIALE</b><br>AXIAL                                 |                      | <b>RADIALE</b><br>RADIAL                                | at 5.68              |
| <b>RADIALE</b><br>RADIAL                                | at 5.53              | <b>RADIALE DOPPIO</b><br>RADIAL DOUBLE                  |                      |
| <b>RADIALE DOPPIO</b><br>RADIAL DOUBLE                  |                      | <b>RADIALE ROVESCIAITO</b><br>RADIAL UPSIDE DOWN        |                      |
| <b>RADIALE ROVESCIAITO</b><br>RADIAL UPSIDE DOWN        |                      | <b>ORIENTABILE</b><br>ADJUSTABLE                        |                      |
| <b>ORIENTABILE</b><br>ADJUSTABLE                        |                      | <b>QUICK TURN NEXUS 2</b>                               |                      |
| <b>GOODWAY</b>  | from 5.55<br>to 5.57 | <b>ASSIALE DISASSATO</b><br>AXIAL OFFSET                |                      |
| <b>G1/G4</b>  |                      | <b>RADIALE</b><br>RADIAL                                |                      |
| <b>ASSIALE</b><br>AXIAL                                 | at 5.57              | <b>RADIALE DOPPIO</b><br>RADIAL DOUBLE                  | from 5.69<br>to 5.70 |
| <b>RADIALE</b><br>RADIAL                                |                      | <b>RADIALE ROVESCIAITO</b><br>RADIAL UPSIDE DOWN        |                      |
| <b>HAAS</b>   | from 5.59<br>to 5.63 | <b>RADIALE DOPPIO ARRETRATO</b><br>RADIAL DOUBLE OFFSET |                      |
| <b>VDI40</b>  |                      | <b>ORIENTABILE</b><br>ADJUSTABLE                        |                      |
| <b>ASSIALE</b><br>AXIAL                                 |                      |   |                      |
| <b>RADIALE</b><br>RADIAL                                | at 5.61              |   |                      |
| <b>ORIENTABILE</b><br>ADJUSTABLE                        |                      |   |                      |

# INDICE - INDEX

## MOTORIZZATI - DRIVEN TOOLS

|   | pages                |  | pages                |
|---|----------------------|--|----------------------|
| <b>MAZAK</b>  |                      | <b>Ø45</b>                             |                      |
| <b>QUICK TURN NEXUS 3</b>                               |                      | <b>ASSIALE</b><br>AXIAL                | at 5.79              |
| <b>ASSIALE DISASSATO</b><br>AXIAL OFFSET                | at 5.71              | <b>RADIALE</b><br>RADIAL               |                      |
| <b>RADIALE</b><br>RADIAL                                |                      |  |                      |
| <b>RADIALE DOPPIO</b><br>RADIAL DOUBLE                  |                      |  |                      |
| <b>RADIALE ROVESCIATO</b><br>RADIAL UPSIDE DOWN         |                      |  |                      |
| <b>ORIENTABILE</b><br>ADJUSTABLE                        |                      |  |                      |
| <b>QUICK TURN SMART</b>                                 |                      | <b>Ø54</b>                             |                      |
| <b>ASSIALE</b><br>AXIAL                                 | from 5.72<br>to 5.73 | <b>ASSIALE</b><br>AXIAL                | at 5.80              |
| <b>ASSIALE DISASSATO</b><br>AXIAL OFFSET                |                      |  |                      |
| <b>RADIALE</b><br>RADIAL                                |                      |  |                      |
| <b>RADIALE ARRETRATO</b><br>RADIAL OFFSET               |                      |  |                      |
| <b>RADIALE DOPPIO ARRETRATO</b><br>RADIAL DOUBLE OFFSET |                      |  |                      |
| <b>ORIENTABILE</b><br>ADJUSTABLE                        |                      |  |                      |
| <b>HYPER QUADREX</b>                                    |                      | <b>NAKAMURA</b>                        | from 5.81<br>to 5.86 |
| <b>ASSIALE DISASSATO</b><br>AXIAL OFFSET                | at 5.74              | <b>BMT44</b>                           | at 5.83              |
| <b>RADIALE</b><br>RADIAL                                |                      |  |                      |
| <b>RADIALE DOPPIO</b><br>RADIAL DOUBLE                  |                      |  |                      |
| <b>ORIENTABILE</b><br>ADJUSTABLE                        |                      |  |                      |
| <b>MIYANO</b>   | from 5.75<br>to 5.80 | <b>ASSIALE</b><br>AXIAL                | from 5.84<br>to 5.85 |
| <b>Ø38</b>  | at 5.78              | <b>RADIALE</b><br>RADIAL               |                      |
| <b>ASSIALE</b><br>AXIAL                                 |                      |  |                      |
| <b>RADIALE</b><br>RADIAL                                |                      |  |                      |
| <b>RADIALE DOPPIO ARRETRATO</b><br>RADIAL DOUBLE OFFSET |                      | <b>RADIALE DOPPIO</b><br>RADIAL DOUBLE | at 5.86              |
|   |                      | <b>ORIENTABILE</b><br>ADJUSTABLE       |                      |
|   |                      | <b>BMT65</b>                           |                      |
|   |                      | <b>ASSIALE</b><br>AXIAL                | at 5.86              |
|   |                      | <b>RADIALE</b><br>RADIAL               |                      |
|   |                      | <b>RADIALE DOPPIO</b><br>RADIAL DOUBLE |                      |
|   |                      | <b>ORIENTABILE</b><br>ADJUSTABLE       |                      |

# INDICE - INDEX

## MOTORIZZATI - DRIVEN TOOLS

|   | pages                |
|---|----------------------|
| <b>OKUMA</b>                              | from 5.87<br>to 5.93 |
| <b>VDI30</b>                              |                      |
| <b>ASSIALE</b><br>AXIAL                   | at 5.90              |
| <b>RADIALE ARRETRATO</b><br>RADIAL OFFSET |                      |
| <b>VDI40</b>                              |                      |
| <b>ASSIALE</b><br>AXIAL                   | at 5.91              |
| <b>RADIALE</b><br>RADIAL                  |                      |
| <b>BMT55</b>                              |                      |
| <b>ASSIALE</b><br>AXIAL                   |                      |
| <b>RADIALE</b><br>RADIAL                  | at 5.92              |
| <b>RADIALE DOPPIO</b><br>RADIAL DOUBLE    |                      |
| <b>ORIENTABILE</b><br>ADJUSTABLE          |                      |
| <b>BMT60</b>                              |                      |
| <b>ASSIALE</b><br>AXIAL                   | at 5.93              |
| <b>RADIALE</b><br>RADIAL                  |                      |
| <b>SPINNER</b>                            | from 5.95<br>to 5.98 |
| <b>BMT45</b>                              |                      |
| <b>ASSIALE</b><br>AXIAL                   | at 5.97              |
| <b>RADIALE</b><br>RADIAL                  |                      |
| <b>ORIENTABILE</b><br>ADJUSTABLE          |                      |
| <b>VDI25</b>                              |                      |
| <b>ASSIALE</b><br>AXIAL                   | at 5.98              |
| <b>RADIALE</b><br>RADIAL                  |                      |

|   | pages                  |
|---|------------------------|
| <b>TAKISAWA TAIWAN</b>  | from 5.99<br>to 5.101  |
| <b>ASSIALE</b><br>AXIAL   |                        |
| <b>RADIALE</b><br>RADIAL  | at 5.101               |
| <b>RADIALE DOPPIO</b><br>RADIAL DOUBLE  |                        |
| <b>ORIENTABILE</b><br>ADJUSTABLE  |                        |
| <b>TSUGAMI</b>  | from 5.103<br>to 5.108 |
| <b>BMT65</b>  |                        |
| <b>ASSIALE</b><br>AXIAL   |                        |
| <b>RADIALE</b><br>RADIAL  |                        |
| <b>RADIALE ARRETRATO</b><br>RADIAL OFFSET                                     | from 5.106<br>to 5.107 |
| <b>RADIALE DOPPIO ARRETRATO</b><br>RADIAL DOUBLE OFFSET                       |                        |
| <b>RADIALE DOPPIO 2 USCITE SU ASSE Y</b><br>DOUBLE RADIAL 2 OUTPUTS ON Y AXIS |                        |
| <b>ORIENTABILE</b><br>ADJUSTABLE  |                        |
| <b>STOZZATORE</b><br><b>MOTORIZZATO</b><br>MOTORIZED SLOTTER                  | from 5.109<br>to 5.122 |
| <b>PORTA INSERTO</b><br>INSERT HOLDER   | from 5.111<br>to 5.116 |
| <b>INSERTI</b><br>INSERTS   | from 5.117<br>to 5.122 |

**Novità / News**

# Motorizzati / Driven tools

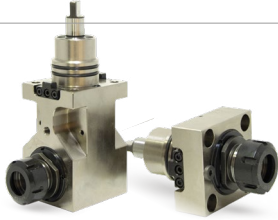

## Biglia lathes

Nuova gamma di motorizzati BMT44 ad alte prestazioni  
New high performance range BMT44

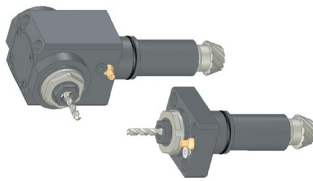

## Goodway lathes

Nuova gamma di motorizzati G1 e G4 per torni GOODWAY  
New range G1 and G4 Driven tools for Goodway lathes



## Mazak lathes

Nuovi modelli QTS e HQ  
New driven tools for QTS and HQ lathes



## Okuma lathes

Nuove ampie gamme di motorizzati per torni OKUMA VDI40 - BMT55  
New wide ranges of Driven tools for OKUMA VDI40 and BMT65 lathes

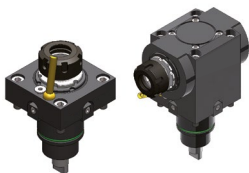

## Spinner lathes

Nuove ampie gamme di motorizzati per torni SPINNER VDI30 - BMT45  
New wide ranges of Driven tools for SPINNER VDI30 and BMT45 lathes

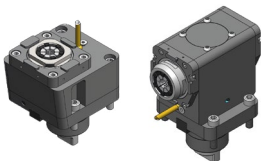

## Takisawa Japan lathes

Nuove gamme per torni TAKISAWA TAIWAN & TAKISAWA JAPAN  
New range for TAKISAWA TAIWAN & TAKISAWA JAPAN

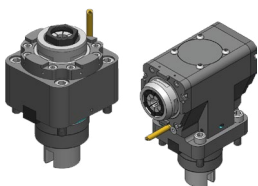

## Takisawa Taiwan lathes

Nuova gamma di motorizzati per torni TAKISAWA TAIWAN lathes  
New range of Driven Tools for TAKISAWA TAIWAN lathes

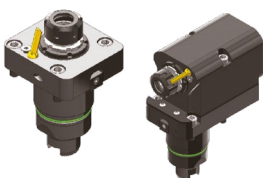

## Tsugami lathes

Nuovi Codici e Modelli Disponibili  
New Codes and types available







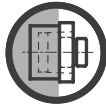
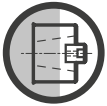
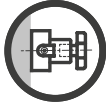

## SIMBOLI TIPOLOGIE MOTORIZZATI

### DRIVEN TOOLS DESIGN LOGOS

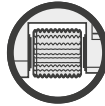
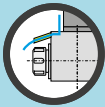
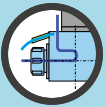
|   |   |   |   |   |  |   |   |
|---|---|---|---|---|--|---|---|
|  |  |  |  |  |  |  |  |
| <b>Assiale</b><br>Axial   | <b>Assiale doppio</b><br>Double Axial   | <b>Disassato</b><br>Offset Axis   | <b>Disassato Doppio</b><br>Double Offset Axis                                     | <b>Radiale</b><br>Radial  | <b>Radiale Doppio</b><br>Double Radial   | <b>Radiale 4 Uscite</b><br>Radial 4 Outputs   | <b>Radiale 8 Uscite</b><br>Radial 8 Outputs   |
|  |  |  |  |  |  |   |   |
| <b>Radiale Rovesciato</b><br>Radial Upside Down                                   | <b>Arretrato</b><br>Rear Offset   | <b>Arretrato Doppio</b><br>Double Rear Offset                                     | <b>Orientabile ±90°</b><br>Adjustable ±90°  | <b>Portacreatore</b><br>Driven Gear Hobber  |  |   |   |

## SIMBOLOGIA DATI TECNICI

### TECHNICAL DATA LOGOS

|  |   |   |   |  |   |  |
|--|---|---|---|--|---|--|
| <b>USCITA</b><br>OUTPUT                  |  |  |  |  |  |       |
|  | <b>Uscita HSK</b><br>HSK output   | <b>Uscita ISO</b><br>ISO output   | <b>Uscita portafresa</b><br>Shell mill holder output                                | <b>Uscita WELDON</b><br>WELDON output  | <b>Uscita CAPTO</b><br>CAPTO output   | <b>Portacreatore</b><br>Driven Gear Hobber   |
| <b>PASSAGGIO REFRIGERANTE</b><br>COOLANT |   |   |   |  |  |       |
|  |   |   |   | <b>Refrigerante Esterno</b><br>External Coolant                                      | <b>Refrigerante Interno</b><br>Internal Coolant                                       | <b>Refrigerante Interno</b><br>Internal Coolant  |
|  |   |   |   |  | <b>20 / 25 / 80</b><br><b>100bar</b>  | <b>ReCool NUT</b>  |
| <b>USCITA</b><br>OUTPUT                  |   |   |  |  |  |       |
|  |   |   | <b>Rapporto</b><br>Ratio  | <b>Rotazione uguale al mandrino</b><br>Rotation same as machine spindle              | <b>Rotazione opposta al mandrino</b><br>Rotation opposite as machine spindle          | <b>Rotaz. uguale ed opposta al mandrino</b><br>Rotation same & opposite as machine spindle |

## Portautensili Motorizzati / Driven tools

# VDI & BMT

**Più di 1000 modelli disponibili - More than 1000 types available**



Velocità / High-speed  
**24.000 Rpm**



Internal coolant  
fino a / Up to  
**100 Bar**

### USCITE MULTIPLE MULTIPLE OUTPUTS

Tutti i motorizzati, ad esclusione di quelli ad angolo variabile, possono essere forniti con doppia pinza contrapposta anche di pari grandezza. Sono stati realizzati per i modelli di tornio più recenti anche motorizzati assiali con doppia / tripla uscita frontale e radiali doppia uscita frontale.

All the driven tools, with the exception of those with adjustable angle, can be supplied with double or multiple output even of the same dimension. Multiple outputs can be opposite or with the same direction.

### ALTA VELOCITÀ RATIO 1:4 HIGH SPEED RATIO 1:4

(Opzione di moltiplica del numero di giri dalla torretta del tornio da 2 a 4 volte). Su richiesta, quasi tutti i modelli di motorizzati sono fornibili con velocità di rotazione fino a 24.000 Rpm. Questa soluzione permette di adeguare il numero di giri della torretta alle velocità di taglio delle nuove tipologie di utensili in commercio. Il sistema epicicloidale (interno) consente di mantenere inalterate le dimensioni di ingombro dei vari modelli, senza quindi penalizzare in alcun modo la funzionalità della macchina.

**N.B: I motorizzati standard con rapporto 1:1 hanno regime di rotazione Max. 12.000 Rpm.**

All the driven tools types are available with speed until 24.000 Rpm. There is also the possibility of speed increaser from 2 to 4 times thus adapting the Rpm of the turret drive to the speed of today's cutting tools. The epicyclic speed increaser system (a system of satellite gears) is self contained in the standard head overall dimensions and guarantees the same standards of quality and reliability.

**Attention: The standard rotary tools with 1:1 ratio have a Max Speed of 12.000Rpm**



Radiale 8 uscite  
Radial 8 outputs



Radiale doppio  
Double radial



### Perno eccentrico Eccentric pin

Nuovo perno di regolazione eccentrico per il posizionamento preciso ed accurato del motorizzato sulla torretta (per modelli Mazak QTN).

New eccentric regulation pin for an accurate positioning of the driven tool on the turret. (for Mazak QTN models).



### Maschiatura Tapping

Per le operazioni di maschiatura, tutti i nostri motorizzati possono utilizzare pinze compensate ET-1 perfettamente intercambiabili con le normali pinze secondo norma DIN 6499. Esse consentono una compensazione assiale da 7 a 13 mm a seconda della grandezza per recuperare eventuali errori di avanzamento e per l'inversione della rotazione.

For tapping operations all driven tools can be equipped with axially compensated collets ET-1 interchangeable with the standard ER collets according to the international standard DIN 6499. They allow the tap an axial compensation from 7 to 13 mm according to their size in order to compensate any feed error and the inversion of the rotation of direction.



### Cuscinetti Ball Bearings

Cuscinetti di precisione a contatto obliquo, precaricati, e lubrificati con grasso a vita.

Preloaded angular contact ball bearings precision and long life lubrication.



### Ingranaggi Gleason Gleason Spiral bevel

Conica di ingranaggi spirodali Gleason con evolvente rettificato ottimizzato

Gleason spiral bevel gears with completely ground involute form

I portautensili motorizzati per centri di tornitura a controllo numerico consentono di eseguire lavorazioni di fresatura, foratura e maschiatura sul tornio stesso e senza ulteriori piazzamenti. Anche in questo caso Gerardi propone un'ampia gamma di modelli, adatti ad attrezzare i torni e le torrette motorizzate dei maggiori costruttori di torni a livello mondiale con un rapporto qualità/prezzo insuperabile.

Driven tools for CNC turning centres allows milling, drilling and tapping operations on the lathes without additional parts handling. Also in this case Gerardi can supply a wide range of types in order to equip the CNC lathes and turrets of the most popular builders on the market with an unbeatable price/quality ratio.

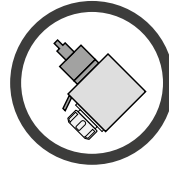

SCAN IT TO SEE



THE WEB PAGE



*Upgrade your lathe  
and boost productivity!*



Presi di moto intercambiabile per le varie tipologie di torrette Haas  
Interchangeable couplings for the different Haas turret

USCITE DISPONIBILI  
AVAILABLE  
OUTPUTS

PORTAFRESA  
TOOLHOLDER

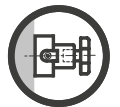

CAPTO



HSK

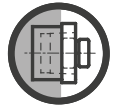

WELDON



ISO

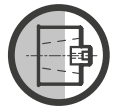

PORTACREATORE  
DRIVEN GEAR  
HOBBER

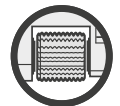

5

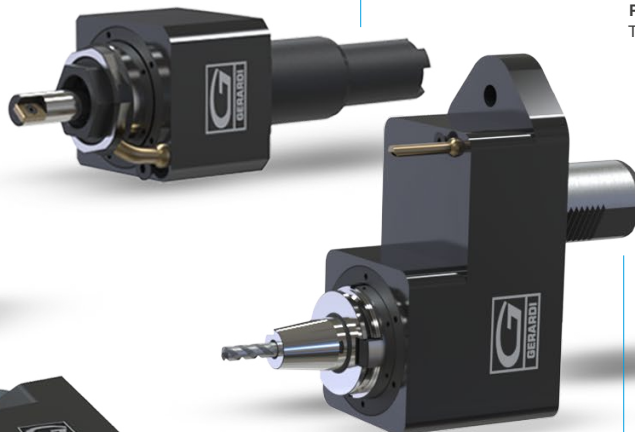

Attacco VDI  
VDI attachment

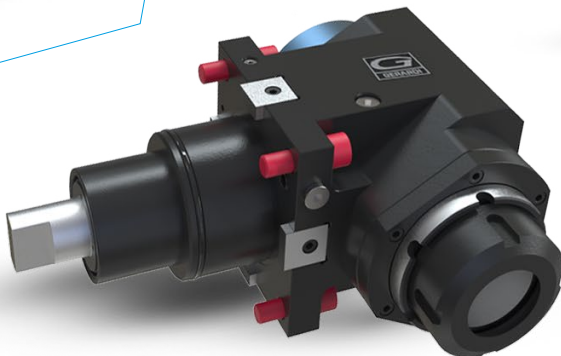

Attacco BMT  
BMT Attachment

Esterno  
External

MAX  
10bar

- » Mandrino Macchina
- » Corpo Motorizzato
- » Ugello

- » Machine Spindle
- » Driven Tool Body
- » Coolant Pipe



Interno  
Internal

MAX  
100bar

- » Mandrino Macchina
- » Corpo Motorizzato
- » Distributore
- » Utensile

- » Machine Spindle
- » Driven Tool Body
- » Rotating Distributor
- » Tool



Re-Cool Nut  
Ghiera Re-Cool

MAX  
150bar

- » Mandrino Macchina
- » Corpo Motorizzato
- » Ghiera Re-Cool
- » Utensile

- » Machine Spindle
- » Driven Tool Body
- » Re-Cool Nut
- » Tool



**DENOMINAZIONE UTENSILE**  
**TOOL DESIGNATION**

**Montaggio TANGENZIALE - OD Mounting**

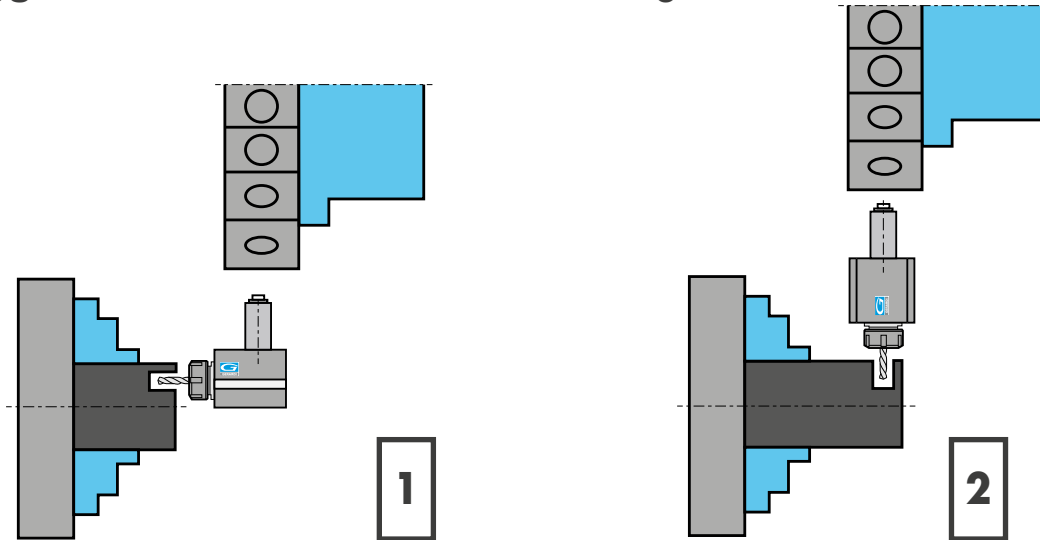

**1** Motorizzato **RADIALE** per lavorazioni assiali  
 RADIAL driven tool for axial machining

**2** Motorizzato **ASSIALE** per lavorazioni radiali  
 AXIAL driven tool heads for radial machining

5

**Montaggio FRONTALE - FACE Mounting**

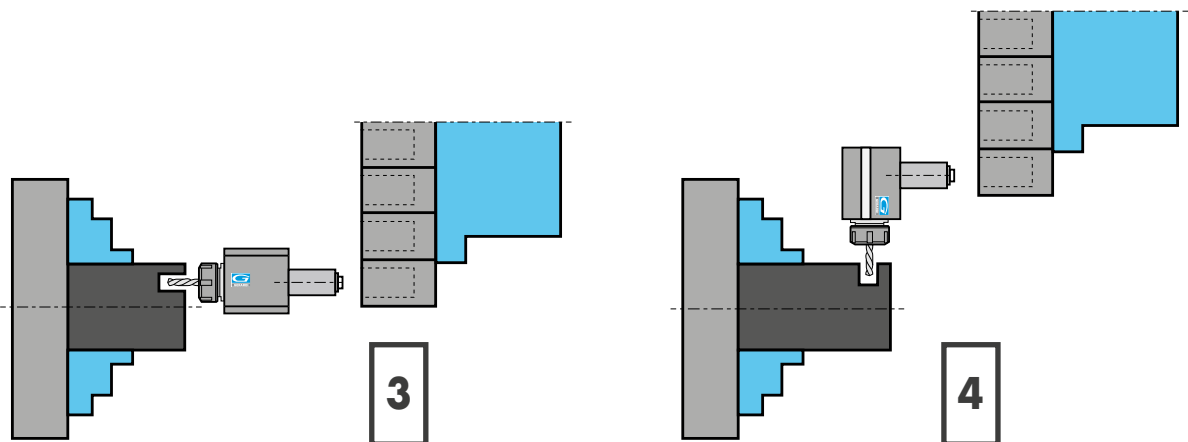

**3** Motorizzato **ASSIALE** per lavorazioni assiali  
 AXIAL driven tool for axial machining

**4** Motorizzato **RADIALE** per lavorazioni radiali  
 RADIAL driven tool heads for radial machining

## MOTORIZZATI RADIALI PER LAVORAZIONI ASSIALI RADIAL DRIVEN TOOLS FOR AXIAL MACHINING

### Montaggio TANGENZIALE - OD Mounting

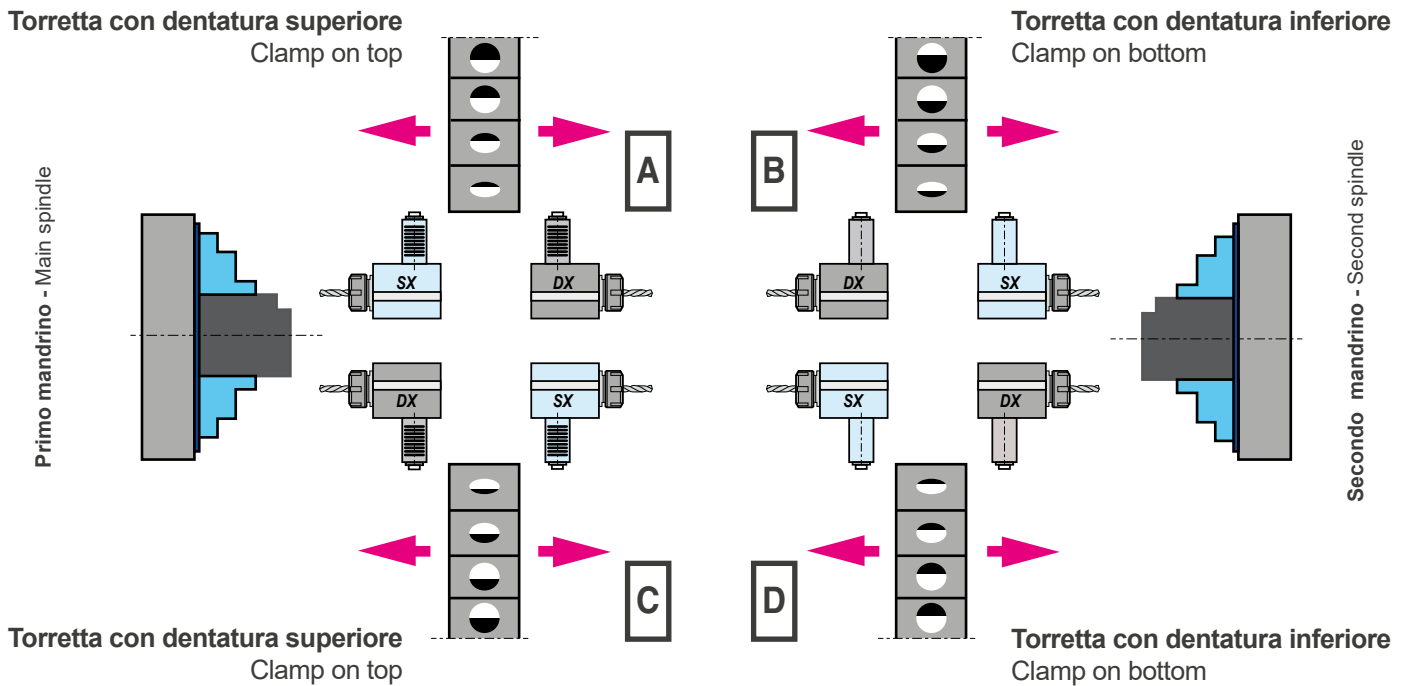

## MOTORIZZATI RADIALI PER LAVORAZIONI RADIALI RADIAL DRIVEN TOOLS FOR RADIAL MACHINING

### Montaggio FRONTALE - FACE Mounting

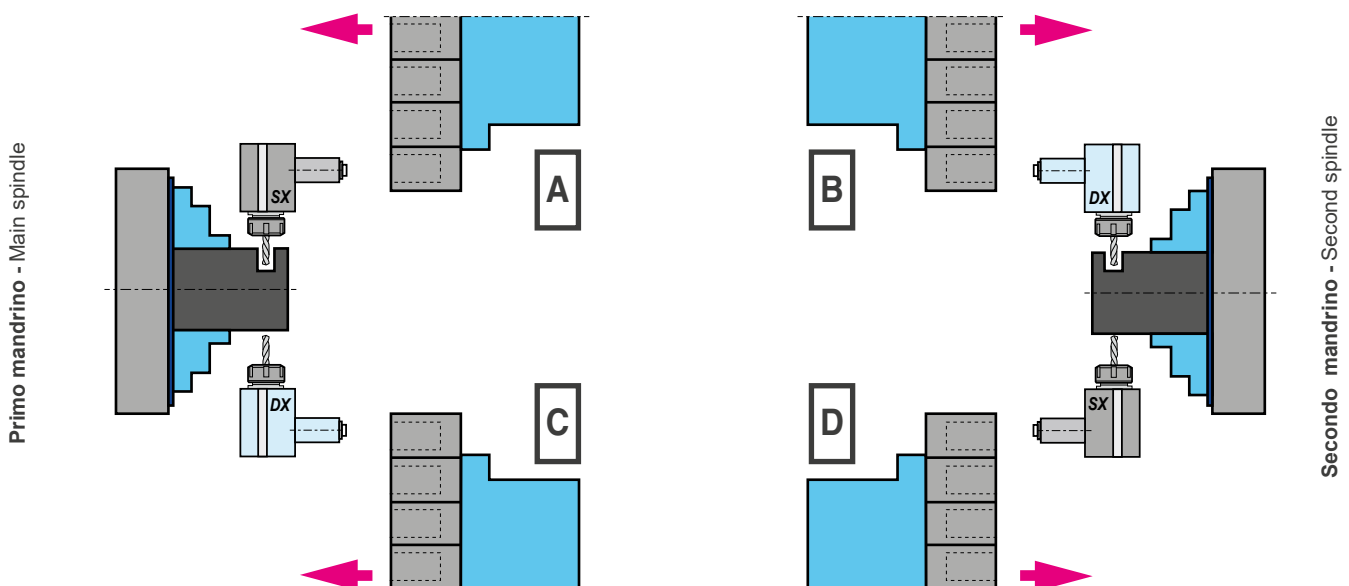

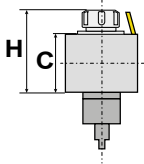
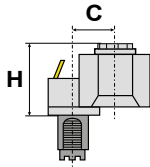
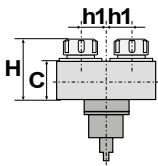
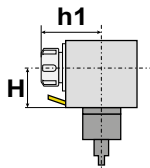
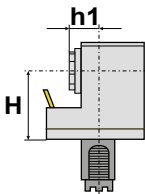
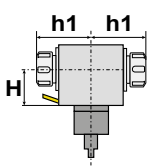
| <b>FORMA<br/>SHAPE</b>                             | <b>DESCRIZIONE<br/>DESCRIPTION</b>  | <b>APPLICAZIONE<br/>APPLICATION</b>   |   |
|--|---|---|---|
| <b>Assiale</b><br><br>Axial                        | <b>L'asse dell'utensile è in linea all'asse della torretta o del mandrino</b><br><br>The tool axis is aligned to the turret or spindle axis   | <b>Lavorazioni di foratura, fresatura o maschiatura sulla faccia frontale del pezzo</b><br><br>Drilling, milling or tapping operations on the frontal side of the workpiece   |    |
| <b>Assiale Disassato</b><br><br>Offset Axial       | <b>L'asse dell'utensile è in linea ma traslato rispetto all'asse della torretta</b><br><br>The tool axis is aligned with, but offset from, the turret axis  | <b>Lavorazioni frontali su flange di grande diametro o in situazioni in cui serve gestire spazi ristretti</b><br><br>Front-facing machining on large-diameter flanges or in situations where tight spaces need to be managed  |    |
| <b>Assiale 2 Uscite</b><br><br>Axial 2 Outputs     | <b>Un corpo unico ospita due uscite parallele orientate nella stessa direzione in linea con l'asse torretta</b><br><br>A single body contains two parallel outputs facing the same direction, aligned with the turret axis                      | <b>Aumento delle potenziali posizioni di una torretta e possibilità di fare due diverse lavorazioni contemporaneamente</b><br><br>Increased number of potential positions on a turret and the possibility of performing two different machining operations simultaneously |    |
| <b>Radiale</b><br><br>Radial                       | <b>L'asse dell'utensile è perpendicolare all'asse della torretta o del mandrino</b><br><br>The tool axis is perpendicular to the turret or spindle axis   | <b>Lavorazioni di foratura, fresatura o maschiatura sul diametro esterno del pezzo</b><br><br>Drilling, milling or tapping operations on the outer diameter of the workpiece  |   |
| <b>Radiale Arretrato</b><br><br>Rear Offset Radial | <b>L'asse dell'utensile è perpendicolare all'asse della torretta o del mandrino ma traslato verso il corpo del motorizzato</b><br><br>The tool axis is perpendicular to the axis of the turret or spindle but offset towards the motorised unit | <b>Lavorazioni sul diametro esterno di un pezzo di grandi dimensioni o in situazioni in cui serve gestire spazi ristretti</b><br><br>Machining on the outer diameter of a large workpiece or in situations where tight spaces need to be managed                          |  |
| <b>Radiale Doppio</b><br><br>Double Radial         | <b>Il motorizzato ha due uscite situate sullo stesso asse radiale, ma rivolte in direzioni opposte</b><br><br>The driven tool has two outputs situated on the same radial axis, but facing in opposite directions                               | <b>Esecuzione di due operazioni radiali diverse (es. sgrossatura e finitura) spostando solo l'asse X e Z del tornio</b><br><br>Performing two different radial operations (e.g. roughing and finishing) by moving only the X and Z axes of the lathe                      |  |

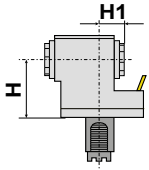
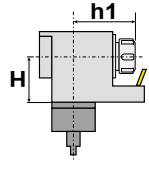
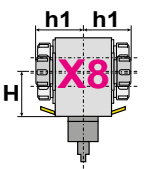
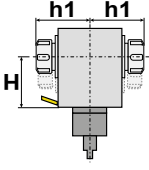
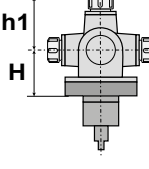
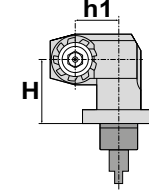
| <b>FORMA</b><br><b>SHAPE</b>  | <b>DESCRIZIONE</b><br><b>DESCRIPTION</b>  | <b>APPLICAZIONE</b><br><b>APPLICATION</b>   |   |
|---|---|---|---|
| <b>Radiale Doppio Arretrato</b><br><br>Double Rear Offset Radial                  | <b>Le due uscite sono spostate all'indietro rispetto all'asse centrale del gambo</b><br><br>The two outputs are set back from the central axis of the stem  | <b>Esecuzione di due operazioni radiali diverse e possibilità di maggior gestione delle situazioni in cui serve gestire spazi ristretti</b><br><br>Performing two different radial operations and greater flexibility in handling situations where working in tight spaces is required              |    |
| <b>Radiale Rovesciato</b><br><br>Radial Upside Down                               | <b>L'asse dell'utensile è perpendicolare all'asse della torretta o del mandrino ma con il tagliente rivolto in direzione opposta</b><br><br>The tool axis is perpendicular to the axis of the turret or spindle, but with the cutting edge facing in the opposite direction                 | <b>Lavorazioni di foratura, fresatura o maschiatura sul diametro esterno del pezzo da effettuare sul contromandrino</b><br><br>Drilling, milling or tapping operations on the outer diameter of the workpiece to be carried out on the sub-spindle  |    |
| <b>Radiale 8 Uscite</b><br><br>Radial 8 Outputs                                   | <b>Il corpo del motorizzato è simmetrico rispetto all'asse della torretta e presenta 4 uscite sul lato sinistro e 4 uscite sul lato destro</b><br><br>The driven tool body is symmetrical in relation to the turret axis and has 4 outputs on the left side and 4 outputs on the right side | <b>Ideale per torni con poche posizioni. Drastica riduzione del fermo macchina con quattro lavorazioni contemporanee possibili</b><br><br>Ideal for lathes with limited positioning. Significant reduction in machine downtime, with the possibility of carrying out four operations simultaneously |    |
| <b>Radiale Doppio 2 Uscite su Asse Y</b><br><br>Double Radial 2 Outputs on Y-axis | <b>Due coppie di uscite parallele tra loro e distanziate lungo l'asse Y della macchina</b><br><br>Two pairs of outputs arranged in parallel and spaced apart along the machine's Y-axis   | <b>Entrambi i lati consentono di fare due lavorazioni e cambiare velocemente spostando asse Y senza rotazione torretta</b><br><br>Both sides allow the machine to perform two operations and change quickly by moving the Y-axis without rotating the turret  |  |
| <b>Orientabile</b><br><br>Adjustable  | <b>Permettono di inclinare l'asse dell'utensile secondo un angolo specifico richiesto dalla lavorazione</b><br><br>They allow the tool axis to be tilted to a specific angle required for the machining operation   | <b>Fori inclinati, smussi o lavorazioni su facce non ortogonali</b><br><br>Angled holes, chamfers or machining on non-perpendicular surfaces  |  |
| <b>Porta Creatore</b><br><br>Gear Hobber  | <b>Dotato di una fresa specifica (creatore) su un albero rigido, montato su un supporto basculante</b><br><br>Equipped with a specific milling cutter on a rigid shaft, mounted on a pivoting support   | <b>Dentatura di ingranaggi cilindrici, elicoidali o viti senza fine direttamente in macchina, eliminando la ripresa su dentatrice</b><br><br>Cutting of cylindrical, helical or worm gears directly on the machine, eliminating the need for a second pass on a gear cutting machine                |  |

# COMPATIBILITÀ MOTORIZZATI

## DRIVEN TOOLS COMPATIBILITY

In fase d'ordine specificare: **CoSTRUTTORE, MODELLO & N° POSIZIONE TORRETTA**

In case of order please specify **MACHINE BUILDER, MODEL & TURRET N°**

| Costruttore<br>Builder Brand | Torretta<br>Turret | Modelli Macchina<br>Lathe or turret Models   | LP06<br>Pages     |
|------------------------------|--------------------|--|-------------------|
| <b>DIN5480</b>               | <b>VDI</b>         | <b>VDI 20, 25, 30, 40, 50, 60</b>  |                   |
| Accuway                      | VDI 30             | UT-100 M   |                   |
| Avia                         | VDI 30             | 30M  |                   |
| Benzinger                    | VDI 20             | DOLittle B2, TNC-S   |                   |
|                              | VDI 25             | TNI   TCM - B4   Take 5   GO Future  |                   |
| Dmg Mori                     | VDI 25             | NZ Due, Tre, Quattro (VDI25)   Sprint 50   CTX alpha VDI25   |                   |
|                              | VDI 30             | CTX 350 4A, 350 V6 (16 ST)   T1   CTX 350 V6   CTX 350 V3/V4   NZ Due, Tre, Quattro   CTX 2500   CTX alpha / beta   CLX 350/450 V6   CTX beta VDI30 radial turret   CTX alpha VDI30 radial turret   Sprint 65   NZ 1500, 2000   NLX/ NL 1500,2000,2500   NEF 400   CTX beta VDI30 axial turret   CTX alpha VDI30 axial turret   CTV 160   CLX 350 V1/V3/V4, ecoTurn 310                                  |                   |
|                              | VDI 40             | TVDI40   T2   CTX beta/gamma 4A   CTX beta   CTX 2500   CLX 450/550/750 V6   CTX 510   CTX 450 / 510 ECOLINE   CTX beta VDI40 axial turret   CTX 2500 VDI40 axial turret   CLX 450/550 V1/V3/V4, ecoTurn 450/510   NL/NLX 1500, 2000, 2500 Y/SY VDI40   NEF 600   CTX gamma VDI40 radial turret   CTX gamma VDI40 axial turret   CTX beta VDI40 radial turret   CTV 200, 250, 315 linear   CTV 160 VDI40 |                   |
|                              | VDI 50             | CTX gamma VDI50 radial turret   CTX 750 V6 VDI50   CTX gamma VDI50 axial turret   CTX beta VDI50 axial turret   CLX/CTX 750 V1/ V3/V4, ecoTurn 650   CTV 400 linear  |                   |
| Emco                         | VDI 25             | Maxxturn 45 SM/SMY/G2 DIN5480   EMCOTURN 332MC DIN5480   Hyperturn 45 DIN5480   EMCOTURN E45 SM/SMY DIN5480   Hyperturn 45 (VDI25)   EMCOTURN E45 SM/SMY (VDI25)   EMCOTURN 332MC   Maxxturn 45 M DIN5480  |                   |
|                              | VDI 30             | EMCOTURN E65 SM/SMY   Maxxturn 65 SM   Hyperturn 65   Vertical VT 160   Maxxturn 65 M   Hyperturn*   EMCOTURN E65 M/MY, S65   EMCOTURN E45 M/MY, S45   EMCOTURN 345-II   Concept Turn 450   Maxxturn 65 SMY  |                   |
|                              | VDI 40             | Hyperturn 65/645/665   EMCOTURN E65 SM/SMY   Vertical VT 250/260/400   Maxxturn 65   Hyperturn 95/110   Hyperturn 690   EMCOTURN E65 M/MY  |                   |
| Force One                    | VDI 30             | FCL-450TM/S, 550TM/S, 580TM  |                   |
|                              | VDI 40             | FCL-580TMS   |                   |
| Gildemeister                 | VDI 25             | Sprint 50   Twin 32 / 42 / 65  |                   |
|                              | VDI 30             | CTX 320 linear V3   CTX 320 linear V5   Twin 102   Twin 42 / 65 Frame size 2   Sprint 65 linear   CTX 410 V6   CTX 410 V4   CTX 410 V3   CTX 400 E radial tooling turret   CTX 320 linear V6   CTX 320 linear V4   CTX 310 V6   CTX 310 V4   CTX 310 V3   CTX 310 ECOLINE   CTX 210 V3   | Da 4.13<br>a 4.23 |
|                              | VDI 40             | Sprint 65 linear   CTX 510   CTX 450 / 510 ECOLINE   CTX 520 linear   CTX 420 linear face tooling turret   GMX 500 linear   GMX 300 / 400 linear   GMX 250 linear   Twin 102   Twin 42 / 65 Frame size 2   CTX 420 linear radial tooling turret   CTX 520 linear with Y-axis   |                   |
|                              | VDI 50             | CTX 620 linear   CTX 650 ECOLINE   |                   |
| Hardinge                     | VDI 40             | GS 200, 250 MSY  |                   |
| Hurco                        | VDI 30             | TMM 8  |                   |
|                              | VDI 40             | TMX 8, TMX10 MY/MYS   TMM 10   |                   |
| Hyundai WIA                  | VDI 30             | L150 SY  |                   |
|                              | VDI 40             | SKT210SY   L200, 250Y/SY / SKT200, 250Y/SY   |                   |
| Jyoti                        | VDI 40             | TMX 200   TMC 350  |                   |
| Kovosvit Mas                 | VDI 30             | SP180 SMC, SY   SP180 MC, Y  |                   |
|                              | VDI 40             | SP280 SMC, SY   SP280 MC, Y  |                   |
| Monforts                     | VDI 40             | RNC 400, 500 with subspindle   DNC 500, MHC, MNC 500 (Turret 2)  |                   |
| Mylas                        | VDI 25             | DT42/52/65 sub turret  |                   |
|                              | VDI 30             | DT42/5/65 main turret (VDI)   GT42/52 main turret (VDI)   DY42/52/60 main turret (VDI)   |                   |
| Niles Simmons                | VDI 60             | N 40/50   N 30   |                   |
| Romi                         | VDI 40             | G 30M  |                   |
|                              | VDI 50             | G 50M  |                   |
| Sauter                       | VDI 20             | Axial VDI 20, DIN 5480, W10  |                   |
|                              | VDI 25             | Radial VDI 25, DIN 5480  |                   |
|                              | VDI 30             | Axial VDI 30, DIN 5480, right   Radial VDI 30, L2=100   Radial VDI 30, DIN 5480, LF=100   Radial VDI 30, DIN 5480, LF=85   |                   |
|                              | VDI 40             | Axial VDI 40, DIN 5480, right   Axial VDI 40, DIN 5480, left   Radial VDI 40, DIN 5480, LF=100   Radial VDI 40, DIN 5480, LF=120   |                   |
|                              | VDI 50             | Axial VDI 50, DIN 5480, right   Axial VDI 50, DIN 5480, left   Radial VDI 50, DIN 5480   |                   |

# COMPATIBILITÀ MOTORIZZATI

## DRIVEN TOOLS COMPATIBILITY

In fase d'ordine specificare: **CoSTRUTTORE, MODELLO & N° POSIZIONE TORRETTA**  
 In case of order please specify **MACHINE BUILDER, MODEL & TURRET N°**

| Costruttore<br>Builder Brand | Torretta<br>Turret | Modelli Macchina<br>Lathe or turret Models  | LP06<br>Pages     |
|------------------------------|--------------------|---|-------------------|
| Sauter                       | VDI 60             | Axial VDI 60, DIN 5480, right   Radial VDI 60, DIN 5480   |                   |
|                              | VDI 30             | VTurn-A16/20SCV, YCV, YSCV   VTurn-A16/20CV   VTurn II-16/20YCV   VTurn II-16/20CV                              | Da 4.13<br>a 4.23 |
| Victor                       | VDI 40             | VTurn-A26SCV, YCV, YSCV   VTurn-A26CV   VTurn II-23/26CV   VTurn II-23/26BCV, YCV                               |                   |
|                              | VDI 50             | VTurn-V760CV   VTurn-36/40/46CV   |                   |
| <b>DIN5482</b>               | <b>VDI</b>         | <b>VDI 20, 30, 40, 50</b>   |                   |
| Colchester                   | VDI 30             | Tornado T6M, 120M   |                   |
|                              | VDI 40             | Tornado T8M, 220M   |                   |
| Gildemeister                 | VDI 30             | CTX 400 E axial turret   CTX 310 eco  |                   |
|                              | VDI 40             | CTX 510 eco   |                   |
| Hyundai WIA                  | VDI 40             | L150, 210 LMA/LMSA / SKT15, 21LM  |                   |
| Monforts                     | VDI 40             | RNC 400, 500, 600 without subspindle   MNC 500 (Turret 1)   |                   |
|                              | VDI 50             | RNC 700, MNC 1000 (VDI50)   |                   |
|                              | VDI 60             | RNC 700, MNC 1000 (VDI60)   | Da 4.25<br>a 4.30 |
| Sauter                       | VDI 30             | Axial VDI 30, DIN 5482, left   Axial VDI 30, DIN 5482, right  |                   |
|                              | VDI 40             | Axial VDI 40, DIN 5482, right   Axial VDI 40, DIN 5482, left  |                   |
|                              | VDI 50             | Axial VDI 50, DIN 5482, right   Axial VDI 50, DIN 5482, left  |                   |
|                              | VDI 60             | Axial VDI 60, DIN 5482, right   Axial VDI 60, DIN 5482, left  |                   |
| Spinner                      | VDI 30             | TC 52, 65 MC (Sauter turret)  |                   |
| Traub                        | VDI 30             | TNA 300   |                   |
|                              | VDI 40             | TNA 400   |                   |
| Victor                       | VDI 40             | VTurn-V560CV  |                   |
|                              | VDI 50             | VTurn-36CV  |                   |
| <b>BARUFFALDI</b>            | <b>VDI</b>         | <b>VDI 20, 30, 40, 50, 60</b>   |                   |
| Baruffaldi                   | VDI 20             | VDI 20, TBMA/TBYA 100/120, right  |                   |
|                              | VDI 30             | VDI 30, TBMR/TBYR 160/200, left   VDI 30, TBMA/TBYA 120/160, right  |                   |
|                              | VDI 40             | VDI 40, TBMR/TBYR 200/250, left   VDI 40, TBMA/TBYA 160/200, right  |                   |
|                              | VDI 50             | VDI 50, TBMR/TBYR 250, left   VDI 50, TBMA/TBYA 200/250, right   VDI 50, TBMA/TBYA 200/250, left                |                   |
|                              | VDI 60             | VDI 60, TBMR/TBYR 320, right   VDI 60, TBMA/TBYA 250/320, right   VDI 60, TBMA/TBYA 250/320, left               |                   |
| Cmz                          | VDI 50             | TBI-520 A/B/C -MC   | Da 4.31<br>a 4.38 |
| Ecoca                        | VDI 20             | SJ-20MC   |                   |
| Johnford                     | VDI 30             | SL-20, 30, 35, 40/C   |                   |
|                              | VDI 40             | SL-50, 60, 65/C   |                   |
|                              | VDI 50             | ST-40, 60, 70, 80 A/B/C   ST-100, 130, 160, 200, 240 A/B   SL-70, 80, 100, 120 /C   HT-40, 60, 80 /C (2/4 Axis) |                   |
|                              | VDI 60             | ST-100, 130, 160, 200, 240 C/D  |                   |
| Spinner                      | VDI 30             | TC 600 axial turret VDI30   TC 600 SMCY (Baruffaldi turret)   TC 600 MCY   TC 600 MC VDI30   TC 400             |                   |
|                              | VDI 40             | TC 800 MCY   TC 800 MC   TC 600 MC  |                   |
|                              | VDI 50             | TC 77, 110 SMC   TC 77, 110 MCY   TC 800 MCY   TC 77, 110 MC   TC 800 SMC                                       |                   |
| <b>DIN1809</b>               | <b>VDI</b>         | <b>VDI 20, 25, 30, 40, 50, 60</b>   |                   |
| Biglia                       | VDI 30             | B42   |                   |
| Doosan                       | VDI 40             | Puma S400 M   | Da 4.39<br>a 4.46 |
| Emag                         | VDI 40             | VSC 200, 250   VLC 250   VL 2, 3, 4, 5, 6, 7  |                   |
|                              | VDI 50             | VSC 315, 400, 500, 7, VL 7, 8   |                   |
| Emco                         | VDI 20             | ET 342 TCM - DIN1809 version  |                   |
|                              | VDI 30             | EMCOMAT E300  |                   |

# COMPATIBILITÀ MOTORIZZATI

## DRIVEN TOOLS COMPATIBILITY

In fase d'ordine specificare: **CoSTRUTTORE, MODELLO & N° POSIZIONE TORRETTA**  
 In case of order please specify **MACHINE BUILDER, MODEL & TURRET N°**

| Costruttore<br>Builder Brand | Torretta<br>Turret | Modelli Macchina<br>Lathe or turret Models   | LP06<br>Pages     |
|------------------------------|--------------------|--|-------------------|
| Emco                         | VDI 50             | EMCOTURN 700 MC   EMCOTURN 800 MC  |                   |
|                              | VDI 60             | EMCOTURN 900 MC   Maxxturn 200 (VDI60)   |                   |
| Gildemeister                 | VDI 20             | CTX 200 - DIN1809 version  |                   |
| Hardinge                     | VDI 40             | GS 200, 250 MSY  |                   |
|                              | VDI 30             | TMM 8i   |                   |
| Hurco                        | VDI 40             | TMM 10i   TMX 8, TMX10 MY/MYS  |                   |
|                              | VDI 50             | TMM 12i  |                   |
| Hwacheon                     | VDI 40             | Cutex 240 SMC  |                   |
| Hyundai WIA                  | VDI 40             | L280LM / SKT28LM   |                   |
| Jyoti                        | VDI 30             | AX 200   ATM 160   |                   |
|                              | VDI 40             | AX 300   |                   |
| Kovosvit Mas                 | VDI 50             | MAS SP430, KL435 MC/Y   SP430 MC, Y  | Da 4.39<br>a 4.46 |
| Leadwell                     | VDI 30             | T-6M   |                   |
|                              | VDI 40             | T-8M   |                   |
| Romi                         | VDI 30             | GL 240/250M  |                   |
|                              | VDI 40             | GL 280/300M  |                   |
| Schaublin                    | VDI 20             | 125 CCN R-TM   |                   |
|                              | VDI 30             | 180-CCN   140-CNC, 140-R-CNC   |                   |
| Takamaz                      | VDI 40             | XY-2000 PLUS   |                   |
| Takisawa                     | VDI 40             | TY-2000   TS-3000, 4000, 5000 T15   TNR-200, 250   TMM-200, 250  |                   |
| Victor                       | VDI 30             | VTurn II-16/20CV   |                   |
|                              | VDI 40             | VTurn II-23/26CV   |                   |
| Ycm                          | VDI 30             | GT 200 MA (VDI turret)   |                   |
| <b>BIGLIA</b>                | <b>BMT</b>         | <b>BMT31, 40, 55</b>   |                   |
| Biglia                       | BMT31              | B1000-B1000M   | Da 5.25<br>a 5.30 |
|                              | BMT40              | BMX 45 Y2   B436, B438   |                   |
|                              | BMT55              | B750, B1250 (12 station turret)   Quattro B445, B470   BV210, BV315   B750, B1250 (16 station turret)   B620   B301, B501, B650, B658, B1200   B446 T2, B465 T2   B446 T3, B465 T3, B545, B565, B745, B765 |                   |
| <b>DOOSAN</b>                | <b>BMT</b>         | <b>BMT45, 55, 65, 75, 85</b>   |                   |
| Dn Solutions                 | BMT45              | Puma MX1600 ST   Lynx 2100 M/MS/LY/LSY   Puma TT1300 SY/SYY  | Da 5.34<br>a 5.35 |
| Doosan                       |                    | Lynx 220 LMS/LY/LSY   Puma TT1300 SY/SYY   Puma MX1600 ST   Lynx 220 M/LM   Lynx 2100 M/MS/LY/LSY  |                   |
| Emco                         |                    | Maxxturn 65 SMY   Hyperturn 45/50  |                   |
| Haas                         |                    | ST-10/15Y  |                   |
| Hanwha                       |                    | STL42 H/N/NH(Y3)   STL32/35/38H(Y3)  |                   |
| Hardinge                     |                    | TA-42,51 (BMT45-16T)   H-51, TT-42/51 (12 station)   T-42,51 (BMT45-16T)   Conquest H51 (16 station)   H-51, TT-42,51 (BMT45-16T)   T-42,51 (BMT45-12T)  |                   |
| Hwacheon                     |                    | Hi-Tech 230 YSMC (20ST, BMT45)   Cutex 180 MC/SMC/YMC/YSMC (16 station)  |                   |
| Hyundai WIA                  |                    | SE2200M/MS/LSY   |                   |
| Jyoti                        |                    | TMC 250, 350   AX 200  |                   |
| Mylas                        |                    | DT42/52/65 main turret   GT42/52 main turret   DY42/52/60 main turret  |                   |
| Nexturn                      |                    | NST56/67   |                   |
| Romi                         |                    | GL 250Y/S  |                   |
| Samsung (Smec)               |                    | NS 2100 SY   NS 2000M/LM, PL 1600, 2000M   |                   |
| Spinner                      |                    | TC 600 SMCY   TC 300, TTC 300 SMMCY  |                   |
| Takamaz                      |                    | XYT-51   |                   |

**5**

# COMPATIBILITÀ MOTORIZZATI

## DRIVEN TOOLS COMPATIBILITY

In fase d'ordine specificare: **CoSTRUTTORE, MODELLO & N° POSIZIONE TORRETTA**  
 In case of order please specify **MACHINE BUILDER, MODEL & TURRET N°**

| Costruttore<br>Builder Brand | Torretta<br>Turret | Modelli Macchina<br>Lathe or turret Models   | LP06<br>Pages     |
|------------------------------|--------------------|--|-------------------|
| Takisawa Taiwan              |                    | FX-1500  |                   |
| Tornos                       | BMT45              | SwissDECO 36 TB  | Da 5.34<br>a 5.35 |
| Victor                       |                    | VTurn-NP16CM   |                   |
| Accuway                      |                    | UT-100, 200 Y  |                   |
| Alex-Tech                    |                    | VT-27G, 30-33BLMC  |                   |
| Dn Solutions                 |                    | Puma TW2600 M   Puma TT1800, 2100 MS/SY/SYY   Puma SMX2100 ST   Puma MX1600, 2100 ST   Puma TL2000, 2500 M   Puma DNT 2100, 2600   Puma 2100,2600(II) M/MS/Y/SY   Puma 2100, 2600 Y/SY (16ST, BMT55)   Lynx 300 M,2600 Y, Puma GT2100,2600 M   Lynx 2600 Y/SY (16ST)   Lynx 2600 SY (12ST)   |                   |
| Doosan                       |                    | Puma SMX2100 ST   Puma 2100,2600 Y/SY, Lynx 2600 Y/SY (16ST, BMT55)   Lynx 2600 Y/SY (16ST)   Lynx 2600 SY (12ST)   Puma TW2600 M   Puma TT1500, 1800 MS/SY   Puma TL2000, 2500 M   Puma MX1600, 2100 ST   Puma 230, 240, 280 M/MS/LM   Puma 2100,2600(II) M/MS/Y/SY   Puma 2100, 2600 Y/SY (16ST, BMT55)   Puma 1500,2000,2500 M/MS/Y/SY   Lynx 300 M, 2600Y, Puma GT2100, 2600 M |                   |
| Emag                         |                    | VT 2, VTC 100-4, VL 2 P (BMT55-83)   VL 4-V3 (BMT55-100 turret size 360)   VL 4-V2 (BMT55-83 turret size 330)   VL 3, 5 Duo (BMT55-100)   VL 2, VLC 100 (BMT55-83)   VL 2, 4 (BMT 55 High Performance)   |                   |
| Emco                         |                    | Maxxturn 95 (BMT55-83)   Maxxturn 65 M/MY/SM/SMY (BMT55-83)   Hyperturn 65 (BMT55-83)  |                   |
| Goodway                      | BMT55              | GTX/GTZ-2000, 2600 M/Y (16 station)  | Da 5.36<br>a 5.37 |
| Hardinge                     |                    | TA-42,51 (BMT55-12T)   H-51   T-51/65   Conquest H51 (12 station)  |                   |
| Hwacheon                     |                    | VT 450 MC   Cutex 160, 180 MC/SMC/YMC/YSMC   |                   |
| Hyundai WIA                  |                    | SE2600M   SKT160, 180TTMS/TTSY   LM1600, 1800, 2200 TTMS/TTSY   L160, 230MA/LMA/LMSA   HD2200, 2600M/Y/SY  |                   |
| Jyoti                        |                    | AX 300   |                   |
| Leadwell                     |                    | T-7i M/SM  |                   |
| Mazak                        |                    | QT-Ez 8, 10, 12 M/MY/MSY   |                   |
| Romi                         |                    | GL 300Y/S  |                   |
| Samsung (Smec)               |                    | NS 2600 SY   NS 1600 T2Y2   SL 1500, 2000M/SY   PL 250V/VM   PL 240LM  |                   |
| Smart                        |                    | NL 2000 M/BM/SY/BSY  |                   |
| Takamaz                      |                    | XYT-51, 65   XT-8MY  |                   |
| Takisawa Taiwan              |                    | UX-2000  |                   |
| Tongtai                      |                    | TD-2000, 2500Y   |                   |
| Victor                       |                    | VTurn-A260YCM, YSCM (16ST, BMT55)   VTurn-Q200   VTurn-NP20CM, S20CM   VTurn-A16/20CM/200CM, SCM, YCM, YSCM  |                   |
| Ycm                          |                    | NTC-1600, 2000 M/LM/LS/Y/LY/LSY  |                   |
| Accuway                      |                    | UZ-2000 T2Y   UT-300 Y   |                   |
| Dn Solutions                 |                    | Puma V400 M   Puma DNT 2100, 2600   Puma TT2500 MS/SY   Puma MX2600 T/ST   Puma SMX2600, 3100 ST   Puma GT3100 M   Puma 3100 M/Y/SY   Puma 2100,2600(II) M/MS/Y/SY   |                   |
| Doosan                       |                    | Puma GT3100 M   Puma VT450 M, VT450 M-2SP   Puma V400 M   Puma V400   Puma TT2000, 2500 MS/SY   Puma SMX2600, 3100 ST   Puma MX2000, 2500, 2600 T/ST/SY   Puma Invertturn 3000 M   Puma 3100 M/Y/MY   Puma 300 M/MS   Puma 2100,2600(II) M/MS/Y/SY   |                   |
| Ecoca                        | BMT65              | MT-3/MT-4 MC/MCSY  | Da 5.38<br>a 5.39 |
| Emag                         |                    | VM 9, VMC 450 (BMT65-110)   VL 6 (BMT65-95 High Performance)   VL 6 (BMT65-110)  |                   |
| Emco                         |                    | Maxxturn 110   Hyperturn 100 Powermill   Hyperturn 95/110 SMB/SM2Y   |                   |
| Focus                        |                    | CNC FBL-300MC  |                   |
| Goodway                      |                    | GLS-2800, 3000, 3300 M/Y/MS/YS   GTH-2000, 2600 M   GTX/GTZ-2000, 2600 M/Y (12 station)   GS-2000 - 3300 M/Y/MS/YS (16 station)   GMT-2000   GMS-2000 ST (15 station)   GLS 2800-3300 M/Y/MS/YS  |                   |
| Haas                         |                    | ST-20/25/28/30/35, DS-30   DS-30 (BMT65 turret)  |                   |
| Hardinge                     |                    | GS-65   Elite 65 M Ultra   |                   |
| Hurco                        |                    | TMX 8, TMX10 MY/MYS  |                   |

# COMPATIBILITÀ MOTORIZZATI

## DRIVEN TOOLS COMPATIBILITY

In fase d'ordine specificare: **COSTRUTTORE, MODELLO & N° POSIZIONE TORRETTA**  
 In case of order please specify **MACHINE BUILDER, MODEL & TURRET N°**

| Costruttore<br>Builder Brand | Torretta<br>Turret | Modelli Macchina<br>Lathe or turret Models  | LP06<br>Pages     |
|------------------------------|--------------------|---|-------------------|
| Hwacheon                     |                    | VT 450 MC   Hi-Tech 230 SMC/YSMC   T2 MC/SMC/YMC/YSMC   Hi-Tech 350, 450 MC/SMC/YMC/YSMC   Hi-Tech 230 MC/YMC   Hi-Tech 200 MC   Cutex 240 MC/SMC   |                   |
| Hyundai WIA                  |                    | HD2600, 3100M/Y/YA/SY/SYA   HD2600, 3100M/Y/SY   WIA SKT250, 300M/MS   SKT200, 250TTM/MS/SY   LV450RM/LM   LM2000, 2500TTM/TTMS/TTSY   L300MA/MC/LMA/LMC/MSA/MSC/LMSA   L2100Y/SY   L2000, 2600, 3000Y/LY/SY/LSY  |                   |
| Johnford                     |                    | SL-60, 65   |                   |
| Jyoti                        |                    | TMC 500-2000 C  |                   |
| Leadwell                     |                    | LTC-25iM  |                   |
| Romi                         | BMT65              | GL 350M/Y/S   | Da 5.38<br>a 5.39 |
| Samsung (Smec)               |                    | SL 2000 T2Y2   SLV 500M   SL 2500Y/SY, PL 2000, 2500Y/SY   SL 3500 M/Y, PL 20-35M, 2000-2500MS  |                   |
| Smart                        |                    | NL 3500 Y   NL 3500 SY/BSY   NL 2500, 3000 M/BM/Y/SY  |                   |
| Spinner                      |                    | TTS 85, 125   TC 800 SMCY   |                   |
| Takisawa Taiwan              |                    | NX-2500 T15   NX-2500 T12   LX-2500, 3000M/Y   NEX-110Y   |                   |
| Tongtai                      |                    | TMT 2000 (BMT65, turret 1, 3)   TCS-1500, 2000, 2500   TMT 2000   TD-2000, 2500Y   TNL-120T   |                   |
| Victor                       |                    | VTurn-A26/260SCM, YSCM (12ST, BMT65)   VTurn-S26CM   VTurn-A26SCM, YSCM   |                   |
| Wele                         |                    | HL-200YS  |                   |
| Dn Solutions                 |                    | Puma V8300 M (ATC)   Puma V8300 M   Puma 4100, 5100 M/LM/LY   |                   |
| Doosan                       |                    | Puma V550, 8300 M (ATC)   Puma VT750 M, M-2SP   Puma V550, 8300 M   Puma 4100, 5100 M/LM/LY   Puma 400, 480, 500 M/LM   |                   |
| Haas                         |                    | ST-40/45Y   |                   |
| Hwacheon                     |                    | Hi-Tech 650 MC/YMC   VT 550, 650 MC   Hi-Tech 700 MC   Hi-Tech 550 MC   |                   |
| Hyundai WIA                  | BMT75              | LV500, 8500RM/LM   LV500RM/LM   SKT400M/LMC   LV800RM/LM   SKT-V80RM/LM   L400,4000,5100M/LM/MC/LMC/LY  | Da 5.40<br>a 5.41 |
| Romi                         |                    | GL 450M/Y   |                   |
| Samsung (Smec)               |                    | SL 4000, 4500, 5500M, SL4500LY   PL 45M/LY   SLV 800M, PL 800VM   |                   |
| Smart                        |                    | NL 4000, 5000 M/LM/LY   |                   |
| Takisawa Taiwan              |                    | LA-350,450 M/Y  |                   |
| Victor                       |                    | VTurn-V760CM   VTurn-S36CM   VTurn-40/45 CM, YCM  |                   |
| Baruffaldi                   |                    | TBMR/TBYR 320   |                   |
| Dn Solutions                 |                    | Puma VT1100 M   Puma VT900 M, V9300 M   Puma 600, 700, 800 M/LM/LY  |                   |
| Doosan                       |                    | Puma VT900 M, M-2SP, V9300 M   Puma VT1100 M   Puma 600, 700, 800 M/LM/LY   |                   |
| Emco                         |                    | Maxxturm 200  |                   |
| Focus                        |                    | FBL-510, 520, 530, 540MC  |                   |
| Hwacheon                     | BMT85              | Hi-Tech 750 MC/YMC   VT 950 MC   VT 1150 MC   Hi-Tech 850 MC/YMC  | 5.42              |
| Hyundai WIA                  |                    | KL7000, 8000LY   SKT600, 700LM   LV1100RM   L600, 700, 800MA/LMA  |                   |
| Samsung (Smec)               |                    | SL 65, 6500, 8500M   SLV 1000M   PL 60, 70, 80 M  |                   |
| Smart                        |                    | NL 6000, 7000 LM/XLM  |                   |
| Victor                       |                    | VTurn-V1000 (CM)  |                   |
| Ycm                          |                    | TC-46 M   |                   |
| <b>DMG MORI</b>              |                    | <b>NL, NZ, SL / ZL / DL</b>   |                   |
| Dmg Mori                     | NL                 | NLX 2500 Gen.2 (BMT60)   NLX 4000   NZX 2500 (BMT60)   NTX 2000, 2500, 3000 Gen. 2 (BMT60)   NT 4200, 4250, 4300, 5400   NL/NLX 1500, 2000, 2500, 3000 (12 ST)  |                   |
| Takisawa                     |                    | TS-4000 II T12 (3 key turret)   TS-3000, 4000, 5000 T12 (3 key turret)  |                   |
| Accuway                      |                    | UT-2000 T2M (BMT40)   UT-200 Y/SY, UZ-2000 (BMT40)  | Da 5.43<br>a 5.53 |
| Dmg Mori                     | NZ                 | NL/NLX 1500, 2000, 2500 (20 ST)   NTX 500 (BMT40)   NZ Due, Tre, Quattro (BMT40)   NTX 500 (BMT42/64)   NZ Due, Tre, Quattro (BMT42/64)   DuraTurn 2050, 2550 MC   DIM 1500   NZX 6000   NZX 2500 (turret 2 = BMT40)   NZX 1500-2000 (16 station)   NTX 1000,2000,2500,3000 Gen.2 (BMT40)   NT/NTX 1000-3200 (BMT40)   NRX 2000 MC   NLX 6000, NZX 4000   CLX 450, ecoTurn 450 (BMT40)   ALC/ALX 1500, 2000, 2500 (BMT40) |                   |
| Takisawa                     |                    | TM-2000, 3000 T12 (2 key turret)   TS-2000-5000 T20 (3 key turret)  |                   |

# COMPATIBILITÀ MOTORIZZATI

## DRIVEN TOOLS COMPATIBILITY

In fase d'ordine specificare: **Costruttore, MODELLO & N° POSIZIONE TORRETTA**  
 In case of order please specify **MACHINE BUILDER, MODEL & TURRET N°**

| Costruttore<br>Builder Brand | Torretta<br>Turret | Modelli Macchina<br>Lathe or turret Models   | LP06<br>Pages     |
|------------------------------|--------------------|--|-------------------|
| Comz                         |                    | TBI 520 - TL 20/25 (M/TM/MS)   TC 15/20/25/30/35 (M/Y/MS/YS)   TA 15/20/25/30 (M/Y/MS/YS)   TD 15/20/25/30/35/45/55 (M/Y/MS/YS)   TL 20, 25A, 25B M/TM/MS  |                   |
| Dmg Mori                     | SL / ZL / DL       | SL, ZL 150, 153, 154 (MC / SMC / Y/SY)   DL 15, 150 (MC)   DL-200, 250 MC   CL 200/203 - SL20/25 - DL 200/250 (MC)   SL 200/203/204/250/253/254(MC,SMC)2500Y   ZL 200(MC) - ZL250(SMC)   | Da 5.43<br>a 5.53 |
| Goodway                      |                    | GS 200/230/260/280 (M/MS)   GA 2000/2600/2800/3000/3300/3600 (M)   |                   |
| <b>GOODWAY</b>               |                    | <b>G1, G3, G4</b>  |                   |
|                              | G1                 | GLS100-GTS150 M (Bevel Gear version)   GTS-150 M (Bevel Gear version)   GLS-150 M (Bevel Gear version)   GLA-1500 M  | Da 5.55<br>a 5.57 |
| Goodway                      | G3                 | GV-500, 780 M   GTS-200, 260 MMX/XY (new turret version)   GS-3000, 3300, 3600 alpha   |                   |
|                              | G4                 | GS-2000 - 4000 M/Y/MS/YS (12 station turret)   |                   |
| <b>HAAS</b>                  |                    | <b>HS1, HS2, HS3</b>   |                   |
|                              | HS1                | SL-20/30 (VDI turret)  |                   |
| Haas                         | HS2                | ST-20/25/30/35, DS-30 (24 st. hybrid turret)   ST-20/25/30/35 (12 station hybrid turret)   ST-10/15/20/25/30/35, DS-30 (VDI40)   ST-10/15 (12 station hybrid turret)   SL-40 (VDI turret)   SL-20/30, TL-15/25 (12 st. hybrid turret)   DS-30 (12 station hybrid turret)   | Da 5.59<br>a 5.63 |
|                              | HS3                | ST-40/45, ST-40/45 L (12 st. hybrid turret)   SL-40 (12 station hybrid turret)   |                   |
| <b>MAZAK</b>                 |                    | <b>MZ1, MZ2, MZ3, MQ1, MQ2</b>   |                   |
|                              | MZ1                | QT/QTN 200, 250 MS/MSY (16D, VDI40-MZ1)   Super Quadrex 200, 250 M (16D, VDI40-MZ1)   Super Quick Turn 200, 250 MS/MSY (16D, VDI40-MZ1)   Super Quick Turn 200, 250 M/MY (16D, VDI40-MZ1)   Super Quick Turn 100 MS/MSY   QTN 200,250 MS/MSY (16D, VDI40-MZ1)   QT/QTN 100 MS/MSY (VDI40-MZ1)   Super Quick Turn 100 M/MY   QT/QTN 200, 250 M/MY(16D, VDI40-MZ1)   QT/QTN 100 M/MY (VDI40-MZ1) | Da 5.65<br>a 5.74 |
| Mazak                        | MZ2                | IVS-200, 300 M   QT/QTN 200, 250 MS/MSY (VDI40-MZ2)   Super Quick Turn 200, 250 MS/MSY (VDI40-MZ2)   Super Quick Turn 200, 250 M/MY (VDI40-MZ2)   Super Quadrex 200, 250 M (VDI40-MZ2)   QT/QTN 200, 250 M/MY (VDI40-MZ2)  |                   |
|                              | MZ3                | QT/QTN 300, 350, 400, 450 MSY (VDI50-MZ3)   Super Quick Turn 300, 350, 400, 450 M/MY   Slant Turn Nexus 500, 550, 600 M   QT/QTN 300, 350, 400, 450 M/MY (VDI50-MZ3)   Megaturn Nexus 900 M   HQR 450 M  |                   |
|                              | MQ1                | Multiplex 6200Y (16D, VDI40-MQ1)   Multiplex 6100   HQR 200, 250 MSY/NEO (16D, VDI40-MQ1)   HQR 100, 150 MSY   |                   |
|                              | MQ2                | Integrex i-250, 350, 450H ST (VDI)   Multiplex 6200, 6200Y, 6250, W-200, W-200Y (12D, VDI40-MQ2)   HQR 200, 250 MSY/NEO  |                   |
| <b>MIYANO</b>                |                    | <b>Ø38, Ø45, Ø54</b>   |                   |
| Miyano                       | Ø38                | ANX 42 SYY   BNA 34, 42 S/C/DHY/MSY/GTY  |                   |
| Accuway                      |                    | UA-200 Y   |                   |
| Goodway                      |                    | GTW-1500   GTS-150 MMX/XY (new turret version)   GLS-1500, 2000 M/LY/LMS/LYS   GLS-150, 200 M/Y (DIN1809 version)  | Da 5.75<br>a 5.80 |
| Miyano                       | Ø45                | BNX 42,51 SY   BNJ 34,42,51 S/SY   BNE-34,51 S/SY/MSY, BNE-51,65 MYY   BND-51 C/S/SY   ABX 51, 64 SY/TH2/TH3   |                   |
| Smart                        |                    | SL 15, 26M   SL 15, 20, 280YS/LYS  |                   |
| Star                         |                    | SK51   |                   |
| Miyano                       | Ø54                | ABX 51,64,80 SYY/THY   |                   |
| <b>NAKAMURA</b>              |                    | <b>N44, N55, N65, N75</b>  |                   |
| Goodway                      |                    | GTZ-1500Y  |                   |
| Muratec                      | N44                | MT 100, 1051, 1065 (15-Station)  |                   |
| Nakamura                     |                    | MX-100   WT-100   Super NTMX, MX-5   SC-100   NTY <sup>3</sup> -100(V), WY-100 I/IV (12 ST)   NTJ-100  |                   |
| Accuway                      |                    | UA-330 LY   UA-1500 T2Y   UA-1500 T2Y2   |                   |
| Eurotech                     |                    | TD 15-55 M/MS/Y/YS (15 ST)   TTL / TX 52, 66   TA 15, 20, 25, 30 M/MS/Y/YS (15 ST)   | Da 5.81<br>a 5.86 |
| Muratec                      | N55                | MT 1065EX (12-Station)   |                   |
| Nakamura                     |                    | SC-200 II (12 ST)   JX-250   WTS-150, WTW-150   WT-250   WT-150, WT-150 II, WT-250 II   TW-10, TW-20 (16 ST)   Super NTM <sup>3</sup>   Super NTJX   Super NTJ   Super NTJ   SC-250   SC-150   NTY <sup>3</sup> -150(V), 250, WY-150(V), 250   AS-200 (15 ST)   AS-200 (12 ST)   |                   |
| Averex                       | N65                | MTX1-76 SY1, MTX2-76 SY2   |                   |
| Nakamura                     |                    | WT-300   TW-20 (12 ST)   Super NTX   SC-300 II   SC-300  |                   |
| Nakamura                     | N75                | TW-30   STW-40   STS-40   SC-450   |                   |

# COMPATIBILITÀ MOTORIZZATI

## DRIVEN TOOLS COMPATIBILITY

In fase d'ordine specificare: **CoSTRUTTORE, MODELLO & N° POSIZIONE TORRETTA**  
 In case of order please specify **MACHINE BUILDER, MODEL & TURRET N°**

| Costruttore<br>Builder Brand | Torretta<br>Turret | Modelli Macchina<br>Lathe or turret Models   | LP06<br>Pages       |
|------------------------------|--------------------|--|---------------------|
| <b>OKUMA</b>                 |                    | <b>K1, K2, K3, BMT55, BMT60</b>  |                     |
| Okuma                        | VDI30-K1           | LT 200 M, LT 200 MY   LB/LU 200, 2000 M (VDI30)   LB 200 MY   LB 10   GENOS L200, L2000-e M/MY (VDI30)   ES L8 M   ES L6 M   |                     |
|                              | VDI40-K2           | Captain L370 MW   LB 300 MW (Face tooling turret)   MacTurn350-2S   MacTurn250-2S   LB/LU 300, 3000 M (VDI40)   LVT 300 M   LT 300 M, LT 300 MY   LB/LU 300 MY   LB 300 MYW   LB 300 MW (Radial tooling turret)   LB 15   GENOS L300, L3000-e M/MY (VDI40)   GENOS L300 MW/MYW (VDI40)   ES L10 M   Captain L370 M | Da 5.87<br>a 5.93   |
|                              | VDI40-K3           | LVT 400 M   LB/LU 400,4000 M (VDI40)   LB 25   |                     |
|                              | BMT55              | LT 2000 EX M/MY (16 station turret)  |                     |
|                              | BMT60              | LB/LU 4000 EX (II) M/MY   2SP-2500H   LT 3000 EX M/MY   Multus U3000, 4000, 5000 2SW   LB/LU 2000-3000 EX (II, III) M/MY/MW/MYW   GENOS L300 MW/MYW, L3000-e M/MY/MYW  |                     |
| <b>SPINNER</b>               |                    | <b>BMT45SP, VDI 25SP, VDI30, VDI40, VDI50</b>  |                     |
| Spinner                      | BMT 45SP           | Microturn 36, 52   TTS 42, 65   TC 300 - 600(SMCY) - TTC 300 (SMCY)  |                     |
|                              | VDI 25SP           | TD 42, 65 - TC, TTC 300  | Da 5.95<br>a 5.98   |
| Baruffaldi                   | VDI30              | TC 400 - 600(MC, MCY, SMCY)  |                     |
|                              | VDI40              | TC 800 MCY/MC   TC 600(MC, MCY, SMCY)  |                     |
|                              | VDI50              | TC 77, 110, 800(MC, MCY, SMCY)   |                     |
| <b>TAKISAWA T.</b>           |                    | <b>BMT60</b>   |                     |
| Takisawa Taiwan              | BMT60              | EX-1500, 2000 YT/YS   EX-308/310/508/509/510/710/908/910   EX/NEX-508, 510, 908, 910   FX-800   LA-250 YS/YT T15   LA-250, 300 M/Y   LX-2500M/Y   MX-800   NEX-108, 110M/Y   VTL-450 M   | Da 5.99<br>a 5.101  |
| <b>TSUGAMI</b>               |                    | <b>TS65</b>  |                     |
| Tsugami                      | TS65               | M06, M08 D/SD/SY, M10D   | Da 5.103<br>a 5.108 |



**NUOVI MOTORIZZATI POTENZIATI DISPONIBILI !!**  
NEW UPGRADED DRIVEN TOOLS AVAILABLE !!

**SCARICA  
IL CAPITOLO  
DOWNLOAD  
THE CHAPTER !!**

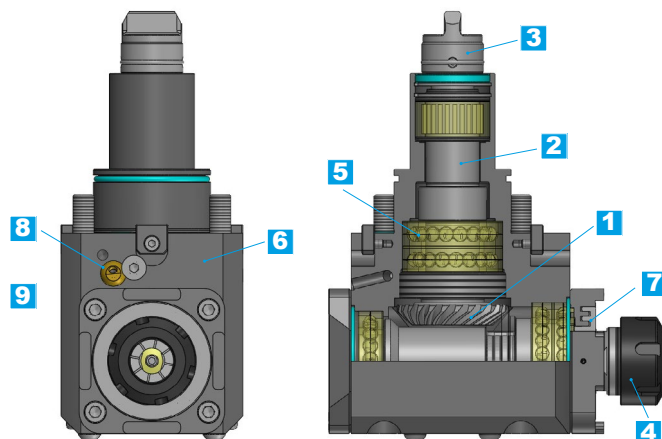
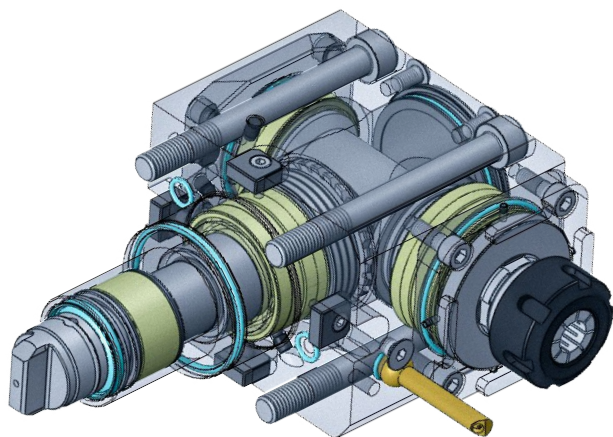

### 1 - INGRANAGGI GLEASON

Rettificati e progettati per ottimizzare la coppia in uscita e ridurre le sollecitazioni. Il moto viene trasmesso tramite due chiavette, garantendo affidabilità e precisione. La rettifica migliora la silenziosità di funzionamento grazie all'elevata accuratezza geometrica, mentre l'alta resistenza all'usura rende questi ingranaggi ideali per applicazioni ad alte prestazioni.

### 2 - ALBERI CEMENTATI

Gli alberi sono cementati e temprati, con successiva finitura di diametri e battute. La loro struttura è progettata per sopportare carichi elevati e sollecitazioni dinamiche ed è idonea al funzionamento in entrambi i sensi di rotazione. La geometria è studiata per garantire rigidità e stabilità anche in condizioni di lavoro gravose.

### 3 - TRASMISSIONE DEL MOTO

Il tenone maggiorato assicura una maggiore stabilità strutturale, riduce le vibrazioni e consente una distribuzione più uniforme delle sollecitazioni meccaniche, migliorando l'affidabilità complessiva del sistema.

### 4 - USCITA UTENSILE

L'albero mandrino è disponibile nelle versioni con pinza esterna o interna, oppure con alberi integrali Weldon, portafrese, HSK e altre configurazioni. Le ghiera ER garantiscono elevate prestazioni, assicurando precisione e affidabilità nel serraggio. Il sistema è inoltre predisposto per l'utilizzo del cambio rapido UNI-CHANGE.

### 5 - CUSCINETTI

I cuscinetti a sfere a contatto obliquo di alta qualità servono a garantire una rotazione fluida, precisa e ad alta velocità. L'accurata scelta dei componenti assicura prestazioni elevate e affidabilità nel lungo periodo.

### 6 - CORPO MONOBLOCCO

Realizzato in acciaio e ottimizzato per la refrigerazione interna ed esterna. È progettato con geometrie e smussi che migliorano l'ergonomia, la maneggevolezza e l'estetica complessiva.

### 7 - SISTEMA DI PROTEZIONE MANDRINO

Il sistema di tenuta lato mandrino adotta una configurazione a labirinto, studiata per applicazioni ad alta velocità. Si tratta di una tenuta meccanica senza contatto, basata su una sequenza di gole e camere concentriche che creano un percorso controllato per il refrigerante. In caso di infiltrazioni, la forza centrifuga generata dalla rotazione spinge il liquido verso l'esterno, dove viene espulso tramite appositi fori di drenaggio prima di raggiungere i componenti interni. Questo sistema garantisce un'elevata protezione, riduce la necessità di manutenzione e contribuisce a mantenere stabile la temperatura anche durante cicli di lavoro intensivi.

### 8 - UGELLI REFRIGERANTE

Sono progettati per resistere ad alte pressioni e consentono l'installazione di un tappo, permettendo una gestione flessibile e personalizzata del flusso di refrigerante.

### 9 - CHIAVE MANDRINO

La chiave mandrino semplifica il cambio utensile: blocca il mandrino in modo sicuro e consente all'operatore di lavorare con entrambe le mani, migliorando ergonomia, sicurezza e rapidità di intervento.

### 1 - GLEASON GEARS

Precision-ground Gleason gears are designed to optimize torque output and reduce mechanical stresses. Power transmission is achieved via two keys, ensuring reliability and accuracy. The grinding process enhances quiet operation thanks to precise gear geometry, while the high wear resistance makes these gears ideal for high-performance applications.

### 2 - CASE HARDENED SHAFTS

The shafts are case-hardened and hardened, followed by precision finishing of diameters and shoulders. Their structure is engineered to withstand high loads and dynamic stresses and is suitable for operation in both directions of rotation. The geometry ensures rigidity and stability even under heavy-duty operating conditions.

### 3 - MOTION TRANSMISSION

The oversized tenon provides increased structural stability, reduced vibrations, and a more uniform distribution of mechanical stresses, improving overall system reliability.

### 4 - TOOL OUTPUT

The spindle shaft is available in external or internal collet versions, as well as with integral shanks such as Weldon, end mill holders, HSK, and other configurations. ER nuts ensure high performance, providing precise and reliable clamping. The system is also designed for compatibility with the UNI-CHANGE quick-change system.

### 5 - BEARINGS

High-quality angular contact ball bearings are used to ensure smooth, precise, and high-speed rotation. Careful component selection guarantees high performance and long-term reliability.

### 6 - ONE-PIECE BODY

The one-piece steel body is optimized for internal and external cooling and features geometries and chamfers designed to enhance ergonomics, handling, and overall aesthetics.

### 7 - SPINDLE PROTECTION SYSTEM

The spindle-side sealing system adopts a labyrinth configuration, specifically designed for high-speed applications. This non-contact mechanical seal consists of a sequence of grooves and concentric chambers that create a controlled path for the coolant. In the event of infiltration, the centrifugal force generated by rotation drives the liquid outward, where it is expelled through dedicated drainage holes before reaching internal components. This system ensures excellent protection, reduces maintenance requirements, and helps maintain stable operating temperatures even during intensive duty cycles.

### 8 - COOLANT NOZZLES

The coolant nozzles are designed to withstand high pressures and allow the installation of a plug, enabling flexible and customized coolant flow management.

### 9 - SPINDLE WRENCH

The spindle wrench simplifies tool changes by securely locking the spindle, allowing the operator to work with both hands free, improving safety, ergonomics, and efficiency.

## Stozzatore Motorizzato / Motorized Slotter

# STOZZATORE

### Stozzatore motorizzato modulare per torni e torrette

#### Motorized slotter for lathes and turrets

#### POTENZIA ED AGGIORNA IL TUO TORNIO UPGRADE YOUR CNC LATHE

Lo stozzatore motorizzato è stato realizzato per risolvere, nel modo più efficace, il problema di dover realizzare su tornio CNC determinate lavorazioni, che vanno dalla semplice sede per chiave a profili dentati interni o esterni.

È stato progettato per ottenere il massimo della rigidità possibile. Questa caratteristica consente un utilizzo molto prolungato dell'inserto e un ottimo grado di finitura della superficie lavorata.

L'utilizzo di questo stozzatore offre dei grandi vantaggi: oltre al fatto di essere estremamente rapido nell'eseguire la lavorazione, non richiede la movimentazione del pezzo su altre macchine, dove sarebbe necessario un ulteriore piazzamento.

Dispone di diverse registrazioni, utili per ottenere una corretta lavorazione, e può realizzare lavorazioni interne o esterne.

The motorized slotter has been designed to effectively solve the problem of machining certain parts on a CNC lathe, ranging from simple keyways to internal or external tooth profiles.

It has been designed to achieve maximum rigidity. This feature allows for prolonged use of the insert and an excellent finish on the machined surface.

The use of this motorized slotter offers great advantages: in addition to being extremely fast in performing the machining operation, it does not require the workpiece to be moved to other machines, where further positioning would be necessary.

It has several adjustments, useful for obtaining correct machining, and can perform internal or external machining operations.

Sono previsti fori per l'adduzione forzata di liquido refrigerante  
There are holes for the forced supply of coolant

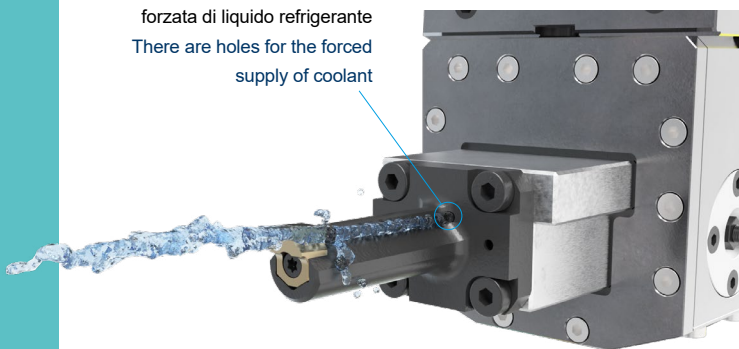

#### Vantaggi Operativi e di Efficienza Operational and Efficiency Advantages

- Lavorazione Diretta su CNC:** Permette di realizzare lavorazioni a taglio rettilineo, come sedi per chiave, prese di forza e profili dentati (interni o esterni).  
**Direct CNC machining:** Allows for straight cutting operations, such as keyways, power take-offs and toothed profiles (internal or external).
- Risparmio di Tempo e Costi:** È estremamente rapido nell'esecuzione. Non richiede la movimentazione del pezzo su macchine dedicate (stozzatrici o limatrici), eliminando la necessità di ulteriori piazzamenti e riducendo significativamente i tempi e i costi operativi.  
**Time and Cost Savings:** Extremely fast execution. Does not require the workpiece to be moved to dedicated machines (slotting machines or filing machines), eliminating the need for additional set-ups and significantly reducing operating times and costs.
- Massima Precisione:** Esegue le lavorazioni in tempi ridotti e con notevole precisione, garantendo un risultato perfettamente in tolleranza.  
**Maximum Precision:** Performs machining operations quickly and with remarkable precision, ensuring a result that is perfectly within tolerance.

#### Caratteristiche Tecniche e Qualità Technical Characteristics and Quality

- Rigidità Superiore:** Progettato per ottenere la massima rigidità. Questa caratteristica assicura una lavorazione perfettamente rettilinea all'asse del pezzo.  
**Superior Rigidity:** Designed for maximum rigidity. This feature ensures perfectly straight machining along the axis of the workpiece.
- Qualità di Finitura:** Garantisce un ottimo grado di finitura della superficie lavorata, grazie all'elevata rigidità.  
**Finish Quality:** Guarantees an excellent finish on the machined surface, thanks to its high rigidity.
- Durata Utensile:** L'eccezionale durata del tagliente dell'inserto è garantita dalla notevole rigidità del sistema.  
**Tool Life:** The exceptional life of the insert cutting edge is guaranteed by the remarkable rigidity of the system.
- Versatilità:** Può realizzare lavorazioni sia interne che esterne. Il corpo utensile è riutilizzabile e l'inserto è sostituibile.  
**Versatility:** Can perform both internal and external machining operations. The tool body is reusable and the insert is replaceable.
- Regolazioni:** Dispone di diverse registrazioni utili per ottenere una corretta lavorazione.  
**Adjustments:** Features several useful adjustments to ensure correct machining.

Lo stozzatore rappresenta un'efficace soluzione che permette di realizzare le lavorazioni di brocciatura e stozzatura direttamente sulla macchina utensile CNC (tornio, centro di lavoro, fresatrice, ecc.), senza dover attrezzare altre macchine o rivolgersi a terzi. In più, garantisce un risultato di ottima finitura e sempre perfettamente in tolleranza.

The motorized slotter is an effective solution that allows broaching and slotting operations to be carried out directly on the CNC machine tool (lathe, machining centre, milling machine, etc.), without having to set up other machines or outsource the work. It also guarantees an excellent finish and always perfectly within tolerance.

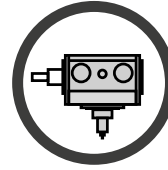

SCAN IT TO SEE



THE WEB PAGE



*Il rivoluzionario sistema di utensili!*

*The revolutionary tooling system!*



**REGOLAZIONE ANGOLARE**  
**ANGULAR ADJUSTMENT**

**Vite di registro angolo di taglio**  
**Cutting angle adjustment screw**

**Foro 3/8" gas**  
**adduzione interna**  
**3/8" internal gas**  
**supply hole**

**Perno registro asse Y**  
**Y-axis reference pin**

**Zona allineamento**  
**Alignment zone**

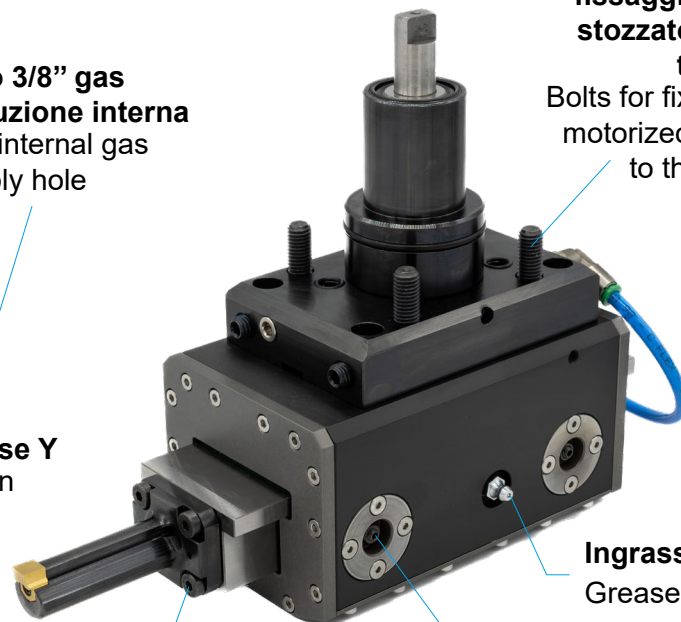

**Bulloni di fissaggio dello stozzatore alla torretta**  
**Bolts for fixing the motorized slotter to the turret**

**Ingrassatori**  
**Grease nipples**

**Vite di fissaggio utensile**  
**Tool fixing screws**

**REGOLAZIONE LONGITUDINALE**  
**LONGITUDINAL ADJUSTMENT**

**Sistema di registro giochi**  
**Clearance adjustment system**

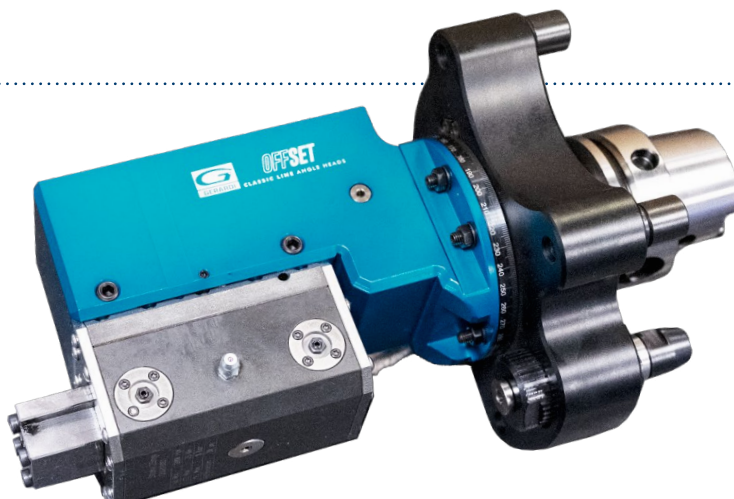

**DISPONIBILI ANCHE STOZZATORI MONTATI SU TESTE ANGOLARI**

**MOTORIZED SLOTTER MOUNTED ON ANGLE HEADS ALSO AVAILABLE**

**Contattaci per maggiori informazioni**  
**Please contact us for further information**

**HIGH PERF.**

SCARICA  
IL CAPITOLO  
DOWNLOAD  
THE CHAPTER !!



**NUOVI MOTORIZZATI POTENZIATI DISPONIBILI !!**  
**NEW UPGRADED DRIVEN TOOLS AVAILABLE !!**

# HIGH PERFORMANCE

**Elevata coppia e 12.000 Rpm per lavorazioni a secco!**

High torque and 12.000 Rpm for dry running!



## MASSIME PRESTAZIONI E PROGETTAZIONE OTTIMIZZATA

Maximum Performance and Optimised Design

- Progettazione ottimizzata nella struttura e nei cuscinetti
- Migliori performance in fresatura e foratura
- Albero principale esente da usura
- Optimized design in the structure and bearings
- Better performance in milling and drilling
- Wear-free main shaft



## EFFICIENZA TERMICA E MANUTENZIONE SEMPLIFICATA

Thermal efficiency and simplified maintenance

- Ridotto incremento delle temperature
- Tenuta meccanica senza guarnizione
- Montaggio smontaggio semplificati
- Intervalli di manutenzione ridotti
- Reduced increase in temperatures
- Mechanical seal without gasket
- Simplified assembly and disassembly
- Reduced maintenance intervals



## POSSIBILITÀ DI LAVORARE A SECCO

Dry running available

- Possibilità di lavorare a secco ad alte velocità (ma con valori ridotti del 70%)
- Continuo miglioramento della tecnologia di tenuta
- Possibility of dry running at high speeds (but with values reduced by 70%)
- Continuous improvement of sealing technology



## CHIAVE DI BLOCCAGGIO CON SISTEMA "SENZA MANI"

'Hands-free' locking wrench

- La chiave di bloccaggio dell'albero portapinzza rimane fissa liberando una mano per un migliore serraggio dell'utensile
- Ridotto il tempo operativo di attrezzaggio
- The collet holder shaft locking key remains fixed, freeing one hand for better tightening of the tool
- Reduced operating time when tooling up the machine.

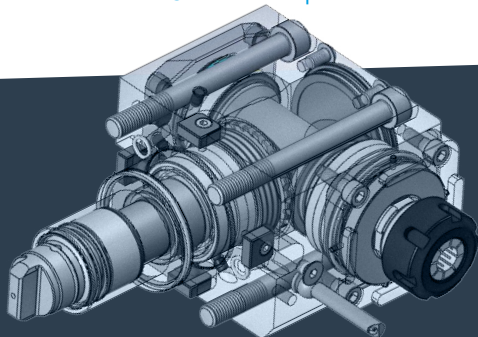

**Scansiona il QR Code per scaricare il capitolo e contatta il tuo Agente di zona!!**

Scan the QR Code to download the chapter and contact your local agent!



# Biglia



BMT 40 - BMT 55

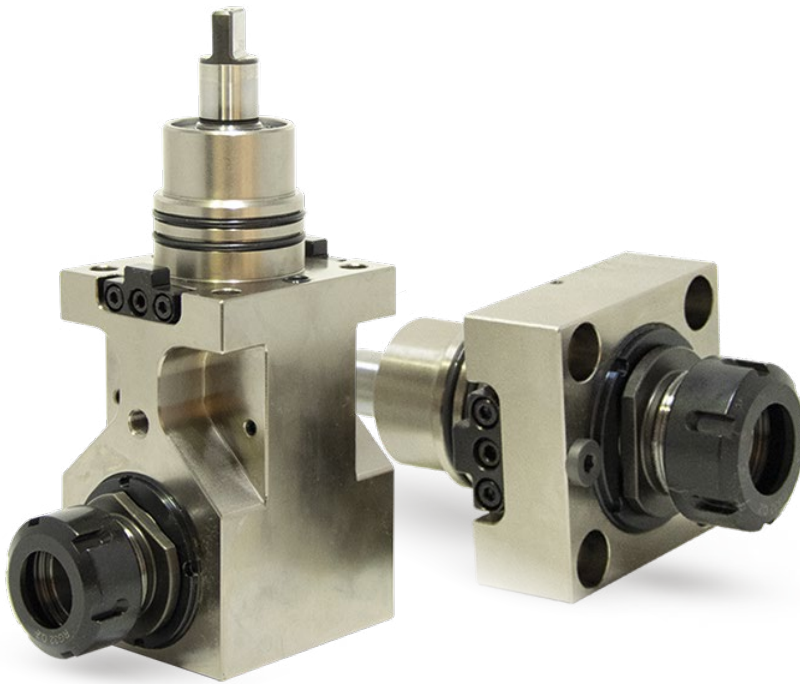

### DOTAZIONE STANDARD STANDARD EQUIPMENT



Chiave bloccaggio albero / chiave per bloccaggio ghiera / ugello refrigerazione / viti bloccaggio motorizzato

Shaft lock wrench / nut lock wrench cooling nozzle Art.183 / nozzle lock screws / driven tool locking screws

### CAMBI RAPIDI MODULARI MODULAR QUICK CHANGE



Facile e veloce sistema modulare per il cambio rapido delle diverse tipologie di portautensili con la sede per pinza ER (DIN6499).

Modular toolholder system for the fitting of toolholders in a spindle unit with ER collets (DIN6499) outputs.

**Il valore della coppia, espresso in Nm, è il massimo consentito. Per una maggiore durata, si consiglia di mantenerlo sotto tale soglia**  
The torque value, expressed in Nm, is the maximum allowed. For longer life, it is recommended to keep it below this limit

|              | c1  | c2 | d   | d1  | d2 | f   | f1 | f2 | f3 | h1   | h2 | h3 | t | t1 |
|--------------|-----|----|-----|-----|----|-----|----|----|----|------|----|----|---|----|
| <b>BMT40</b> | 12  | 4  | Ø40 | Ø35 | 15 | M8  | 50 | 50 | 14 | 58   | 43 | 20 | 7 | 10 |
| <b>BMT55</b> | Ø15 | 5  | Ø55 | Ø48 | -  | M10 | 63 | 65 | 12 | 94,5 | 53 | 28 | 8 | -  |

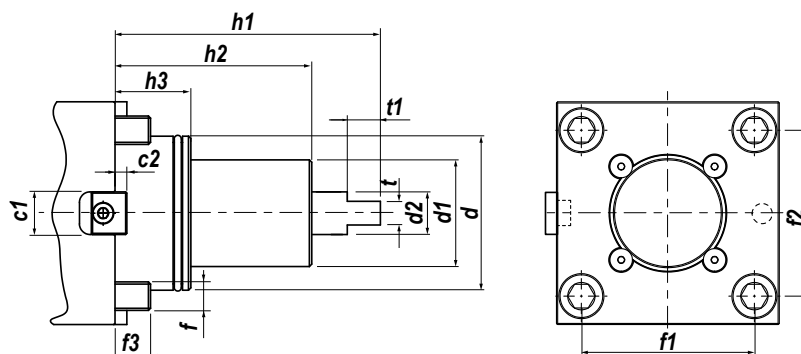

IN FASE D'ORDINE SPECIFICARE - IN CASE OF ORDER PLEASE SPECIFY:  
costruttore, modello e numero posizioni in torretta - machine builder, model and turret position numbers

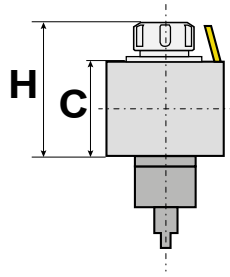
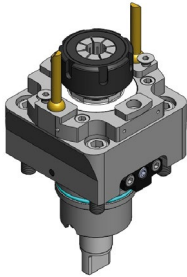
**ASSIALE - AXIAL**

L'asse dell'utensile è in linea all'asse della torretta o del mandrino

The tool axis is aligned to the turret or spindle axis

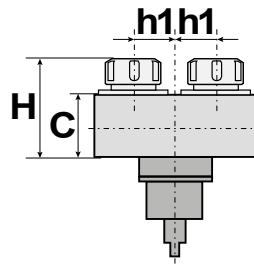
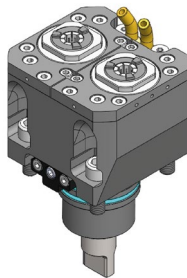
**ASSIALE 2 USCITE - AXIAL 2 OUTPUTS**

Un corpo unico ospita due uscite parallele orientate nella stessa direzione in linea con l'asse torretta

A single body contains two parallel outputs facing the same direction, aligned with the turret axis

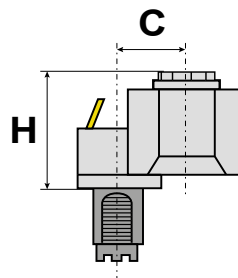
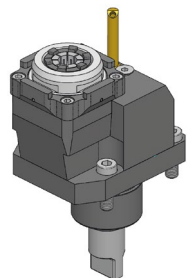
**ASSIALE DISASSATO - OFFSET AXIS**

L'asse dell'utensile è in linea ma traslato rispetto all'asse della torretta

The tool axis is aligned with, but offset from, the turret axis

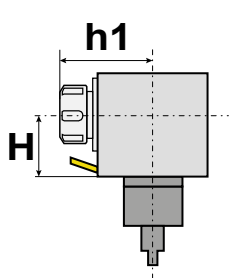
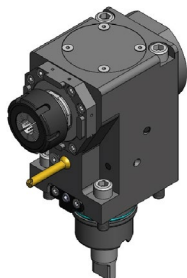
**RADIALE - RADIAL**

L'asse dell'utensile è perpendicolare all'asse della torretta o del mandrino

The tool axis is perpendicular to the turret or spindle axis

## RADIALE DOPPIO - DOUBLE RADIAL

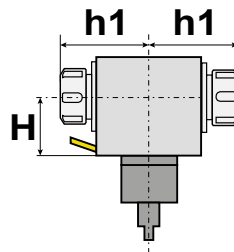
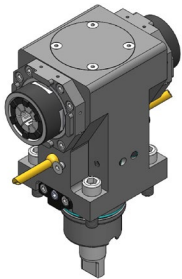

Il motorizzato ha due uscite situate sullo stesso asse radiale, ma rivolte in direzioni opposte

The driven tool has two outputs situated on the same radial axis, but facing in opposite directions

## RADIALE ARRETRATO - RADIAL REAR OFFSET

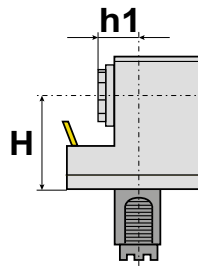
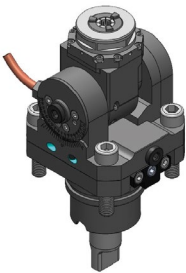

L'asse dell'utensile è perpendicolare all'asse della torretta o del mandrino ma traslato verso il corpo del motorizzato

The tool axis is perpendicular to the axis of the turret or spindle but offset towards the motorised unit

## PORTA CREATORE - DRIVEN GEAR HOBBER

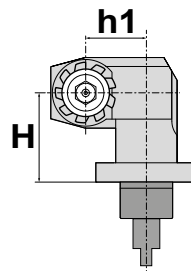
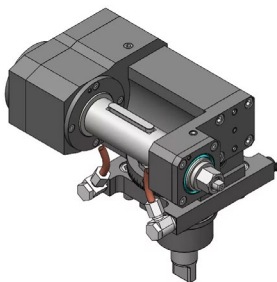

Dotato di una fresa specifica (creatore) su un albero rigido, montato su un supporto basculante

Equipped with a specific milling cutter on a rigid shaft, mounted on a pivoting support

MODELLI DI TORNIO COMPATIBILI  
 COMPATIBLE LATHE TYPES

Biglia

Vedi pagine compatibilità 5.14 / 5.20 - See compatibility pages 5.14 / 5.20

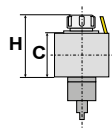

## ASSIALE AXIAL

SCAN IT TO SEE



THE TECHNICAL SHEETS

| Code      | Output      | Int Cool. | H     | C    | Nm | Ratio | Rpm    | Kg  | Sense of Rotation | Tech. Draw |
|-----------|-------------|-----------|-------|------|----|-------|--------|-----|-------------------|------------|
| 99.BG.A01 | ER-25 Ø1+16 | -         | 70    | 34,7 | 47 | 1 : 1 | 6.000  | 3.7 |                   |            |
| 99.BG.A43 | ER-25 Ø1+16 | -         | 70    | 34,7 | 47 | 1 : 1 | 6.000  | 3.7 |                   |            |
| 99.BG.A02 | ER-32 Ø2+20 | -         | 70    | 34,7 | 47 | 1 : 1 | 6.000  | 3.7 |                   |            |
| 99.BG.A03 | ER-32 Ø2+20 | • 18 bar  | 70    | 34,7 | 47 | 1 : 1 | 6.000  | 3.7 |                   |            |
| 99.BG.A04 | ER-32 Ø2+20 | • 18 bar  | 90    | 85,5 | 70 | 1 : 1 | 6.000  | 8   |                   |            |
| 99.BG.A46 | ER-32 Ø2+20 | -         | 90    | 85,5 | 70 | 1 : 1 | 6.000  | 8   |                   |            |
| 99.BG.A42 | ER-25 Ø1+16 | -         | 51    | 20   | 47 | 1 : 1 | 6.000  | 3.7 |                   |            |
| 99.BG.A45 | ER-16 Ø1+10 | -         | 70    | 20   | 4  | 1 : 4 | 24.000 | 3.7 |                   |            |
| 99.BG.A24 | PF-16 Ø16   | -         | 77.6  | 34,7 | 47 | 1 : 1 | 6.000  | 3.7 |                   |            |
| 99.BG.A25 | PF-16 Ø16   | -         | 67.6  | 34,7 | 47 | 1 : 1 | 6.000  | 3.7 |                   |            |
| 99.BG.A28 | PF-16 Ø16   | -         | 87.6  | 56,7 | 47 | 1 : 1 | 6.000  | 3.7 |                   |            |
| 99.BG.A19 | PF-22 Ø22   | -         | 89.6  | 56,7 | 47 | 1 : 1 | 6.000  | 3.7 |                   |            |
| 99.BG.A20 | PF-22 Ø22   | -         | 97.7  | 34,7 | 47 | 1 : 1 | 6.000  | 3.7 |                   |            |
| 99.BG.A22 | PF-22 Ø22   | -         | 104.6 | 56,7 | 47 | 1 : 1 | 6.000  | 3.7 |                   |            |
| 99.BG.A23 | PF-22 Ø22   | -         | 82.6  | 34,7 | 47 | 1 : 1 | 6.000  | 3.7 |                   |            |
| 99.BG.A21 | PF-27 Ø27   | -         | 99    | 51,2 | 70 | 1 : 1 | 6.000  | 8   |                   |            |
| 99.BG.A26 | PF-27 Ø27   | -         | 100.6 | 34,7 | 47 | 1 : 1 | 6.000  | 3.7 |                   |            |
| 99.BG.A27 | PF-27 Ø27   | -         | 103.6 | 56,7 | 47 | 1 : 1 | 6.000  | 3.7 |                   |            |

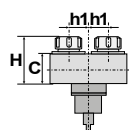

## ASSIALE 2 USCITE AXIAL 2 OUTPUTS

| Code      | Output      | Int Cool. | H | h1 | Nm | Ratio | Rpm    | Kg | Sense of Rotation | Tech. Draw |
|-----------|-------------|-----------|---|----|----|-------|--------|----|-------------------|------------|
| 99.BG.A41 | ER-16 Ø1+10 | -         |   |    |    | 1 : 2 | 12.000 |    |                   |            |

**ER** Portapinza  
Collet Holder

**PF** Portafresa  
Shell Mill Holder

 Ugualo al Mandrino  
Same as Spindle

 Opposto al Mandrino  
Opposite as Spindle

 Refrigerante Interno  
Internal Coolant

 Scarica il PDF  
PDF Download

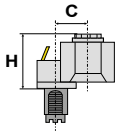

## ASSIALE DISASSATO AXIAL OFFSET

| Code      | Output      | Int Cool. | H   | C  | Nm | Ratio | Rpm    | Kg  | Sense of Rotation | Tech. Draw |
|-----------|-------------|-----------|-----|----|----|-------|--------|-----|-------------------|------------|
| 99.BG.A18 | ER-25 Ø1+16 | -         | 105 | 45 | 23 | 1 : 2 | 12.000 | 3.7 |                   |            |

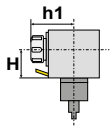

## RADIALE RADIAL

| Code      | Output      | Int Cool. | H   | h1   | Nm | Ratio | Rpm    | Kg  | Sense of Rotation | Tech. Draw |
|-----------|-------------|-----------|-----|------|----|-------|--------|-----|-------------------|------------|
| 99.BG.A12 | ER-16 Ø1+10 | -         | 70  | 79   | 4  | 1 : 4 | 24.000 | 3.7 |                   |            |
| 99.BG.A35 | ER-16 Ø1+10 | • 20 bar  | 100 | 79   | 4  | 1 : 4 | 24.000 | 3.7 |                   |            |
| 99.BG.A37 | ER-16 Ø1+10 | -         | 100 | 79   | 4  | 1 : 4 | 24.000 | 3.7 |                   |            |
| 99.BG.A08 | ER-25 Ø1+16 | -         | 100 | 50   | 47 | 1 : 1 | 6.000  | 3.7 |                   |            |
| 99.BG.A05 | ER-25 Ø1+16 | -         | 70  | 20   | 47 | 1 : 1 | 6.000  | 3.7 |                   |            |
| 99.BG.A06 | ER-32 Ø2+20 | -         | 70  |      | 47 | 1 : 1 | 6.000  | 3.7 |                   |            |
| 99.BG.A07 | ER-32 Ø2+20 | • 20 bar  | 70  |      | 47 | 1 : 1 | 6.000  | 3.7 |                   |            |
| 99.BG.A09 | ER-32 Ø2+20 | -         | 100 |      | 47 | 1 : 1 | 6.000  | 3.7 |                   |            |
| 99.BG.A10 | ER-32 Ø2+20 | • 20 bar  | 100 |      | 47 | 1 : 1 | 6.000  | 3.7 |                   |            |
| 99.BG.A11 | ER-25 Ø1+16 | -         | 70  | 98   | 23 | 1 : 2 | 12.000 | 3.7 |                   |            |
| 99.BG.A34 | ER-25 Ø1+16 | • 20 bar  | 70  | 98   | 23 | 1 : 2 | 12.000 | 3.7 |                   |            |
| 99.BG.A47 | ER-32 Ø2+20 | -         | 75  | 103  | 70 | 1 : 1 | 6.000  | 8   |                   |            |
| 99.BG.A49 | ER-32 Ø2+20 | • 20 bar  | 75  | 103  | 70 | 1 : 1 | 6.000  | 8   |                   |            |
| 99.BG.A39 | ER-25 Ø1+16 | -         | 40  | 84   | 40 | 1 : 1 | 6.000  | 6   |                   |            |
| 99.BG.A31 | ER-25 Ø1+16 | • 20 bar  | 100 | 84   | 40 | 1 : 1 | 6.000  | 6   |                   |            |
| 99.BG.A17 | PF-27 Ø27   | -         | 70  | 93,9 | 47 | 1 : 1 | 6.000  | 3.7 |                   |            |
| 99.BG.A36 | ER-25 Ø1+16 | -         | 70  |      | 23 | 2 : 1 | 12.000 | 3.7 |                   |            |
| 99.BG.A44 | ER-25 Ø1+16 | -         | 70  |      | 47 | 1 : 1 | 6.000  | 3.7 |                   |            |

MODELLI DI TORNIO COMPATIBILI  
 COMPATIBLE LATHE TYPES

Biglia

Vedi pagine compatibilità 5.14 / 5.20 - See compatibility pages 5.14 / 5.20

SCAN IT TO SEE



THE TECHNICAL SHEETS

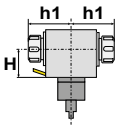

## RADIALE DOPPIO

### RADIAL DOUBLE

| Code      | Output                         | Int Cool. | H   | h1 | Nm | Ratio | Rpm   | Kg  | Sense of Rotation | Tech. Draw |
|-----------|--------------------------------|-----------|-----|----|----|-------|-------|-----|-------------------|------------|
| 99.BG.A13 | ER-25 / Ø1÷16 /<br>ER-16 Ø1÷10 | -         | 70  | 81 | 47 | 1 : 1 | 6.000 | 3.7 |                   | ↓          |
| 99.BG.A14 | ER-25 / Ø1÷16 /<br>ER-16 Ø1÷10 | -         | 100 |    | 47 | 1 : 1 | 6.000 | 3.7 |                   | ↓          |

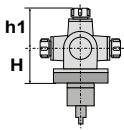

## ORIENTABILE

### ADJUSTABLE

| Code      | Output      | Int Cool. | H   | h1   | Nm | Ratio | Rpm    | Kg  | Sense of Rotation | Tech. Draw |
|-----------|-------------|-----------|-----|------|----|-------|--------|-----|-------------------|------------|
| 99.BG.A16 | ER-20 Ø1÷13 | -         | 100 | 98   | 23 | 1 : 1 | 12.000 | 3.7 |                   | ↓          |
| 99.BG.A15 | ER-16 Ø1÷10 | -         | 60  | 74,5 | 16 | 1 : 1 | 6.000  | 3.7 |                   | ↓          |
| 99.BG.A29 | ER-16 Ø1÷10 | -         | 60  | 74,5 | 8  | 1 : 2 | 12.000 | 3.7 |                   | ↓          |

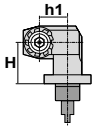

## PORTA CREATORE

### DRIVEN GEAR HOBBER

| Code      | Output | Int Cool. | H  | h1  | Nm | Ratio | Rpm   | Kg  | Sense of Rotation | Tech. Draw |
|-----------|--------|-----------|----|-----|----|-------|-------|-----|-------------------|------------|
| 99.BG.A40 | Ø16    | -         | 75 | 115 | 94 | 2 : 1 | 3.000 | 3.7 |                   | ↓          |

**ER** Portapinza  
 Collet Holder

**PF** Portafresa  
 Shell Mill Holder

 Uguale al Mandrino  
 Same as Spindle

 Opposto al Mandrino  
 Opposite as Spindle

 Refrigerante Interno  
 Internal Coolant

 Scarica il PDF  
 PDF Download

# BMT

## Bolt Mounted Turret

BMT 45 / 55 / 65 / 75 / 85



BMT



### USCITA C. ISO26623 C. ISO26623 OUTPUT

Disponibile su richiesta  
Available on request



### DOTAZIONE STANDARD STANDARD EQUIPMENT

Chiave bloccaggio albero / chiave  
per bloccaggio ghiera / ugello  
refrigerazione / viti bloccaggio  
motorizzato

Shaft lock wrench / nut lock wrench  
cooling nozzle Art.183 / nozzle lock  
screws / driven tool locking screws



### CAMBI RAPIDI MODULARI MODULAR QUICK CHANGE

Facile e veloce sistema modulare  
per il cambio rapido delle diverse  
tipologie di portautensili con la  
sede per pinza ER (DIN6499).

Modular toolholder system for the  
fitting of toolholders in a spindle unit  
with ER collets (DIN6499) outputs.

Il valore della coppia, espresso in Nm, è il massimo consentito. Per una maggiore durata, si consiglia di mantenerlo sotto tale soglia  
The torque value, expressed in Nm, is the maximum allowed. For longer life, it is recommended to keep it below this limit

| Type  | c1 | c2 | d  | d1 | d2   | f   | f1  | f2  | f3 | h1  | h2  | h3 | i1  | i2  | t  | t1  | h4  | N  | Ø M |
|-------|----|----|----|----|------|-----|-----|-----|----|-----|-----|----|-----|-----|----|-----|-----|----|-----|
| BMT45 | 15 | 4  | 45 | 35 | 14   | M8  | 58  | 58  | 10 | 84  | 60  | 40 | 75  | 75  | 6  | 8,5 | -   | -  | -   |
| BMT55 | 15 | 4  | 55 | 40 | 16   | M10 | 64  | 64  | 14 | 104 | 75  | 30 | 85  | 85  | 8  | 8,5 | 9,5 | 8  | 29  |
| BMT65 | 18 | 5  | 65 | 45 | 18   | M12 | 70  | 73  | 15 | 112 | 83  | 32 | 94  | 94  | 10 | 14  | 15  | 10 | 29  |
| BMT75 | 25 | 5  | 75 | 55 | 23   | M12 | 90  | 90  | 15 | 110 | 80  | 43 | 112 | 112 | 14 | 15  | -   | -  | -   |
| BMT85 | 25 | 5  | 85 | 65 | 33,5 | M12 | 100 | 100 | 18 | 140 | 100 | 43 | 125 | 125 | 16 | 20  | -   | -  | -   |

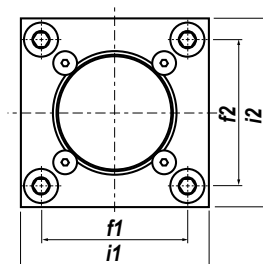
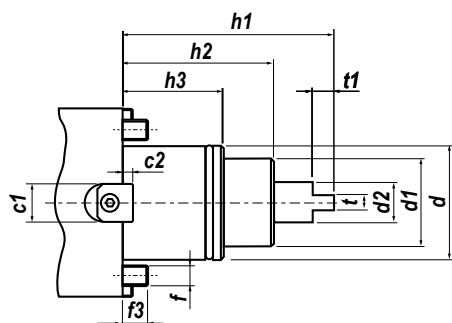

### TENONE MAGGIORATO BIGGER TENON

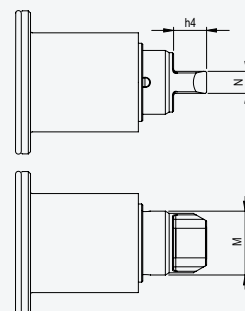

IN FASE D'ORDINE SPECIFICARE - IN CASE OF ORDER PLEASE SPECIFY:  
costruttore, modello e numero posizioni in torretta - machine builder, model and turret position numbers

## ASSIALE - AXIAL

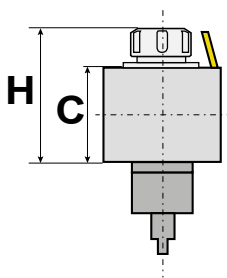
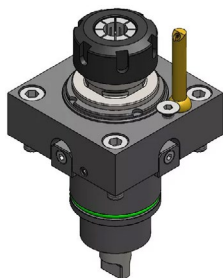

L'asse dell'utensile è in linea all'asse della torretta o del mandrino

The tool axis is aligned to the turret or spindle axis

**DISPONIBILE ANCHE CON TENONE MAGGIORATO**  
 ALSO AVAILABLE WITH BIGGER TENON

## ASSIALE DISASSATO - OFFSET AXIS

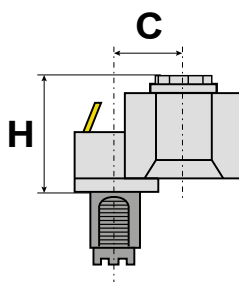
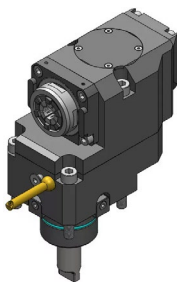

L'asse dell'utensile è in linea ma traslato rispetto all'asse della torretta

The tool axis is aligned with, but offset from, the turret axis

## ORIENTABILE - ADJUSTABLE

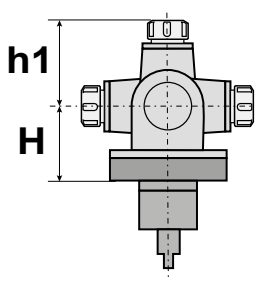
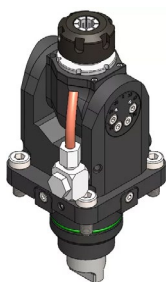

Permettono di inclinare l'asse dell'utensile secondo un angolo specifico richiesto dalla lavorazione

They allow the tool axis to be tilted to a specific angle required for the machining operation

**DISPONIBILE ANCHE CON TENONE MAGGIORATO**  
 ALSO AVAILABLE WITH BIGGER TENON

## RADIALE - RADIAL

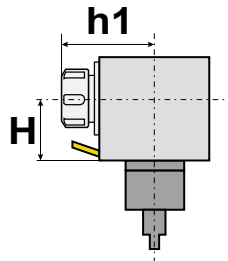

L'asse dell'utensile è perpendicolare all'asse della torretta o del mandrino

The tool axis is perpendicular to the turret or spindle axis

**DISPONIBILE ANCHE CON TENONE MAGGIORATO**  
 ALSO AVAILABLE WITH BIGGER TENON

## RADIALE DOPPIO - DOUBLE RADIAL

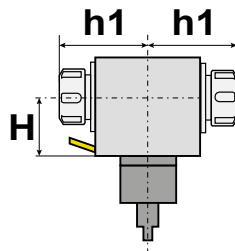
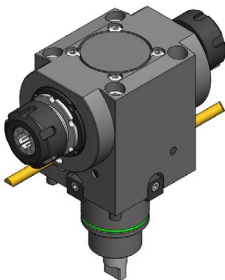

Il motorizzato ha due uscite situate sullo stesso asse radiale, ma rivolte in direzioni opposte

The driven tool has two outputs situated on the same radial axis, but facing in opposite directions

## RADIALE ARRETRATO - RADIAL REAR OFFSET

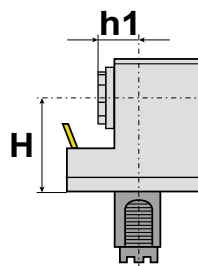
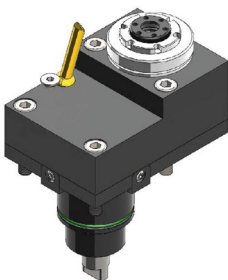

L'asse dell'utensile è perpendicolare all'asse della torretta o del mandrino ma traslato verso il corpo del motorizzato

The tool axis is perpendicular to the axis of the turret or spindle but offset towards the motorised unit

**DISPONIBILE ANCHE CON TENONE MAGGIORATO**  
 ALSO AVAILABLE WITH BIGGER TENON

MODELLI DI TORNIO COMPATIBILI  
 COMPATIBLE LATHE TYPES

 Dn Solutions | Doosan | Emco | Haas | Hanwha | Hardinge | Hwacheon | Hyundai WIA | Jyoti |  
 Mylas | Nexturn | Romi | Samsung | Spinner | Takamaz | Takisawa Taiwan | Tornos | Victor

Vedi pagine compatibilità 5.14 / 5.20 - See compatibility pages 5.14 / 5.20

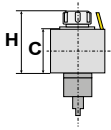

## ASSIALE AXIAL

SCAN IT TO SEE



THE TECHNICAL SHEETS

| Code      | Output      | Int Cool. | H    | C  | Nm | Ratio | Rpm    | Kg | Sense of Rotation | Tech. Draw |
|-----------|-------------|-----------|------|----|----|-------|--------|----|-------------------|------------|
| 99.DS.A03 | ER-25 Ø1÷16 | -         | 57.2 | 40 | 20 | 1 : 1 | 6.000  | 2  |                   | ↓          |
| 99.DS.A04 | ER-25 Ø1÷16 | • 80 bar  | 57.2 | 40 | 20 | 1 : 1 | 6.000  | 2  |                   | ↓          |
| 99.DS.A05 | ER-16 Ø1÷10 | -         | 86.5 | 57 | 12 | 1 : 4 | 32.000 | 45 |                   | ↓          |
| 99.DS.A83 | ER-32 Ø2÷20 | -         | 80.2 | 40 | 20 | 1 : 1 | 6.000  | 3  |                   | ↓          |
| 99.DS.A84 | ER-32 Ø2÷20 | • 80 bar  | 80.2 | 40 | 20 | 1 : 1 | 6.000  | 2  |                   | ↓          |

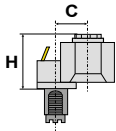

## ASSIALE DISASSATO AXIAL OFFSET

| Code      | Output      | Int Cool. | H    | C  | Nm | Ratio | Rpm    | Kg | Sense of Rotation | Tech. Draw |
|-----------|-------------|-----------|------|----|----|-------|--------|----|-------------------|------------|
| 99.DS.A06 | ER-16 Ø1÷10 | -         | 70.5 | 45 | 15 | 1 : 2 | 16.000 | 4  |                   | ↓          |

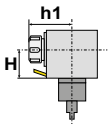

## RADIALE RADIAL

| Code       | Output      | Int Cool. | H  | h1   | Nm | Ratio | Rpm    | Kg | Sense of Rotation | Tech. Draw |
|------------|-------------|-----------|----|------|----|-------|--------|----|-------------------|------------|
| 99.DS.A07  | ER-25 Ø1÷16 | -         | 65 | 84,9 | 20 | 1 : 1 | 6.000  | 5  |                   | ↓          |
| 99.DS.A07C | ER-25 Ø1÷16 | -         | 65 | 84,9 | 20 | 1 : 1 | 6.000  | 5  |                   | ↓          |
| 99.DS.A08  | ER-25 Ø1÷16 | • 80 bar  | 65 | 84,9 | 20 | 1 : 1 | 6.000  | 5  |                   | ↓          |
| 99.DS.A08C | ER-25 Ø1÷16 | • 80 bar  | 65 | 84,9 | 20 | 1 : 1 | 6.000  | 5  |                   | ↓          |
| 99.DS.A97  | ER-25 Ø1÷16 | -         | 85 | 84,9 | 20 | 1 : 1 | 6.000  | 6  |                   | ↓          |
| 99.DS.A97C | ER-25 Ø1÷16 | -         | 85 | 84,9 | 35 | 1 : 1 | 8.000  | 6  |                   | ↓          |
| 99.DS.A67  | ER-25 Ø1÷16 | • 80 bar  | 85 | 84,9 | 20 | 1 : 1 | 6.000  | 6  |                   | ↓          |
| 99.DS.A09  | ER-16 Ø1÷10 | -         | 65 | 69,7 | 12 | 1 : 4 | 32.000 | 5  |                   | ↓          |
| 99.DS.A10  | ER-16 Ø1÷10 | -         | 65 | 73,3 | 15 | 1 : 2 | 16.000 | 5  |                   | ↓          |
| 99.DS.A87  | ER-32 Ø2÷20 | -         | 65 | 93,6 | 35 | 1 : 1 | 8.000  | 6  |                   | ↓          |
| 99.DS.A87C | ER-32 Ø2÷20 | -         | 65 | 93,6 | 35 | 1 : 1 | 8.000  | 6  |                   | ↓          |
| 99.DS.A88  | ER-32 Ø2÷20 | • 80 bar  | 65 | 93,6 | 35 | 1 : 1 | 8.000  | 6  |                   | ↓          |

**ER** Portapinza  
Collet Holder

**PF** Portafresa  
Shell Mill Holder

 Ugualo al Mandrino  
Same as Spindle

 Opposto al Mandrino  
Opposite as Spindle

 Refrigerante Interno  
Internal Coolant

 Scarica il PDF  
PDF Download

MODELLI DI TORNIO COMPATIBILI  
 COMPATIBLE LATHE TYPES

Dn Solutions | Doosan | Emco | Haas | Hanwha | Hardinge | Hwacheon | Hyundai WIA | Jyoti | Mylas | Nexturn | Romi | Samsung | Spinner | Takamaz | Takisawa Taiwan | Tornos | Victor

Vedi pagine compatibilità 5.14 / 5.20 - See compatibility pages 5.14 / 5.20

| Code        | Output      | Int Cool. | H   | h1   | Nm | Ratio | Rpm   | Kg | Sense of Rotation | Tech. Draw |
|-------------|-------------|-----------|-----|------|----|-------|-------|----|-------------------|------------|
| 99.DS.A88C  | ER-32 Ø2+20 | • 80 bar  | 65  | 93,6 | 35 | 1 : 1 | 8.000 | 6  |                   | ↓          |
| 99.DS.A98   | ER-25 Ø1+16 | -         | 100 | 84,9 | 20 | 1 : 1 | 6.000 | 7  |                   | ↓          |
| 99.DS.A68   | ER-25 Ø1+16 | • 80 bar  | 100 | 84,9 | 35 | 1 : 1 | 8.000 | 6  |                   | ↓          |
| 99.DS.A100  | PF-16 Ø16   | -         | 85  | 95   | 20 | 1 : 1 | 6.000 | 6  |                   | ↓          |
| 99.DS.A99C  | PF-16 Ø16   | -         | 65  | 95   | 35 | 1 : 1 | 8.000 | 6  |                   | ↓          |
| 99.DS.A100C | PF-16 Ø16   | -         | 85  | 95   | 35 | 1 : 1 | 8.000 | 6  |                   | ↓          |
| 99.DS.A101C | PF-16 Ø16   | -         | 100 | 95   | 35 | 1 : 1 | 8.000 | 6  |                   | ↓          |

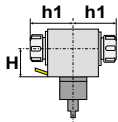

## RADIALE DOPPIO

### RADIAL DOUBLE

| Code       | Output                         | Int Cool. | H   | h1   | Nm | Ratio | Rpm   | Kg | Sense of Rotation | Tech. Draw |
|------------|--------------------------------|-----------|-----|------|----|-------|-------|----|-------------------|------------|
| 99.DS.A13  | ER-25 / Ø1+16 /<br>ER-25 Ø1+16 | -         | 65  | 84,9 | 20 | 1 : 1 | 6.000 | 5  |                   | ↓          |
| 99.DS.A103 | ER-25 Ø1+16                    | -         | 85  | 84,9 | 20 | 1 : 1 | 6.000 | 6  |                   | ↓          |
| 99.DS.A104 | ER-25 Ø1+16                    | -         | 100 | 84,9 | 35 | 1 : 1 | 8.000 | 6  |                   | ↓          |

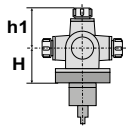

## ORIENTABILE

### ADJUSTABLE

| Code      | Output      | Int Cool. | H  | h1   | Nm | Ratio | Rpm   | Kg | Sense of Rotation | Tech. Draw |
|-----------|-------------|-----------|----|------|----|-------|-------|----|-------------------|------------|
| 99.DS.A16 | ER-20 Ø1+13 | -         | 65 | 52,5 | 15 | 1 : 1 | 6.000 | 3  |                   | ↓          |
| 99.DS.A17 | ER-20 Ø1+13 | • 80 bar  | 65 | 52,5 | 15 | 1 : 1 | 6.000 | 3  |                   | ↓          |

**ER** Portapinza  
Collet Holder

**PF** Portafresa  
Shell Mill Holder

 Ugualo al Mandrino  
Same as Spindle

 Opposto al Mandrino  
Opposite as Spindle

 Refrigerante Interno  
Internal Coolant

 Scarica il PDF  
PDF Download

MODELLI DI TORNIO COMPATIBILI  
 COMPATIBLE LATHE TYPES

 Accuway | Alex-Tech | Dn Solutions | Doosan | Emag | Emco | Goodway | Hardinge | Hwacheon  
 Hyundai WIA | Jyoti | Leadwell | Mazak | Romi | Samsung | Smart | Takamaz | Takisawa | Tongtai

Vedi pagine compatibilità 5.14 / 5.20 - See compatibility pages 5.14 / 5.20

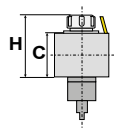

## ASSIALE AXIAL

SCAN IT TO SEE



THE TECHNICAL SHEETS

| Code      | Output      | Int Cool. | H    | C  | Nm | Ratio | Rpm    | Kg | Sense of Rotation | Tech. Draw |
|-----------|-------------|-----------|------|----|----|-------|--------|----|-------------------|------------|
| 99.DS.A01 | ER-25 Ø1÷16 | -         | 57.2 | 25 | 40 | 1 : 1 | 8.000  | 8  |                   | ↓          |
| 99.DS.A02 | ER-25 Ø1÷16 | • 80 bar  | 57.2 | 25 | 40 | 1 : 1 | 8.000  | 8  |                   | ↓          |
| 99.DS.A18 | ER-16 Ø1÷10 | -         | 86.5 | 57 | 12 | 1 : 4 | 32.000 | 3  |                   | ↓          |

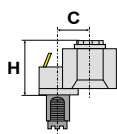

## ASSIALE DISASSATO AXIAL OFFSET

| Code      | Output      | Int Cool. | H    | C  | Nm | Ratio | Rpm    | Kg | Sense of Rotation | Tech. Draw |
|-----------|-------------|-----------|------|----|----|-------|--------|----|-------------------|------------|
| 99.DS.A19 | ER-16 Ø1÷10 | -         | 70.5 | 45 | 15 | 1 : 2 | 16.000 | 4  |                   | ↓          |

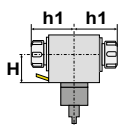

## RADIALE DOPPIO RADIAL DOUBLE

| Code      | Output                         | Int Cool. | H   | h1   | Nm | Ratio | Rpm   | Kg | Sense of Rotation | Tech. Draw |
|-----------|--------------------------------|-----------|-----|------|----|-------|-------|----|-------------------|------------|
| 99.DS.A94 | ER-25 / Ø1÷16 /<br>ER-25 Ø1÷16 | -         | 60  | 84,9 | 40 | 1 : 1 | 8.000 | 8  |                   | ↓          |
| 99.DS.A95 | ER-25 / Ø1÷16 /<br>ER-25 Ø1÷16 | -         | 85  | 84,9 | 30 | 1 : 1 | 6.000 | 8  |                   | ↓          |
| 99.DS.A96 | ER-25 / Ø1÷16 /<br>ER-25 Ø1÷16 | -         | 100 | 84,9 | 40 | 1 : 1 | 8.000 | 8  |                   | ↓          |
| 99.DS.A24 | ER-25 / Ø1÷16 /<br>ER-25 Ø1÷16 | -         | 70  | 84,9 | 40 | 1 : 1 | 8.000 | 8  |                   | ↓          |

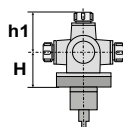

## ORIENTABILE ADJUSTABLE

| Code      | Output      | Int Cool. | H  | h1   | Nm | Ratio | Rpm   | Kg | Sense of Rotation | Tech. Draw |
|-----------|-------------|-----------|----|------|----|-------|-------|----|-------------------|------------|
| 99.DS.A23 | ER-20 Ø1÷13 | -         | 65 | 52,5 | 15 | 1 : 1 | 6.000 | 3  |                   | ↓          |
| 99.DS.A66 | ER-20 Ø1÷13 | • 80 bar  | 65 | 52,5 | 15 | 1 : 1 | 6.000 | 3  |                   | ↓          |

Disponibile versione con tenone maggiorato inserendo T dopo il codice. / Oversized tenon available - add "T" right after the code. (99.DS.A01T)

**ER** Portapinza  
Collet Holder

**PF** Portafresa  
Shell Mill Holder

 Ugualo al Mandrino  
Same as Spindle

 Opposto al Mandrino  
Opposite as Spindle

 Refrigerante Interno  
Internal Coolant

 Scarica il PDF  
PDF Download

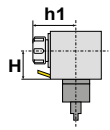

## RADIALE RADIAL



| Code        | Output      | Int Cool. | H   | h1   | Nm | Ratio | Rpm    | Kg | Sense of Rotation | Tech. Draw |
|-------------|-------------|-----------|-----|------|----|-------|--------|----|-------------------|------------|
| 99.DS.A11   | ER-25 Ø1÷16 | -         | 70  | 84,9 | 40 | 1 : 1 | 8.000  | 8  |                   |            |
| 99.DS.A11C  | ER-25 Ø1÷16 | -         | 70  | 84,9 | 40 | 1 : 1 | 8.000  | 8  |                   |            |
| 99.DS.A12   | ER-25 Ø1÷16 | ● 80 bar  | 70  | 84,9 | 40 | 1 : 1 | 8.000  | 8  |                   |            |
| 99.DS.A12C  | ER-25 Ø1÷16 | ● 80 bar  | 70  | 84,9 | 40 | 1 : 1 | 8.000  | 8  |                   |            |
| 99.DS.A20   | ER-16 Ø1÷10 | -         | 60  | 73,3 | 12 | 1 : 4 | 24.000 | 6  |                   |            |
| 99.DS.A21   | ER-16 Ø1÷10 | -         | 80  | 73,3 | 15 | 1 : 2 | 16.000 | 6  |                   |            |
| 99.DS.A105  | PF-16 Ø16   | -         | 60  | 95   | 40 | 1 : 1 | 8.000  | 8  |                   |            |
| 99.DS.A106  | PF-16 Ø16   | -         | 70  | 95   | 40 | 1 : 1 | 8.000  | 8  |                   |            |
| 99.DS.A107  | PF-16 Ø16   | -         | 85  | 95   | 40 | 1 : 1 | 8.000  | 8  |                   |            |
| 99.DS.A108  | PF-16 Ø16   | -         | 100 | 95   | 40 | 1 : 1 | 8.000  | 8  |                   |            |
| 99.DS.A69   | ER-25 Ø1÷16 | -         | 60  | 84,9 | 30 | 1 : 1 | 6.000  | 6  |                   |            |
| 99.DS.A69C  | ER-25 Ø1÷16 | -         | 60  | 84,9 | 30 | 1 : 1 | 6.000  | 6  |                   |            |
| 99.DS.A70   | ER-25 Ø1÷16 | ● 80 bar  | 60  | 84,9 | 30 | 1 : 1 | 6.000  | 6  |                   |            |
| 99.DS.A71   | ER-25 Ø1÷16 | -         | 85  | 84,9 | 30 | 1 : 1 | 6.000  | 7  |                   |            |
| 99.DS.A71C  | ER-25 Ø1÷16 | -         | 85  | 84,9 | 40 | 1 : 1 | 8.000  | 8  |                   |            |
| 99.DS.A72   | ER-25 Ø1÷16 | ● 80 bar  | 85  | 84,9 | 40 | 1 : 1 | 8.000  | 8  |                   |            |
| 99.DS.A72C  | ER-25 Ø1÷16 | ● 80 bar  | 85  | 84,9 | 40 | 1 : 1 | 8.000  | 8  |                   |            |
| 99.DS.A81   | ER-25 Ø1÷16 | -         | 100 | 84,9 | 40 | 1 : 1 | 8.000  | 8  |                   |            |
| 99.DS.A81C  | ER-25 Ø1÷16 | -         | 100 | 84,9 | 40 | 1 : 1 | 8.000  | 8  |                   |            |
| 99.DS.A82   | ER-25 Ø1÷16 | ● 80 bar  | 100 | 84,9 | 40 | 1 : 1 | 8.000  | 8  |                   |            |
| 99.DS.A82C  | ER-25 Ø1÷16 | ● 80 bar  | 100 | 84,9 | 40 | 1 : 1 | 8.000  | 8  |                   |            |
| 99.DS.A105C | PF-16 Ø16   | -         | 60  | 95   | 40 | 1 : 1 | 8.000  | 8  |                   |            |
| 99.DS.A106C | PF-16 Ø16   | -         | 70  | 95   | 40 | 1 : 1 | 8.000  | 8  |                   |            |
| 99.DS.A107C | PF-16 Ø16   | -         | 85  | 95   | 40 | 1 : 1 | 8.000  | 8  |                   |            |
| 99.DS.A108C | PF-16 Ø16   | -         | 100 | 95   | 40 | 1 : 1 | 8.000  | 8  |                   |            |

Disponibile versione con tenone maggiorato inserendo T dopo il codice. / Oversized tenon available - add "T" right after the code. (99.DS.A01T)

**ER** Portapinzina  
Collet Holder

**PF** Portafresa  
Shell Mill Holder

 Ugualo al Mandrino  
Same as Spindle

 Opposto al Mandrino  
Opposite as Spindle

 Refrigerante Interno  
Internal Coolant

 Scarica il PDF  
PDF Download

**MODELLI DI TORNIO COMPATIBILI**  
 COMPATIBLE LATHE TYPES

 Accuway | Dn Solutions | Doosan | Ecoca | Emag | Emco | Focus | Goodway | Haas | Hardinge | Hurco | Hwacheon  
 Hyundai | Johnford | Jyoti | Leadwell | Romi | Samsung | Smart | Spinner | Takisawa | Tongtai | Victor | Wele

Vedi pagine compatibilità 5.14 / 5.20 - See compatibility pages 5.14 / 5.20

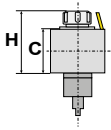

**ASSIALE**  
**AXIAL**

SCAN IT TO SEE

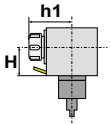

THE TECHNICAL SHEETS

| Code       | Output      | Int Cool. | H    | C  | Nm | Ratio | Rpm   | Kg | Sense of Rotation | Tech. Draw |
|------------|-------------|-----------|------|----|----|-------|-------|----|-------------------|------------|
| 99.DS.A41  | ER-32 Ø2+20 | -         | 72.2 | 32 | 70 | 1 : 1 | 6.000 | 10 |                   |            |
| 99.DS.A42  | ER-32 Ø2+20 | • 80 bar  | 72.2 | 32 | 50 | 1 : 1 | 6.000 | 4  |                   |            |
| 99.DS.A137 | ER-16 Ø1+10 | • 80 bar  | 66   | 32 | 40 | 1 : 1 | 6.000 | 3  |                   |            |

**RADIALE**  
**RADIAL**

| Code        | Output      | Int Cool. | H   | h1    | Nm | Ratio | Rpm    | Kg | Sense of Rotation | Tech. Draw |
|-------------|-------------|-----------|-----|-------|----|-------|--------|----|-------------------|------------|
| 99.DS.A51   | ER-32 Ø2+20 | -         | 72  | 93,6  | 70 | 1 : 1 | 6.000  | 10 |                   |            |
| 99.DS.A51C  | ER-32 Ø2+20 | -         | 72  | 93,6  | 70 | 1 : 1 | 6.000  | 10 |                   |            |
| 99.DS.A52   | ER-32 Ø2+20 | • 80 bar  | 72  | 93,6  | 70 | 1 : 1 | 6.000  | 10 |                   |            |
| 99.DS.A52C  | ER-32 Ø2+20 | • 80 bar  | 72  | 93,6  | 70 | 1 : 1 | 6.000  | 10 |                   |            |
| 99.DS.A73   | ER-32 Ø2+20 | -         | 100 | 93,6  | 70 | 1 : 1 | 6.000  | 10 |                   |            |
| 99.DS.A73C  | ER-32 Ø2+20 | -         | 100 | 93,6  | 70 | 1 : 1 | 6.000  | 10 |                   |            |
| 99.DS.A74   | ER-32 Ø2+20 | • 80 bar  | 100 | 93,6  | 70 | 1 : 1 | 6.000  | 10 |                   |            |
| 99.DS.A74C  | ER-32 Ø2+20 | • 80 bar  | 100 | 93,6  | 70 | 1 : 1 | 6.000  | 10 |                   |            |
| 99.DS.A30   | ER-20 Ø1+13 | -         | 72  | 93,6  | 12 | 1 : 4 | 12.000 | 7  |                   |            |
| 99.DS.A62   | PF-22 Ø22   | -         | 72  | 103,5 | 70 | 1 : 1 | 6.000  | 10 |                   |            |
| 99.DS.A62C  | PF-22 Ø22   | -         | 72  | 103,5 | 70 | 1 : 1 | 6.000  | 10 |                   |            |
| 99.DS.A111  | PF-22 Ø22   | -         | 100 | 103,5 | 70 | 1 : 1 | 6.000  | 10 |                   |            |
| 99.DS.A111C | PF-22 Ø22   | -         | 100 | 103,5 | 70 | 1 : 1 | 6.000  | 10 |                   |            |

Disponibile versione con tenone maggiorato inserendo T dopo il codice. / Oversized tenon available - add "T" right after the code. (99.DS.A27T)

**ER**

 Portapinza  
 Collet Holder

**PF**

 Portafresa  
 Shell Mill Holder

 Uguale al Mandrino  
 Same as Spindle

 Opposto al Mandrino  
 Opposite as Spindle

 Refrigerante Interno  
 Internal Coolant

 Scarica il PDF  
 PDF Download

MODELLI DI TORNIO COMPATIBILI  
 COMPATIBLE LATHE TYPES

 Accuway | Dn Solutions | Doosan | Ecoca | Emag | Emco | Focus | Goodway | Haas | Hardinge | Hurco | Hwacheon  
 Hyundai | Johnford | Jyoti | Leadwell | Romi | Samsung | Smart | Spinner | Takisawa | Tongtai | Victor | Wele

Vedi pagine compatibilità 5.14 / 5.20 - See compatibility pages 5.14 / 5.20

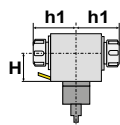

## RADIALE DOPPIO

### RADIAL DOUBLE

 SCAN IT TO SEE  
 THE TECHNICAL SHEETS

| Code      | Output                         | Int Cool. | H   | h1   | Nm | Ratio | Rpm   | Kg | Sense of Rotation | Tech. Draw |
|-----------|--------------------------------|-----------|-----|------|----|-------|-------|----|-------------------|------------|
| 99.DS.A31 | ER-32 / Ø2+20 /<br>ER-32 Ø2+20 | -         | 72  | 93,6 | 70 | 1 : 1 | 6.000 | 10 |                   | ↓          |
| 99.DS.A78 | ER-32 / Ø2+20 /<br>ER-32 Ø2+20 | -         | 100 | 93,6 | 70 | 1 : 1 | 6.000 | 10 |                   | ↓          |

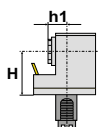

## RADIALE ARRETRATO

### RADIAL OFFSET

| Code       | Output      | Int Cool. | H   | h1   | Nm | Ratio | Rpm   | Kg | Sense of Rotation | Tech. Draw |
|------------|-------------|-----------|-----|------|----|-------|-------|----|-------------------|------------|
| 99.DS.A125 | ER-32 Ø2+20 | -         | 100 | 53,4 | 40 | 1 : 1 | 6.000 | 12 |                   | ↓          |

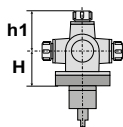

## ORIENTABILE

### ADJUSTABLE

| Code      | Output      | Int Cool. | H  | h1   | Nm | Ratio | Rpm   | Kg | Sense of Rotation | Tech. Draw |
|-----------|-------------|-----------|----|------|----|-------|-------|----|-------------------|------------|
| 99.DS.A64 | ER-25 Ø1+16 | -         | 75 | 67,2 | 25 | 1 : 1 | 6.000 | 5  |                   | ↓          |
| 99.DS.A65 | ER-25 Ø1+16 | • 80 bar  | 75 | 67,2 | 25 | 1 : 1 | 6.000 | 5  |                   | ↓          |

Disponibile versione con tenone maggiorato inserendo T dopo il codice. / Oversized tenon available - add "T" right after the code. (99.DS.A27T)

**ER** Portapinza  
 Collet Holder

**PF** Portafresa  
 Shell Mill Holder

 Ugualo al Mandrino  
 Same as Spindle

 Opposto al Mandrino  
 Opposite as Spindle

 Refrigerante Interno  
 Internal Coolant

 Scarica il PDF  
 PDF Download

MODELLI DI TORNIO COMPATIBILI  
 COMPATIBLE LATHE TYPES

 Dn Solutions | Doosan | Haas | Hwacheon | Hyundai WIA | Romi | Samsung | Smart  
 Takisawa | Victor

Vedi pagine compatibilità 5.14 / 5.20 - See compatibility pages 5.14 / 5.20

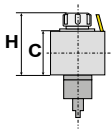

## ASSIALE AXIAL

SCAN IT TO SEE



THE TECHNICAL SHEETS

| Code      | Output      | Int Cool. | H    | C    | Nm | Ratio | Rpm   | Kg | Sense of Rotation | Tech. Draw |
|-----------|-------------|-----------|------|------|----|-------|-------|----|-------------------|------------|
| 99.DS.A34 | ER-40 Ø3+30 | -         | 90.2 | 52,6 | 60 | 1 : 1 | 6.000 | 6  |                   | ↓          |
| 99.DS.A35 | ER-40 Ø3+30 | • 80 bar  | 90.2 | 52,6 | 60 | 1 : 1 | 6.000 | 6  |                   | ↓          |

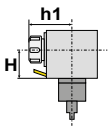

## RADIALE RADIAL

| Code       | Output      | Int Cool. | H   | h1    | Nm  | Ratio | Rpm   | Kg | Sense of Rotation | Tech. Draw |
|------------|-------------|-----------|-----|-------|-----|-------|-------|----|-------------------|------------|
| 99.DS.A38  | ER-40 Ø3+30 | -         | 60  | 112,1 | 60  | 1 : 1 | 6.000 | 12 |                   | ↓          |
| 99.DS.A38C | ER-40 Ø3+30 | -         | 60  | 112,1 | 100 | 1 : 1 | 6.000 | 12 |                   | ↓          |
| 99.DS.A39  | ER-40 Ø3+30 | • 80 bar  | 60  | 112,1 | 60  | 1 : 1 | 6.000 | 12 |                   | ↓          |
| 99.DS.A39C | ER-40 Ø3+30 | • 80 bar  | 60  | 112,1 | 100 | 1 : 1 | 6.000 | 12 |                   | ↓          |
| 99.DS.A138 | ER-40 Ø3+30 | -         | 60  | 112,5 | 100 | 1 : 1 | 6.000 | 12 |                   | ↓          |
| 99.DS.A75  | ER-40 Ø3+30 | -         | 90  | 112,1 | 60  | 1 : 1 | 6.000 | 15 |                   | ↓          |
| 99.DS.A75C | ER-40 Ø3+30 | -         | 90  | 112,1 | 100 | 1 : 1 | 6.000 | 12 |                   | ↓          |
| 99.DS.A76  | ER-40 Ø3+30 | • 80 bar  | 90  | 112,1 | 60  | 1 : 1 | 6.000 | 17 |                   | ↓          |
| 99.DS.A76C | ER-40 Ø3+30 | • 80 bar  | 90  | 112,1 | 100 | 1 : 1 | 6.000 | 12 |                   | ↓          |
| 99.DS.A85  | ER-40 Ø3+30 | -         | 110 | 112,1 | 60  | 1 : 1 | 6.000 | 17 |                   | ↓          |
| 99.DS.A85C | ER-40 Ø3+30 | -         | 110 | 112,1 | 100 | 1 : 1 | 6.000 | 12 |                   | ↓          |
| 99.DS.A86  | ER-40 Ø3+30 | • 80 bar  | 110 | 112,1 | 100 | 1 : 1 | 6.000 | 12 |                   | ↓          |
| 99.DS.A86C | ER-40 Ø3+30 | • 80 bar  | 110 | 112,1 | 100 | 1 : 1 | 6.000 | 12 |                   | ↓          |
| 99.DS.A112 | PF-27 Ø27   | -         | 60  | 120   | 100 | 1 : 1 | 6.000 | 12 |                   | ↓          |
| 99.DS.A113 | PF-27 Ø27   | -         | 90  | 120   | 60  | 1 : 1 | 6.000 | 15 |                   | ↓          |

**ER** Portapinza  
Collet Holder

**PF** Portafresa  
Shell Mill Holder

 Ugualo al Mandrino  
Same as Spindle

 Opposto al Mandrino  
Opposite as Spindle

 Refrigerante Interno  
Internal Coolant

 Scarica il PDF  
PDF Download

Vedi pagine compatibilità 5.14 / 5.20 - See compatibility pages 5.14 / 5.20

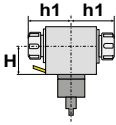

## RADIALE DOPPIO

### RADIAL DOUBLE



| Code      | Output                         | Int Cool. | H  | h1    | Nm  | Ratio | Rpm   | Kg | Sense of Rotation | Tech. Draw |
|-----------|--------------------------------|-----------|----|-------|-----|-------|-------|----|-------------------|------------|
| 99.DS.A44 | ER-40 / Ø3+30 /<br>ER-40 Ø3+30 | -         | 60 | 112,1 | 100 | 1 : 1 | 6.000 | 12 |                   | ↓          |

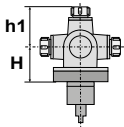

## ORIENTABILE

### ADJUSTABLE

| Code      | Output      | Int Cool. | H  | h1   | Nm | Ratio | Rpm   | Kg | Sense of Rotation | Tech. Draw |
|-----------|-------------|-----------|----|------|----|-------|-------|----|-------------------|------------|
| 99.DS.A47 | ER-25 Ø1+16 | -         | 75 | 67,2 | 25 | 1 : 1 | 6.000 | 7  |                   | ↓          |
| 99.DS.A48 | ER-25 Ø1+16 | • 80 bar  | 75 | 67,2 | 25 | 1 : 1 | 6.000 | 8  |                   | ↓          |

MODELLI DI TORNIO COMPATIBILI  
 COMPATIBLE LATHE TYPES

 Baruffaldi | Dn Solutions | Doosan | Emco | Focus | Hwacheon | Hyundai WIA | Samsung  
 Smart | Victor | Ycm

Vedi pagine compatibilità 5.14 / 5.20 - See compatibility pages 5.14 / 5.20

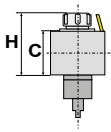

## ASSIALE AXIAL

SCAN IT TO SEE



THE TECHNICAL SHEETS

| Code      | Output      | Int Cool. | H     | C    | Nm  | Ratio | Rpm   | Kg | Sense of Rotation | Tech. Draw |
|-----------|-------------|-----------|-------|------|-----|-------|-------|----|-------------------|------------|
| 99.DS.A90 | ER-50 Ø6+36 | -         | 119.2 | 46,5 | 150 | 1 : 1 | 3.200 | 10 |                   |            |
| 99.DS.A50 | ER-50 Ø6+36 | • 80 bar  | 119.2 | 46,5 | 150 | 1 : 1 | 3.200 | 10 |                   |            |

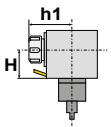

## RADIALE RADIAL

| Code       | Output      | Int Cool. | H   | h1    | Nm  | Ratio | Rpm   | Kg | Sense of Rotation | Tech. Draw |
|------------|-------------|-----------|-----|-------|-----|-------|-------|----|-------------------|------------|
| 99.DS.A77  | ER-50 Ø6+36 | -         | 85  | 147,7 | 150 | 1 : 1 | 3.200 | 21 |                   |            |
| 99.DS.A77C | ER-50 Ø6+36 | -         | 85  | 147,7 | 150 | 1 : 1 | 3.200 | 21 |                   |            |
| 99.DS.A56  | ER-50 Ø6+36 | • 80 bar  | 85  | 147,7 | 150 | 1 : 1 | 3.200 | 21 |                   |            |
| 99.DS.A56C | ER-50 Ø6+36 | • 80 bar  | 85  | 147,7 | 150 | 1 : 1 | 3.200 | 21 |                   |            |
| 99.DS.A89  | ER-50 Ø6+36 | -         | 110 | 147,7 | 150 | 1 : 1 | 3.200 | 21 |                   |            |
| 99.DS.A89C | ER-50 Ø6+36 | -         | 110 | 147,7 | 150 | 1 : 1 | 3.200 | 24 |                   |            |
| 99.DS.A57  | ER-50 Ø6+36 | • 80 bar  | 110 | 147,7 | 150 | 1 : 1 | 3.200 | 24 |                   |            |

NLX / NZ / SL-ZL-DL



**USCITA C. ISO26623**  
C. ISO26623 OUTPUT

Disponibile su richiesta  
Available on request



**DOTAZIONE STANDARD**  
STANDARD EQUIPMENT

Chiave bloccaggio albero / chiave per bloccaggio ghiera / ugello refrigerazione / viti bloccaggio motorizzato

Shaft lock wrench / nut lock wrench cooling nozzle Art.183 / nozzle lock screws / driven tool locking screws



**CAMBI RAPIDI MODULARI**  
MODULAR QUICK CHANGE

Facile e veloce sistema modulare per il cambio rapido delle diverse tipologie di portautensili con la sede per pinza ER (DIN6499).

Modular toolholder system for the fitting of toolholders in a spindle unit with ER collets (DIN6499) outputs.

Il valore della coppia, espresso in Nm, è il massimo consentito. Per una maggiore durata, si consiglia di mantenerlo sotto tale soglia  
The torque value, expressed in Nm, is the maximum allowed. For longer life, it is recommended to keep it below this limit

|          | c1 | c2  | d    | d1   | f   | f1 | f2 | f3 | f4 | h1  | h2     | h3   | i1  | i2  | t  |
|----------|----|-----|------|------|-----|----|----|----|----|-----|--------|------|-----|-----|----|
| NLX      | 20 | 5,5 | 60   | 23,7 | M12 | 94 | 84 | 15 | -  | 91  | 53     | 16,5 | 130 | 108 | 8  |
| NZ       | 12 | 4,5 | 40   | 22   | M10 | 70 | 62 | 16 | -  | 69  | 32     | 14,4 | 78  | 110 | 8  |
| SL-ZL-DL | 40 | 35  | 23,5 | 32   | M12 | 25 | 48 | 76 | 76 | 127 | 107,96 | 81   | 20  | 32  | 27 |

SL - ZL - DL

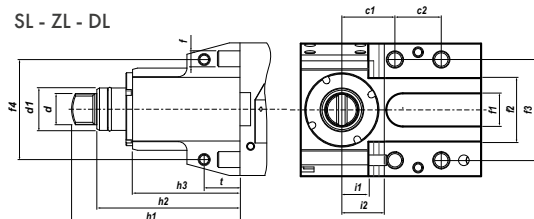

NLX

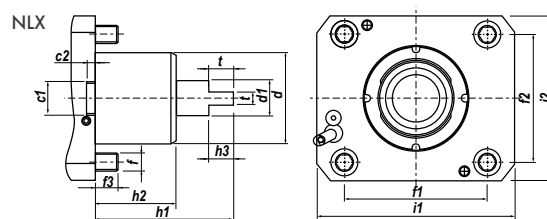

NZ

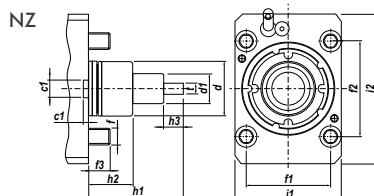

IN FASE D'ORDINE SPECIFICARE - IN CASE OF ORDER PLEASE SPECIFY:  
costruttore, modello e numero posizioni in torretta - machine builder, model and turret position numbers

MODELLI DI TORNO COMPATIBILI  
 COMPATIBLE LATHE TYPES

Vedi pagine compatibilità 5.14 / 5.20 - See compatibility pages 5.14 / 5.20

## ASSIALE - AXIAL

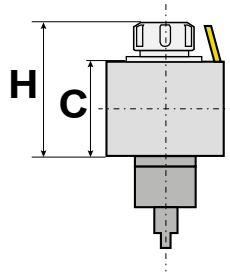
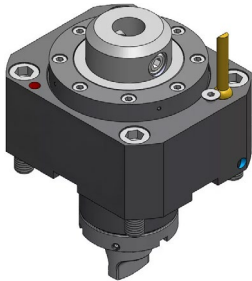

L'asse dell'utensile è in linea all'asse della torretta o del mandrino

The tool axis is aligned to the turret or spindle axis

**DISPONIBILE ANCHE CON TENONE MAGGIORATO**  
 ALSO AVAILABLE WITH BIGGER TENON

## ASSIALE 2 USCITE - AXIAL 2 OUTPUTS

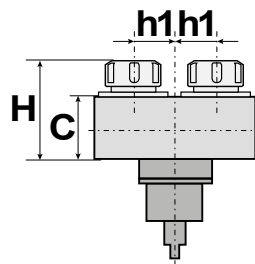
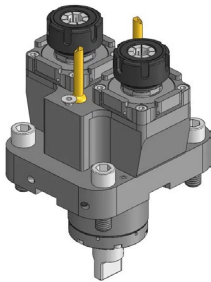

Un corpo unico ospita due uscite parallele orientate nella stessa direzione in linea con l'asse torretta

A single body contains two parallel outputs facing the same direction, aligned with the turret axis

## ASSIALE DISASSATO - OFFSET AXIS

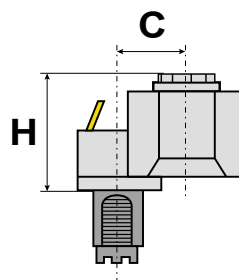
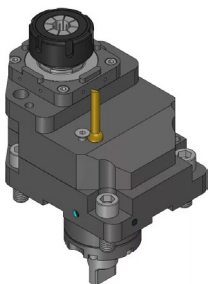

L'asse dell'utensile è in linea ma traslato rispetto all'asse della torretta

The tool axis is aligned with, but offset from, the turret axis

## RADIALE - RADIAL

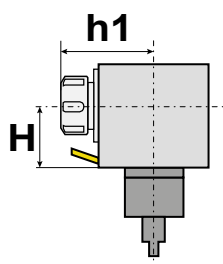
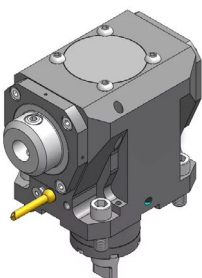

L'asse dell'utensile è perpendicolare all'asse della torretta o del mandrino

The tool axis is perpendicular to the turret or spindle axis

**DISPONIBILE ANCHE CON TENONE MAGGIORATO**  
 ALSO AVAILABLE WITH BIGGER TENON

## RADIALE DOPPIO - DOUBLE RADIAL

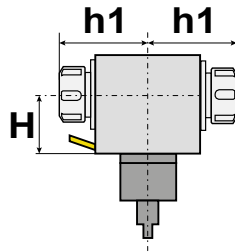
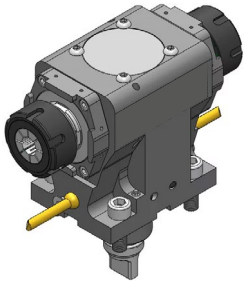

Il motorizzato ha due uscite situate sullo stesso asse radiale, ma rivolte in direzioni opposte

The driven tool has two outputs situated on the same radial axis, but facing in opposite directions

**DISPONIBILE ANCHE CON TENONE MAGGIORATO**  
 ALSO AVAILABLE WITH BIGGER TENON

## RADIALE ARRETRATO - RADIAL REAR OFFSET

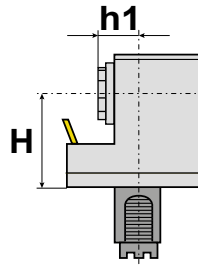
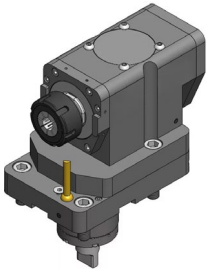

L'asse dell'utensile è perpendicolare all'asse della torretta o del mandrino ma traslato verso il corpo del motorizzato

The tool axis is perpendicular to the axis of the turret or spindle but offset towards the motorised unit

## RADIALE 8 USCITE - 8 OUTPUT RADIAL

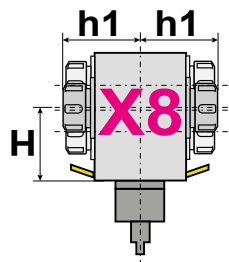
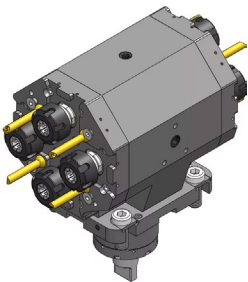

Il corpo del motorizzato è simmetrico rispetto all'asse della torretta e presenta 4 uscite sul lato sinistro e 4 uscite sul lato destro

The driven tool body is symmetrical in relation to the turret axis and has 4 outputs on the left side and 4 outputs on the right side

## RADIALE DOPPIO 2 USCITE SU ASSE Y - DOUBLE RADIAL 2 OUTPUTS ON Y AXIS

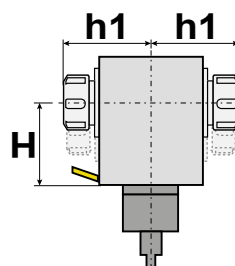
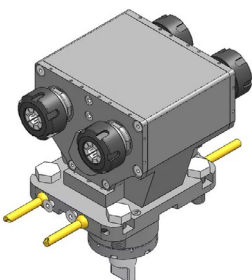

Due coppie di uscite parallele tra loro e distanziate lungo l'asse Y della macchina

Two pairs of outputs arranged in parallel and spaced apart along the machine's Y-axis

MODELLI DI TORNIO COMPATIBILI  
 COMPATIBLE LATHE TYPES

Vedi pagine compatibilità 5.14 / 5.20 - See compatibility pages 5.14 / 5.20

## RADIALE ROVESCiato - RADIAL UPSIDE DOWN

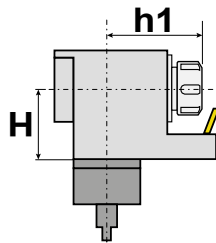
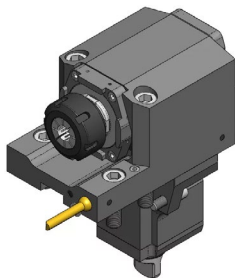

L'asse dell'utensile è perpendicolare all'asse della torretta o del mandrino ma con il tagliente rivolto in direzione opposta

The tool axis is perpendicular to the axis of the turret or spindle, but with the cutting edge facing in the opposite direction

## ORIENTABILE - ADJUSTABLE

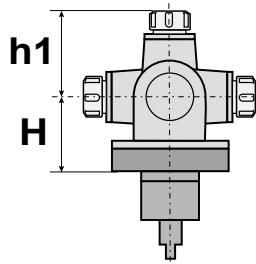
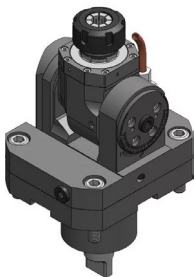

Permettono di inclinare l'asse dell'utensile secondo un angolo specifico richiesto dalla lavorazione

They allow the tool axis to be tilted to a specific angle required for the machining operation

## PORTA CREATORE - DRIVEN GEAR HOBBER

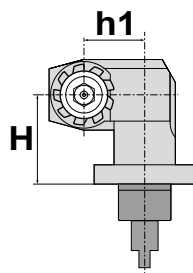
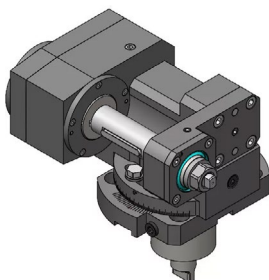

Dotato di una fresa specifica (creatore) su un albero rigido, montato su un supporto basculante

Equipped with a specific milling cutter on a rigid shaft, mounted on a pivoting support

MODELLI DI TORNO COMPATIBILI  
 COMPATIBLE LATHE TYPES

Vedi pagine compatibilità 5.14 / 5.20 - See compatibility pages 5.14 / 5.20

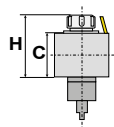

















## ASSIALE AXIAL

SCAN IT TO SEE



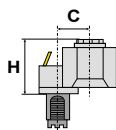

THE TECHNICAL SHEETS

| Code      | Output     | Int Cool. | H        | C    | Nm   | Ratio | Rpm   | Kg     | Sense of Rotation | Tech. Draw  |   |
|-----------|------------|-----------|----------|------|------|-------|-------|--------|-------------------|---|---|
| 99.MS.A01 | WELDON Ø20 | Ø20       | -        | 89   | 51   | 60    | 1 : 1 | 6.000  | 7                 |    | ↓ |
| 99.MS.A02 | WELDON Ø20 | Ø20       | • 80 bar | 89   | 52   | 60    | 1 : 1 | 6.000  | 7                 |    | ↓ |
| 99.MS.A03 | WELDON Ø25 | Ø25       | -        | 126  | 52   | 60    | 1 : 1 | 6.000  | 6                 |    | ↓ |
| 99.MS.A04 | WELDON Ø25 | Ø25       | • 80 bar | 126  | 84,5 | 60    | 1 : 1 | 6.000  | 7                 |    | ↓ |
| 99.MS.A05 | WELDON Ø20 | Ø20       | -        | 90   | 52   | 60    | 1 : 1 | 6.000  | 7                 |    | ↓ |
| 99.MS.A06 | WELDON Ø20 | Ø20       | • 80 bar | 90   | 52   | 60    | 1 : 1 | 6.000  | 7                 |    | ↓ |
| 99.MS.A59 | ER-32      | Ø2+20     | • 80 bar | 95.5 | 51   | 60    | 1 : 1 | 10.000 | 6                 |    | ↓ |
| 99.MS.A60 | ER-32      | Ø2+20     | -        | 95.5 | 51   | 60    | 1 : 1 | 10.000 | 6                 |    | ↓ |
| 99.MS.A62 | ER-40      | Ø3+30     | -        | 92   | 51   | 60    | 1 : 1 | 10.000 | 6                 |    | ↓ |
| 99.MS.A63 | ER-40      | Ø3+30     | • 80 bar | 92   | 51   | 60    | 1 : 1 | 10.000 | 10                |    | ↓ |
| 99.MS.A67 | PF-22      | Ø22       | -        | 100  | 51   | 60    | 1 : 1 | 6.000  | 10                |  | ↓ |
| 99.MS.A68 | PF-27      | Ø27       | -        | 100  | 51   | 60    | 1 : 1 | 6.000  | 10                |  | ↓ |
| 99.MS.A80 | ER-25      | Ø1+16     | -        | 94   | 51   | 60    | 1 : 1 | 10.000 | 6                 |  | ↓ |
| 99.MS.A81 | ER-25      | Ø1+16     | • 80 bar | 94   | 51   | 60    | 1 : 1 | 10.000 | 6                 |  | ↓ |
| 99.MS.A89 | CAPTO C5   | ISO26623  | -        | 85.5 | 69   | 100   | 1 : 1 | 10.000 | 8.991             |  | ↓ |
| 99.MS.A91 | CAPTO C5   | ISO26623  | • 80 bar | 85.5 | 52   | 100   | 1 : 1 | 10.000 | 8.991             |  | ↓ |



## ASSIALE DISASSATO AXIAL OFFSET

| Code       | Output   | Int Cool. | H | C   | Nm | Ratio | Rpm   | Kg     | Sense of Rotation | Tech. Draw  |   |
|------------|----------|-----------|---|-----|----|-------|-------|--------|-------------------|---|---|
| 99.MS.A111 | CAPTO C4 | ISO26623  | - | 125 |    | 50    | 1 : 1 | 12.000 | 7.5               |  | ↓ |
| 99.MS.A61  | ER-32    | Ø2+20     | - | 125 | 45 | 80    | 1 : 1 | 10.000 | 8                 |  | ↓ |

Disponibile solo per tornio NZ 1000 / Only for lathe NZ 1000

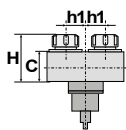

## ASSIALE 2 USCITE AXIAL 2 OUTPUTS

| Code      | Output                         | Int Cool. | H     | C  | Nm | Ratio | Rpm   | Kg | Sense of Rotation | Tech. Draw |
|-----------|--------------------------------|-----------|-------|----|----|-------|-------|----|-------------------|------------|
| 99.MS.A57 | ER-25 / Ø1+16 /<br>ER-25 Ø1+16 | -         | 117.5 | 85 | 40 | 1 : 1 | 6.000 | 10 |                   |            |
| 99.MS.A58 | ER-25 / Ø1+16 /<br>ER-25 Ø1+16 | • 80 bar  | 117.5 | 85 | 40 | 1 : 1 | 6.000 | 10 |                   |            |

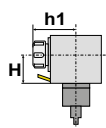

## RADIALE RADIAL

| Code      | Output               | Int Cool. | H  | h1    | Nm  | Ratio | Rpm    | Kg     | Sense of Rotation | Tech. Draw |
|-----------|----------------------|-----------|----|-------|-----|-------|--------|--------|-------------------|------------|
| 99.MS.A07 | WELDON Ø20<br>Ø20    | -         | 90 | 109   | 60  | 1 : 1 | 10.000 | 10     |                   |            |
| 99.MS.A08 | WELDON Ø20<br>Ø20    | • 80 bar  | 90 | 109   | 60  | 1 : 1 | 10.000 | 10     |                   |            |
| 99.MS.A09 | WELDON Ø25<br>Ø25    | -         | 90 | 101   | 60  | 1 : 1 | 6.000  | 11     |                   |            |
| 99.MS.A10 | WELDON Ø25<br>Ø25    | • 80 bar  | 90 | 139   | 60  | 1 : 1 | 6.000  | 11     |                   |            |
| 99.MS.A11 | WELDON Ø 1"<br>Ø25,4 | -         | 90 | 139   | 60  | 1 : 1 | 10.000 | 10     |                   |            |
| 99.MS.A12 | WELDON Ø 1"<br>Ø25,4 | • 80 bar  | 90 | 139   | 60  | 1 : 1 | 10.000 | 10     |                   |            |
| 99.MS.A13 | WELDON Ø32<br>Ø32    | -         | 90 | 137   | 60  | 1 : 1 | 10.000 | 11.374 |                   |            |
| 99.MS.A14 | WELDON Ø32<br>Ø32    | • 80 bar  | 90 | 105   | 60  | 1 : 1 | 10.000 | 11.381 |                   |            |
| 99.MS.A69 | PF-22<br>Ø22         | -         | 90 | 67,7  | 60  | 1 : 1 | 6.000  | 10     |                   |            |
| 99.MS.A70 | PF-27<br>Ø27         | -         | 90 | 67,7  | 60  | 1 : 1 | 6.000  | 10     |                   |            |
| 99.MS.A72 | ER-32<br>Ø2+20       | -         | 90 | 103,9 | 60  | 1 : 1 | 10.000 | 9      |                   |            |
| 99.MS.A73 | ER-32<br>Ø2+20       | • 80 bar  | 90 | 103,9 | 60  | 1 : 1 | 10.000 | 10     |                   |            |
| 99.MS.A76 | ER-40<br>Ø3+30       | -         | 90 | 107,5 | 60  | 1 : 1 | 10.000 | 9      |                   |            |
| 99.MS.A77 | ER-40<br>Ø3+30       | • 80 bar  | 90 | 113   | 60  | 1 : 1 | 10.000 | 9      |                   |            |
| 99.MS.A82 | ER-25<br>Ø1+16       | -         | 90 | 99    | 60  | 1 : 1 | 10.000 | 10     |                   |            |
| 99.MS.A83 | ER-25<br>Ø1+16       | • 80 bar  | 90 | 99    | 60  | 1 : 1 | 10.000 | 10     |                   |            |
| 99.MS.A88 | PF-16<br>Ø16         | -         | 90 | 66,5  | 60  | 1 : 1 | 6.000  | 10.201 |                   |            |
| 99.MS.A95 | CAPTO C5<br>ISO26623 | • 80 bar  | 90 | 95    | 100 | 1 : 1 | 10.000 | 5.2    |                   |            |

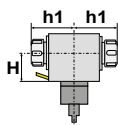

## RADIALE DOPPIO

### RADIAL DOUBLE

| Code      | Output                         | Int Cool. | H  | h1    | Nm | Ratio | Rpm    | Kg | Sense of Rotation | Tech. Draw |
|-----------|--------------------------------|-----------|----|-------|----|-------|--------|----|-------------------|------------|
| 99.MS.A84 | ER-32 / Ø2+20 /<br>ER-32 Ø2+20 | -         | 90 | 103,9 | 60 | 1 : 1 | 10.000 | 10 |                   | ↓          |
| 99.MS.A85 | ER-40 / Ø3+30 /<br>ER-40 Ø3+30 | -         | 90 | 106   | 60 | 1 : 1 | 10.000 | 10 |                   | ↓          |

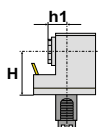

## RADIALE ARRETRATO

### RADIAL OFFSET

| Code      | Output      | Int Cool. | H   | h1   | Nm | Ratio | Rpm    | Kg | Sense of Rotation | Tech. Draw |
|-----------|-------------|-----------|-----|------|----|-------|--------|----|-------------------|------------|
| 99.MS.A74 | ER-32 Ø2+20 | -         | 100 | 54,5 | 60 | 1 : 1 | 10.000 | 11 |                   | ↓          |
| 99.MS.A75 | ER-32 Ø2+20 | • 80 bar  | 100 | 54,5 | 60 | 1 : 1 | 10.000 | 12 |                   | ↓          |

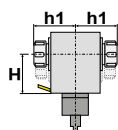

## RADIALE DOPPIO 2 USCITE SU ASSE Y

### DOUBLE RADIAL 2 OUTPUTS ON Y AXIS

| Code      | Output                         | Int Cool. | H  | h1  | Nm | Ratio | Rpm   | Kg  | Sense of Rotation | Tech. Draw |
|-----------|--------------------------------|-----------|----|-----|----|-------|-------|-----|-------------------|------------|
| 99.MS.A96 | ER-25 / Ø1+16 /<br>ER-25 Ø1+16 | -         | 90 | 101 | 40 | 1 : 1 | 6.000 | 2.1 |                   | ↓          |

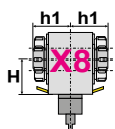

## RADIALE 8 USCITE

### 8 OUPUT RADIAL

| Code      | Output                 | Int Cool. | H  | h1  | Nm | Ratio | Rpm   | Kg | Sense of Rotation | Tech. Draw |
|-----------|------------------------|-----------|----|-----|----|-------|-------|----|-------------------|------------|
| 99.MS.A97 | ER-20 /<br>ER-20 Ø1+13 | -         | 90 | 101 | 20 | 1 : 1 | 6.000 | 19 |                   | ↓          |

Vedi pagine compatibilità 5.14 / 5.20 - See compatibility pages 5.14 / 5.20

SCAN IT TO SEE



THE TECHNICAL SHEETS

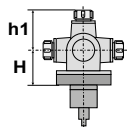

## ORIENTABILE ADJUSTABLE

| Code      | Output      | Int Cool. | H  | h1 | Nm | Ratio | Rpm    | Kg | Sense of Rotation | Tech. Draw |
|-----------|-------------|-----------|----|----|----|-------|--------|----|-------------------|------------|
| 99.MS.A86 | ER-25 Ø1÷16 | -         | 78 | 35 | 25 | 1 : 1 | 10.000 | 5  |                   |            |
| 99.MS.A87 | ER-25 Ø1÷16 | • 80 bar  |    |    | 25 | 1 : 1 | 10.000 | 8  |                   |            |

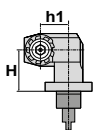

## PORTA CREATORE DRIVEN GEAR HOBBER

| Code      | Output | Int Cool. | H      | C     | Nm  | Ratio | Rpm   | Kg | Sense of Rotation | Tech. Draw |
|-----------|--------|-----------|--------|-------|-----|-------|-------|----|-------------------|------------|
| 99.MS.A15 | Ø27    | -         | 102    | 1.418 | 110 | 2 : 1 | 3.000 | 18 |                   |            |
| 99.MS.A99 | Ø22    | -         | 101.77 | 141,8 | 150 | 2 : 1 | 3.000 |    |                   |            |

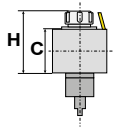

## ASSIALE AXIAL

SCAN IT TO SEE



THE TECHNICAL SHEETS

| Code       | Output      | Int Cool. | H    | C  | Nm | Ratio | Rpm    | Kg  | Sense of Rotation | Tech. Draw |
|------------|-------------|-----------|------|----|----|-------|--------|-----|-------------------|------------|
| 99.MS.A101 | ER-25 Ø1+16 | -         | 84.3 | 35 | 50 | 1 : 1 | 12.000 | 7.5 |                   | ↓          |
| 99.MS.A102 | ER-25 Ø1+16 | • 100 bar | 84.3 | 35 | 50 | 1 : 1 | 12.000 | 7.5 |                   | ↓          |
| 99.MS.A103 | ER-32 Ø2+20 | -         | 89.2 | 35 | 50 | 1 : 1 | 12.000 | 7.5 |                   | ↓          |
| 99.MS.A104 | ER-32 Ø2+20 | • 100 bar | 89.2 | 35 | 50 | 1 : 1 | 12.000 | 7.5 |                   | ↓          |
| 99.MS.A105 | PF-22 Ø22   | -         | 100  | 35 | 50 | 1 : 1 | 12.000 | 7.5 |                   | ↓          |

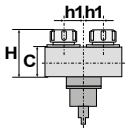

## ASSIALE 2 USCITE AXIAL 2 OUTPUTS

| Code       | Output              | Int Cool. | H    | C  | Nm | Ratio | Rpm   | Kg  | Sense of Rotation | Tech. Draw |
|------------|---------------------|-----------|------|----|----|-------|-------|-----|-------------------|------------|
| 99.MS.A121 | ER-20 / ER-20 Ø1+13 | -         | 91.5 | 66 | 30 | 1 : 1 | 6.000 | 5.5 |                   | ↓          |
| 99.MS.A122 | ER-20 / ER-20 Ø1+13 | • 80 bar  | 91.5 | 66 | 30 | 1 : 1 | 6.000 | 5.5 |                   | ↓          |

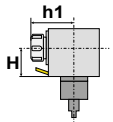

## RADIALE RADIAL

| Code       | Output      | Int Cool. | H  | h1 | Nm | Ratio | Rpm    | Kg  | Sense of Rotation | Tech. Draw |
|------------|-------------|-----------|----|----|----|-------|--------|-----|-------------------|------------|
| 99.MS.A106 | ER-25 Ø1+16 | -         | 85 | 94 | 50 | 1 : 1 | 12.000 | 7.5 |                   | ↓          |
| 99.MS.A107 | ER-25 Ø1+16 | • 100 bar | 85 | 94 | 50 | 1 : 1 | 12.000 | 7.5 |                   | ↓          |
| 99.MS.A108 | ER-32 Ø2+20 | -         | 85 | 94 | 50 | 1 : 1 | 12.000 | 7.5 |                   | ↓          |
| 99.MS.A109 | ER-32 Ø2+20 | • 100 bar | 85 | 94 | 50 | 1 : 1 | 12.000 | 7.5 |                   | ↓          |

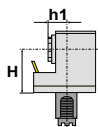

## RADIALE ARRETRATO RADIAL OFFSET

SCAN IT TO SEE



THE TECHNICAL SHEETS

| Code       | Output      | Int Cool. | H   | h1   | Nm | Ratio | Rpm    | Kg  | Sense of Rotation | Tech. Draw |
|------------|-------------|-----------|-----|------|----|-------|--------|-----|-------------------|------------|
| 99.MS.A123 | ER-25 Ø1+16 | -         | 125 | 54,1 | 50 | 1 : 1 | 12.000 | 7.5 |                   | ↓          |
| 99.MS.A124 | ER-25 Ø1+16 | • 100 bar | 125 | 54,1 | 50 | 1 : 1 | 12.000 | 7.5 |                   | ↓          |
| 99.MS.A125 | ER-32 Ø2+20 | -         | 125 | 59   | 50 | 1 : 1 | 12.000 | 7.5 |                   | ↓          |
| 99.MS.A126 | ER-32 Ø2+20 | • 100 bar | 125 | 59   | 50 | 1 : 1 | 12.000 | 7.5 |                   | ↓          |

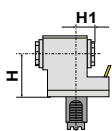

## RADIALE DOPPIO ARRETRATO RADIAL DOUBLE OFFSET

| Code       | Output                         | Int Cool. | H   | h1   | Nm | Ratio | Rpm    | Kg  | Sense of Rotation | Tech. Draw |
|------------|--------------------------------|-----------|-----|------|----|-------|--------|-----|-------------------|------------|
| 99.MS.A128 | ER-25 / Ø1+16 /<br>ER-25 Ø1+16 | -         | 125 | 54,1 | 50 | 1 : 1 | 12.000 | 7.5 |                   | ↓          |
| 99.MS.A129 | ER-32 / Ø2+20 /<br>ER-32 Ø2+20 | -         | 125 | 59   | 50 | 1 : 1 | 12.000 | 7.5 |                   | ↓          |

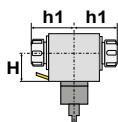

## RADIALE DOPPIO RADIAL DOUBLE

| Code       | Output                         | Int Cool. | H  | h1 | Nm | Ratio | Rpm    | Kg  | Sense of Rotation | Tech. Draw |
|------------|--------------------------------|-----------|----|----|----|-------|--------|-----|-------------------|------------|
| 99.MS.A114 | ER-32 / Ø2+20 /<br>ER-32 Ø2+20 | -         | 85 | 94 | 50 | 1 : 1 | 12.000 | 7.5 |                   | ↓          |
| 99.MS.A115 | ER-25 / Ø1+16 /<br>ER-25 Ø1+16 | -         | 85 | 89 | 50 | 1 : 1 | 12.000 | 7.5 |                   | ↓          |

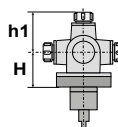

## ORIENTABILE ADJUSTABLE

| Code       | Output      | Int Cool. | H  | h1   | Nm | Ratio | Rpm    | Kg  | Sense of Rotation | Tech. Draw |
|------------|-------------|-----------|----|------|----|-------|--------|-----|-------------------|------------|
| 99.MS.A118 | ER-20 Ø1+13 | -         | 50 | 57,1 | 17 | 1 : 1 | 12.000 | 5.5 |                   | ↓          |
| 99.MS.A119 | ER-20 Ø1+13 | • 80 bar  | 50 | 57,1 | 17 | 1 : 1 | 12.000 | 5.5 |                   | ↓          |

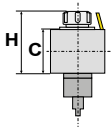

## ASSIALE AXIAL

| Code      | Output      | Int Cool. | H  | C  | Nm | Ratio | Rpm   | Kg | Sense of Rotation | Tech. Draw |
|-----------|-------------|-----------|----|----|----|-------|-------|----|-------------------|------------|
| 99.MS.A28 | ER-32 Ø2+20 | -         | 60 | 30 | 70 | 1 : 1 | 6.000 | 10 |                   | ↓          |
| 99.MS.A29 | ER-32 Ø2+20 | • 80 bar  | 60 | 30 | 70 | 1 : 1 | 6.000 | 10 |                   | ↓          |

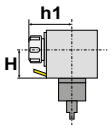

## RADIALE RADIAL

| Code      | Output      | Int Cool. | H  | h1   | Nm | Ratio | Rpm   | Kg | Sense of Rotation | Tech. Draw |
|-----------|-------------|-----------|----|------|----|-------|-------|----|-------------------|------------|
| 99.MS.A33 | ER-32 Ø2+20 | -         | 55 | 93,5 | 70 | 1 : 1 | 6.000 | 10 |                   | ↓          |
| 99.MS.A34 | ER-32 Ø2+20 | • 80 bar  | 55 | 93,5 | 70 | 1 : 1 | 6.000 | 10 |                   | ↓          |

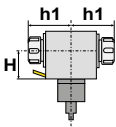

## RADIALE DOPPIO RADIAL DOUBLE

| Code      | Output                         | Int Cool. | H  | h1   | Nm | Ratio | Rpm   | Kg | Sense of Rotation | Tech. Draw |
|-----------|--------------------------------|-----------|----|------|----|-------|-------|----|-------------------|------------|
| 99.MS.A49 | ER-32 / Ø2+20 /<br>ER-32 Ø2+20 | -         | 55 | 93,5 | 70 | 1 : 1 | 6.000 | 10 |                   | ↓          |

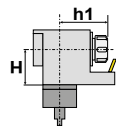

## RADIALE ROVESCiato RADIAL UPSIDE DOWN

| Code      | Output      | Int Cool. | H  | h1   | Nm | Ratio | Rpm   | Kg | Sense of Rotation | Tech. Draw |
|-----------|-------------|-----------|----|------|----|-------|-------|----|-------------------|------------|
| 99.MS.A41 | ER-32 Ø2+20 | -         | 55 | 93,5 | 70 | 1 : 1 | 6.000 | 10 |                   | ↓          |
| 99.MS.A42 | ER-32 Ø2+20 | • 80 bar  | 55 | 93,5 | 70 | 1 : 1 | 6.000 | 10 |                   | ↓          |

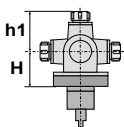

## ORIENTABILE ADJUSTABLE

| Code      | Output      | Int Cool. | H  | h1 | Nm | Ratio | Rpm   | Kg | Sense of Rotation | Tech. Draw |
|-----------|-------------|-----------|----|----|----|-------|-------|----|-------------------|------------|
| 99.MS.A55 | ER-20 Ø1+13 | -         | 66 | 56 | 25 | 1 : 1 | 6.000 | 6  |                   | ↓          |
| 99.MS.A56 | ER-20 Ø1+13 | • 80 bar  | 25 | 56 | 25 | 1 : 1 | 6.000 | 6  |                   | ↓          |



# MODULAR QUICK CHANGE ADAPTORS



COMPATIBILI CON TUTTE LE USCITE ER - COMPATIBLE WITH ALL ER OUTPUTS

## SISTEMA MODULARE MODULAR SYSTEM

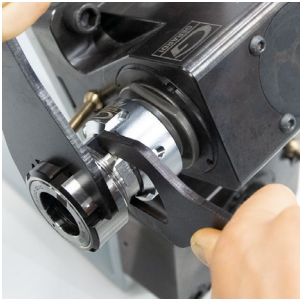

Facile e veloce sistema modulare universale per cambiare rapidamente diverse tipologie di utensili.

An easy modular system to replace quickly any tool you need.

## VANTAGGI ADVANTAGES



Aiutano a ridurre i costi-extra per l'acquisto di nuovi motorizzati o teste angolari.

The costs for further requirements of spindle units can be reduced by using the universal quick change adaptors

## ALTE PRESTAZIONI HIGH PERFORMANCE



Ghiera con cuscinetto a sfera e losanga di trascinamento removibile per una maggiore rigidità.

High rigidity thanks to the ball bearing nut and the removable diamond plate

## COMPATIBILITÀ COMPATIBILITY



Ampia gamma di uscite disponibili adatte al montaggio su qualsiasi tipologia di motorizzato o testa angolare con uscita ER

Wide range of outputs available. Ball bearing nut and removable diamond plate for highest rigidity.

I cambi rapidi modulari Gerardi mantenendo il presetting precedentemente realizzato consentono un notevole risparmio dei costi ed un ottimizzazione dei tempi ciclo. Sono perfettamente compatibili con tutti i motorizzati e le teste angolari aventi uscita ER DIN6499 e possono essere utilizzati sia con refrigerante interno che esterno.

The Gerardi modular quick change adaptors keep the tool presetting previously made and allow great costs and machining times saving. They are perfectly compatible with all driven tools and angle head with ER DIN6499 output and they can be used with internal or external coolant.

- Nuovi cambi rapidi modulari 2.0 a FORTE SERRAGGIO, 100% Made in Italy.
- Prestazioni garantite e maggior rigidità sui motorizzati Gerardi grazie alla losanga di trascinamento (rimovibile) e alla ghiera con cuscinetto a sfera.
- Adattabili a motorizzati con uscita refrigerante sia interna che esterna.
- Si consiglia di non superare i 10.000 Rpm utilizzando i cambi rapidi

- Universal HIGH TORQUE modular quick change adaptor 100% Made in Italy.
- Guaranteed higher rigidity and performances on Gerardi driven tools thanks to the removable diamond plate and the ball bearing nut
- Suitable for ER toolholder with external and internal coolant supply
- Using the quick change adaptors, we suggest not to exceed 10.000 Rpm

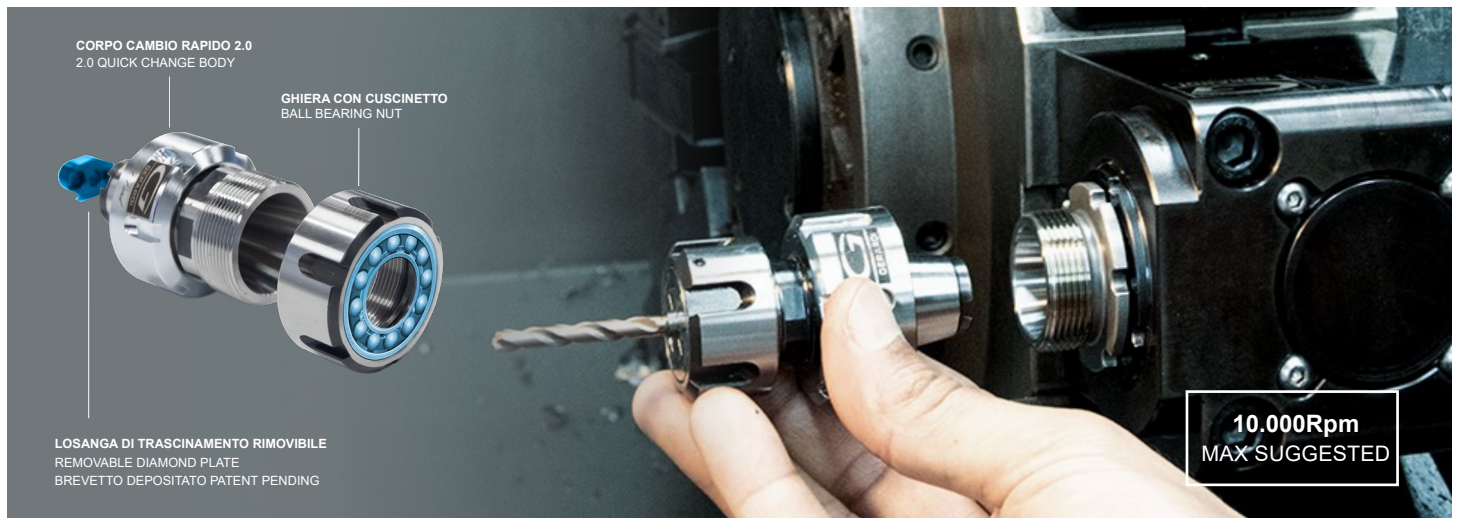

Vedi Pagine 7.14 - 7.15 - See pages 7.14 - 7.15



ER OUTPUTS COMPATIBLE



2 YEARS GUARANTEED



100% MADE IN ITALY

G1 / G4

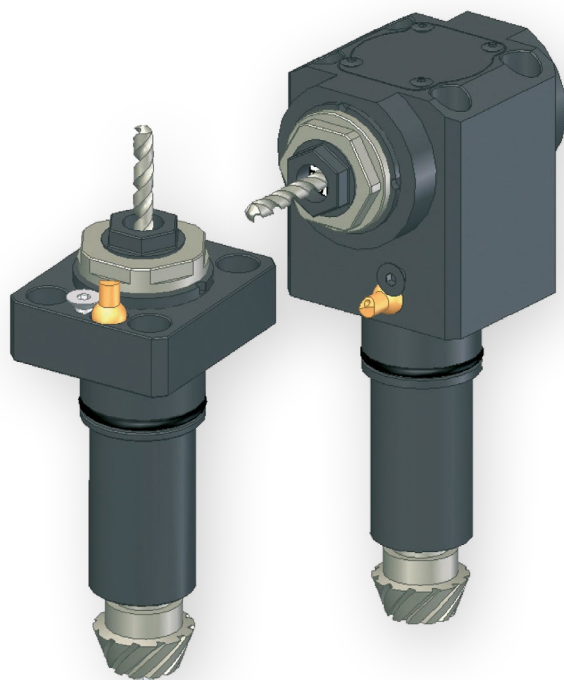

**DOTAZIONE STANDARD**  
**STANDARD EQUIPMENT**



Chiave bloccaggio albero / ugello refrigerazione / vite bloccaggio ugello / viti bloccaggio motorizzato O-ring

Tool shaft lock wrench / cooling nozzle / nozzle lock screws / Driven tool locking screws / O-ring

**CAMBI RAPIDI MODULARI**  
**MODULAR QUICK CHANGE**



Facile e veloce sistema modulare per il cambio rapido delle diverse tipologie di portautensili con la sede per pinza ER (DIN6499).

Modular toolholder system for the fitting of toolholders in a spindle unit with ER collets (DIN6499) outputs.

Il valore della coppia, espresso in Nm, è il massimo consentito. Per una maggiore durata, si consiglia di mantenerlo sotto tale soglia  
 The torque value, expressed in Nm, is the maximum allowed. For longer life, it is recommended to keep it below this limit

| Type | A     |
|------|-------|
| G1   | 42 h6 |

| Type | d   | d2   | f | f1 | f2 | f3 | h1 | h3 | i1  | i2  | t | t1   |
|------|-----|------|---|----|----|----|----|----|-----|-----|---|------|
| G4   | Ø60 | 23,7 | - | 84 | 94 | 15 | 91 | 55 | 108 | 130 | 8 | 16,5 |

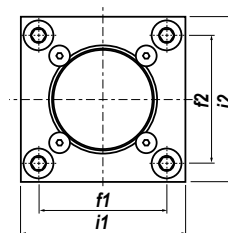
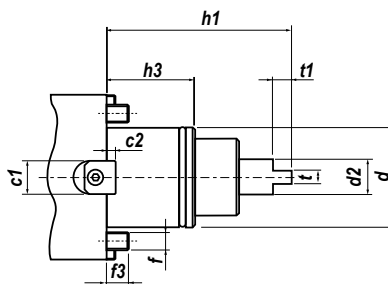
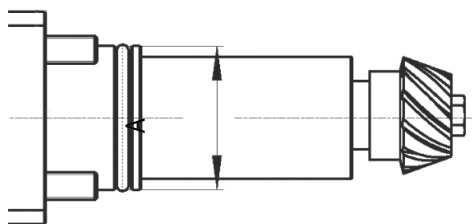

IN FASE D'ORDINE SPECIFICARE - IN CASE OF ORDER PLEASE SPECIFY:  
 costruttore, modello e numero posizioni in torretta - machine builder, model and turret position numbers

## ASSIALE - AXIAL

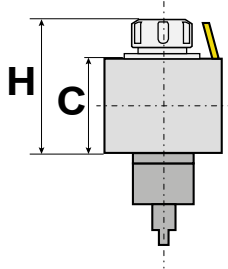
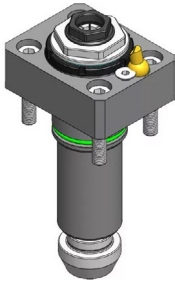

L'asse dell'utensile è in linea all'asse della torretta o del mandrino

The tool axis is aligned to the turret or spindle axis

## RADIALE - RADIAL

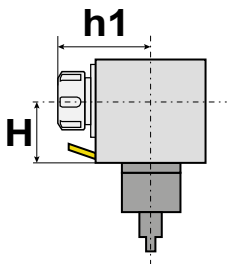

L'asse dell'utensile è perpendicolare all'asse della torretta o del mandrino

The tool axis is perpendicular to the turret or spindle axis

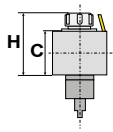

## ASSIALE AXIAL



| Code      | Output      | Int Cool. | H  | C    | Nm | Ratio | Rpm   | Kg | Sense of Rotation | Tech. Draw |
|-----------|-------------|-----------|----|------|----|-------|-------|----|-------------------|------------|
| 99.GD.A01 | ER-20 Ø1÷13 | -         | 40 | 26,5 | 25 | 1 : 1 | 6.000 | 2  |                   |            |

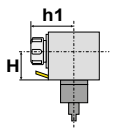

## RADIALE RADIAL

| Code      | Output      | Int Cool. | H  | h1 | Nm | Ratio | Rpm   | Kg | Sense of Rotation | Tech. Draw |
|-----------|-------------|-----------|----|----|----|-------|-------|----|-------------------|------------|
| 99.GD.A02 | ER-20 Ø1÷13 | -         | 60 | 58 | 25 | 1 : 1 | 6.000 | 4  |                   |            |

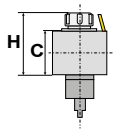

## ASSIALE AXIAL



| Code      | Output      | Int Cool. | H  | C    | Nm | Ratio | Rpm   | Kg | Sense of Rotation | Tech. Draw |
|-----------|-------------|-----------|----|------|----|-------|-------|----|-------------------|------------|
| 99.GD.A07 | ER-40 Ø3÷30 | -         | 92 | 51,3 | 70 | 1 : 1 | 6.000 | 6  |                   |            |
| 99.GD.A08 | ER-40 Ø3÷30 | 70 bar    | 92 | 51,3 | 70 | 1 : 1 | 6.000 | 4  |                   |            |

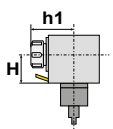

## RADIALE RADIAL

| Code      | Output      | Int Cool. | H     | h1 | Nm | Ratio | Rpm   | Kg | Sense of Rotation | Tech. Draw |
|-----------|-------------|-----------|-------|----|----|-------|-------|----|-------------------|------------|
| 99.GD.A09 | ER-40 Ø3÷30 | -         | 105.5 | 67 | 63 | 1 : 1 | 6.000 | 10 |                   |            |
| 99.GD.A10 | ER-40 Ø3÷30 | 70 bar    | 105.5 | 67 | 63 | 1 : 1 | 6.000 | 10 |                   |            |



**NUOVI MOTORIZZATI POTENZIATI DISPONIBILI !!**  
NEW UPGRADED DRIVEN TOOLS AVAILABLE !!

**SCARICA  
IL CAPITOLO  
DOWNLOAD  
THE CHAPTER !!**

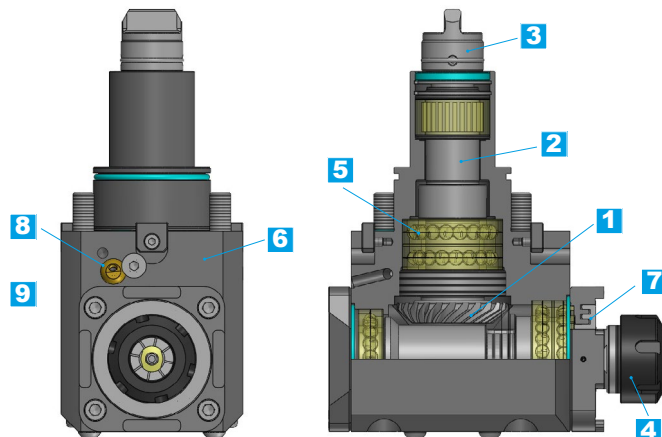
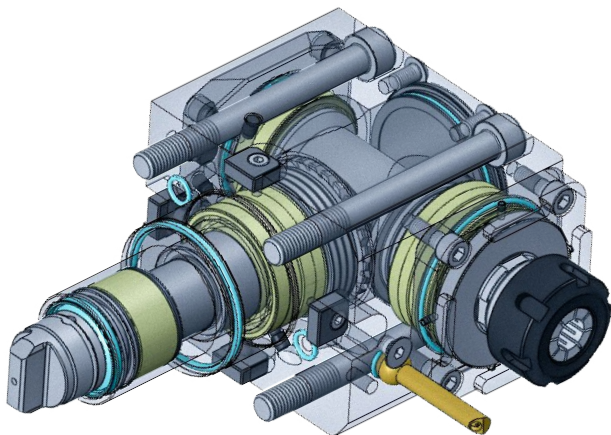

#### **1 - INGRANAGGI GLEASON**

Rettificati e progettati per ottimizzare la coppia in uscita e ridurre le sollecitazioni. Il moto viene trasmesso tramite due chiavette, garantendo affidabilità e precisione. La rettifica migliora la silenziosità di funzionamento grazie all'elevata accuratezza geometrica, mentre l'alta resistenza all'usura rende questi ingranaggi ideali per applicazioni ad alte prestazioni.

#### **2 - ALBERI CEMENTATI**

Gli alberi sono cementati e temprati, con successiva finitura di diametri e battute. La loro struttura è progettata per sopportare carichi elevati e sollecitazioni dinamiche ed è idonea al funzionamento in entrambi i sensi di rotazione. La geometria è studiata per garantire rigidità e stabilità anche in condizioni di lavoro gravose.

#### **3 - TRASMISSIONE DEL MOTO**

Il tenone maggiorato assicura una maggiore stabilità strutturale, riduce le vibrazioni e consente una distribuzione più uniforme delle sollecitazioni meccaniche, migliorando l'affidabilità complessiva del sistema.

#### **4 - USCITA UTENSILE**

L'albero mandrino è disponibile nelle versioni con pinza esterna o interna, oppure con alberi integrali Weldon, portafrese, HSK e altre configurazioni. Le ghiera ER garantiscono elevate prestazioni, assicurando precisione e affidabilità nel serraggio. Il sistema è inoltre predisposto per l'utilizzo del cambio rapido UNI-CHANGE.

#### **5 - CUSCINETTI**

I cuscinetti a sfere a contatto obliquo di alta qualità servono a garantire una rotazione fluida, precisa e ad alta velocità. L'accurata scelta dei componenti assicura prestazioni elevate e affidabilità nel lungo periodo.

#### **6 - CORPO MONOBLOCCO**

Realizzato in acciaio e ottimizzato per la refrigerazione interna ed esterna. È progettato con geometrie e smussi che migliorano l'ergonomia, la maneggevolezza e l'estetica complessiva.

#### **7 - SISTEMA DI PROTEZIONE MANDRINO**

Il sistema di tenuta lato mandrino adotta una configurazione a labirinto, studiata per applicazioni ad alta velocità. Si tratta di una tenuta meccanica senza contatto, basata su una sequenza di gole e camere concentriche che creano un percorso controllato per il refrigerante. In caso di infiltrazioni, la forza centrifuga generata dalla rotazione spinge il liquido verso l'esterno, dove viene espulso tramite appositi fori di drenaggio prima di raggiungere i componenti interni. Questo sistema garantisce un'elevata protezione, riduce la necessità di manutenzione e contribuisce a mantenere stabile la temperatura anche durante cicli di lavoro intensivi.

#### **8 - UGELLI REFRIGERANTE**

Sono progettati per resistere ad alte pressioni e consentono l'installazione di un tappo, permettendo una gestione flessibile e personalizzata del flusso di refrigerante.

#### **9 - CHIAVE MANDRINO**

La chiave mandrino semplifica il cambio utensile: blocca il mandrino in modo sicuro e consente all'operatore di lavorare con entrambe le mani, migliorando ergonomia, sicurezza e rapidità di intervento.

#### **1 - GLEASON GEARS**

Precision-ground Gleason gears are designed to optimize torque output and reduce mechanical stresses. Power transmission is achieved via two keys, ensuring reliability and accuracy. The grinding process enhances quiet operation thanks to precise gear geometry, while the high wear resistance makes these gears ideal for high-performance applications.

#### **2 - CASE HARDENED SHAFTS**

The shafts are case-hardened and hardened, followed by precision finishing of diameters and shoulders. Their structure is engineered to withstand high loads and dynamic stresses and is suitable for operation in both directions of rotation. The geometry ensures rigidity and stability even under heavy-duty operating conditions.

#### **3 - MOTION TRANSMISSION**

The oversized tenon provides increased structural stability, reduced vibrations, and a more uniform distribution of mechanical stresses, improving overall system reliability.

#### **4 - TOOL OUTPUT**

The spindle shaft is available in external or internal collet versions, as well as with integral shanks such as Weldon, end mill holders, HSK, and other configurations. ER nuts ensure high performance, providing precise and reliable clamping. The system is also designed for compatibility with the UNI-CHANGE quick-change system.

#### **5 - BEARINGS**

High-quality angular contact ball bearings are used to ensure smooth, precise, and high-speed rotation. Careful component selection guarantees high performance and long-term reliability.

#### **6 - ONE-PIECE BODY**

The one-piece steel body is optimized for internal and external cooling and features geometries and chamfers designed to enhance ergonomics, handling, and overall aesthetics.

#### **7 - SPINDLE PROTECTION SYSTEM**

The spindle-side sealing system adopts a labyrinth configuration, specifically designed for high-speed applications. This non-contact mechanical seal consists of a sequence of grooves and concentric chambers that create a controlled path for the coolant. In the event of infiltration, the centrifugal force generated by rotation drives the liquid outward, where it is expelled through dedicated drainage holes before reaching internal components. This system ensures excellent protection, reduces maintenance requirements, and helps maintain stable operating temperatures even during intensive duty cycles.

#### **8 - COOLANT NOZZLES**

The coolant nozzles are designed to withstand high pressures and allow the installation of a plug, enabling flexible and customized coolant flow management.

#### **9 - SPINDLE WRENCH**

The spindle wrench simplifies tool changes by securely locking the spindle, allowing the operator to work with both hands free, improving safety, ergonomics, and efficiency.



International  
Haas Automation



VDI 40 - BMT 65



**DOTAZIONE STANDARD**  
STANDARD EQUIPMENT



Chiave bloccaggio albero / chiave per bloccaggio ghiera / ugello refrigerazione / viti bloccaggio motorizzato

Shaft lock wrench / nut lock wrench cooling nozzle Art. 183 / nozzle lock screws / driven tool locking screws

---

**CAMBI RAPIDI MODULARI**  
MODULAR QUICK CHANGE



Facile e veloce sistema modulare per il cambio rapido delle diverse tipologie di portautensili con la sede per pinza ER (DIN6499).

Modular toolholder system for the fitting of toolholders in a spindle unit with ER collets (DIN6499) outputs.

Il valore della coppia, espresso in Nm, è il massimo consentito. Per una maggiore durata, si consiglia di mantenerlo sotto tale soglia  
The torque value, expressed in Nm, is the maximum allowed. For longer life, it is recommended to keep it below this limit

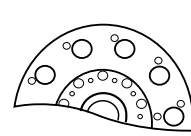
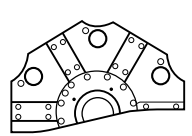
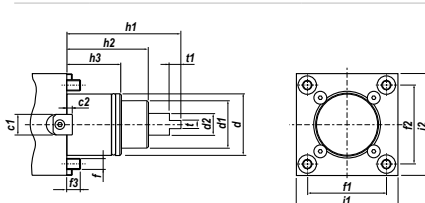
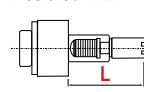
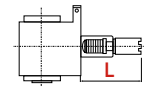
|                                       | VDI   |                 |   |              |              |              | BMT   |           |           |           |     |
|---------------------------------------|---|-----------------|---|--------------|--------------|--------------|---|-----------|-----------|-----------|-----|
| Modello di Torretta<br>Type of Turret | Standard VDI 40   |                 | Ibrida - Hybrid   |              | Haas         |              | DS30Y / ST20Y / ST25Y / ST30Y / ST35Y   |           |           |           |     |
|                                       |  |                 |  |              |              |              |  |           |           |           |     |
| Modello di tornio<br>Type of lathe    | SL20/30   | SL40<br>ST20/30 | SL20/30<br>TL15/25  | SL40         | SL20/30      | SL40         | <b>c1</b>   | 18        | <b>f3</b> | 15        |     |
| Preso di moto<br>Coupling Length      | <b>L</b><br>(mm)  | 104,85          | 117,55  | 117,55       | 130,25       | 117,55       | 130,25  | <b>c2</b> | 5         | <b>h1</b> | 112 |
| <b>Assiale / Axial</b>                |   |                 |   |              |              |              | <b>d</b>  | 65        | <b>h2</b> | 83        |     |
| Code                                  | 99.HA.590083  | 99.HA.590082    | 99.HA.590082  | 99.HA.596352 | 99.HA.590082 | 99.HA.596352 | <b>d1</b>   | 45        | <b>h3</b> | 32        |     |
| <b>Radiale / Radial</b>               |   |                 |   |              |              |              | <b>d2</b>   | 18        | <b>i1</b> | 94        |     |
| Code                                  | 99.HA.590085  | 99.HA.590084    | 99.HA.590084  | 99.HA.596353 | 99.HA.590084 | 99.HA.596353 | <b>f</b>  | M12       | <b>i2</b> | 94        |     |
|                                       |   |                 |   |              |              |              | <b>f1</b>   | 70        | <b>t</b>  | 10        |     |
|                                       |   |                 |   |              |              |              | <b>f2</b>   | 73        | <b>t1</b> | 14        |     |

IN FASE D'ORDINE SPECIFICARE - IN CASE OF ORDER PLEASE SPECIFY:  
costruttore, modello e numero posizioni in torretta - machine builder, model and turret position numbers

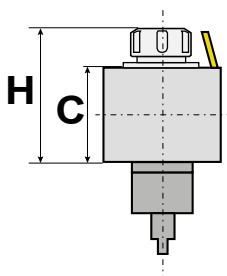
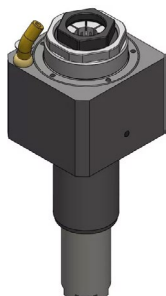
**ASSIALE - AXIAL**

L'asse dell'utensile è in linea all'asse della torretta o del mandrino

The tool axis is aligned to the turret or spindle axis

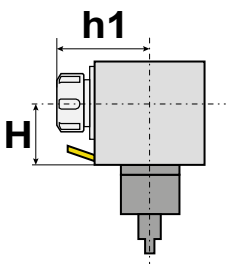
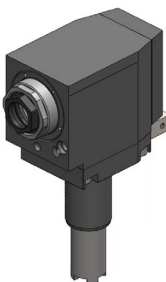
**RADIALE - RADIAL**

L'asse dell'utensile è perpendicolare all'asse della torretta o del mandrino

The tool axis is perpendicular to the turret or spindle axis

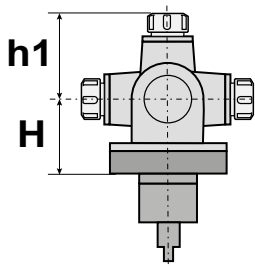
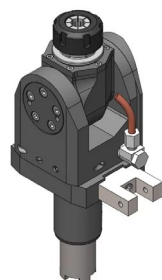
**ORIENTABILE - ADJUSTABLE**

Permettono di inclinare l'asse dell'utensile secondo un angolo specifico richiesto dalla lavorazione

They allow the tool axis to be tilted to a specific angle required for the machining operation

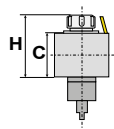

## ASSIALE AXIAL

SCAN IT TO SEE



THE TECHNICAL SHEETS

| Code          | Output      | Int Cool. | L      | H  | C  | Nm | Ratio | Rpm   | Kg | Sense of Rotation | Tech. Draw |
|---------------|-------------|-----------|--------|----|----|----|-------|-------|----|-------------------|------------|
| 99.HA.590082  | ER-32 Ø2+20 | -         | 117.55 | 75 | 57 | 30 | 1 : 1 | 6.000 | 3  |                   | ↓          |
| 99.HA.590082B | ER-32 Ø2+20 | • 25 bar  |        | 75 | 57 | 63 | 1 : 1 | 6.000 | 10 |                   | ↓          |
| 99.HA.590083  | ER-32 Ø2+20 | -         | 104.85 | 75 | 57 | 30 | 1 : 1 | 6.000 | 3  |                   | ↓          |
| 99.HA.590083B | ER-32 Ø2+20 | • 25 bar  |        | 75 | 57 | 63 | 1 : 1 | 6.000 | 10 |                   | ↓          |
| 99.HA.596352  | ER-32 Ø2+20 | -         | 130.25 | 75 | 57 | 30 | 1 : 1 | 6.000 | 3  |                   | ↓          |
| 99.HA.596352B | ER-32 Ø2+20 | • 25 bar  |        | 75 | 57 | 63 | 1 : 1 | 6.000 | 10 |                   | ↓          |

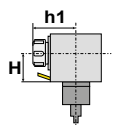

## RADIALE RADIAL

| Code          | Output      | Int Cool. | L      | H  | h1   | Nm | Ratio | Rpm   | Kg | Sense of Rotation | Tech. Draw |
|---------------|-------------|-----------|--------|----|------|----|-------|-------|----|-------------------|------------|
| 99.HA.590084  | ER-32 Ø2+20 | -         | 117.55 | 75 | 86,6 | 30 | 1 : 1 | 6.000 | 7  |                   | ↓          |
| 99.HA.590084B | ER-32 Ø2+20 | • 25 bar  |        | 75 | 86,6 | 30 | 1 : 1 | 6.000 | 7  |                   | ↓          |
| 99.HA.590085  | ER-32 Ø2+20 | -         | 104.85 | 75 | 86,6 | 63 | 1 : 1 | 6.000 |    |                   | ↓          |
| 99.HA.590085B | ER-32 Ø2+20 | • 25 bar  |        | 75 | 86,6 | 63 | 1 : 1 | 6.000 | 10 |                   | ↓          |
| 99.HA.596353  | ER-32 Ø2+20 | -         | 130.25 | 75 | 86,6 | 63 | 1 : 1 | 6.000 |    |                   | ↓          |
| 99.HA.596353B | ER-32 Ø2+20 | • 80 bar  |        | 75 | 86,6 | 63 | 1 : 1 | 6.000 |    |                   | ↓          |

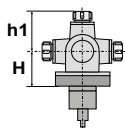

## ORIENTABILE ADJUSTABLE

| Code        | Output      | Int Cool. | L      | H  | h1   | Nm | Ratio | Rpm   | Kg | Sense of Rotation | Tech. Draw |
|-------------|-------------|-----------|--------|----|------|----|-------|-------|----|-------------------|------------|
| 99.HA.00U1  | ER-25 Ø1+16 | -         | 104.85 | 81 | 69,3 | 25 | 1 : 1 | 6.000 | 5  |                   | ↓          |
| 99.HA.00U2  | ER-25 Ø1+16 | -         | 117.55 | 81 | 69,3 | 25 | 1 : 1 | 6.000 | 6  |                   | ↓          |
| 99.HA.00U2B | ER-25 Ø1+16 | • 25 bar  |        | 83 | 69,3 | 25 | 1 : 1 | 6.000 | 10 |                   | ↓          |

**MODELLI DI TORNIO COMPATIBILI**  
 COMPATIBLE LATHE TYPES

Haas

Vedi pagine compatibilità 5.14 / 5.20 - See compatibility pages 5.14 / 5.20

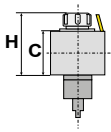

**ASSIALE**  
**AXIAL**

SCAN IT TO SEE

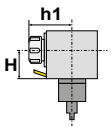

THE TECHNICAL SHEETS

| Code       | Output      | Int Cool. | H    | C  | Nm | Ratio | Rpm   | Kg | Sense of Rotation | Tech. Draw |
|------------|-------------|-----------|------|----|----|-------|-------|----|-------------------|------------|
| 99.DS.A41  | ER-32 Ø2+20 | -         | 72.2 | 32 | 70 | 1 : 1 | 6.000 | 10 |                   |            |
| 99.DS.A42  | ER-32 Ø2+20 | • 80 bar  | 72.2 | 32 | 50 | 1 : 1 | 6.000 | 4  |                   |            |
| 99.DS.A137 | ER-16 Ø1+10 | • 80 bar  | 66   | 32 | 40 | 1 : 1 | 6.000 | 3  |                   |            |

**RADIALE**  
**RADIAL**

| Code        | Output      | Int Cool. | H   | h1    | Nm | Ratio | Rpm    | Kg | Sense of Rotation | Tech. Draw |
|-------------|-------------|-----------|-----|-------|----|-------|--------|----|-------------------|------------|
| 99.DS.A51   | ER-32 Ø2+20 | -         | 72  | 93,6  | 70 | 1 : 1 | 6.000  | 10 |                   |            |
| 99.DS.A51C  | ER-32 Ø2+20 | -         | 72  | 93,6  | 70 | 1 : 1 | 6.000  | 10 |                   |            |
| 99.DS.A52   | ER-32 Ø2+20 | • 80 bar  | 72  | 93,6  | 70 | 1 : 1 | 6.000  | 10 |                   |            |
| 99.DS.A52C  | ER-32 Ø2+20 | • 80 bar  | 72  | 93,6  | 70 | 1 : 1 | 6.000  | 10 |                   |            |
| 99.DS.A73   | ER-32 Ø2+20 | -         | 100 | 93,6  | 70 | 1 : 1 | 6.000  | 10 |                   |            |
| 99.DS.A73C  | ER-32 Ø2+20 | -         | 100 | 93,6  | 70 | 1 : 1 | 6.000  | 10 |                   |            |
| 99.DS.A74   | ER-32 Ø2+20 | • 80 bar  | 100 | 93,6  | 70 | 1 : 1 | 6.000  | 10 |                   |            |
| 99.DS.A74C  | ER-32 Ø2+20 | • 80 bar  | 100 | 93,6  | 70 | 1 : 1 | 6.000  | 10 |                   |            |
| 99.DS.A30   | ER-20 Ø1+13 | -         | 72  | 93,6  | 12 | 1 : 4 | 12.000 | 7  |                   |            |
| 99.DS.A62   | PF-22 Ø22   | -         | 72  | 103,5 | 70 | 1 : 1 | 6.000  | 10 |                   |            |
| 99.DS.A62C  | PF-22 Ø22   | -         | 72  | 103,5 | 70 | 1 : 1 | 6.000  | 10 |                   |            |
| 99.DS.A111  | PF-22 Ø22   | -         | 100 | 103,5 | 70 | 1 : 1 | 6.000  | 10 |                   |            |
| 99.DS.A111C | PF-22 Ø22   | -         | 100 | 103,5 | 70 | 1 : 1 | 6.000  | 10 |                   |            |

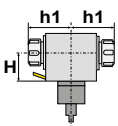
**RADIALE DOPPIO**  
**RADIAL DOUBLE**

| Code      | Output                         | Int Cool. | H   | h1   | Nm | Ratio | Rpm   | Kg | Sense of Rotation | Tech. Draw |
|-----------|--------------------------------|-----------|-----|------|----|-------|-------|----|-------------------|------------|
| 99.DS.A31 | ER-32 / Ø2+20 /<br>ER-32 Ø2+20 | -         | 72  | 93,6 | 70 | 1 : 1 | 6.000 | 10 |                   |            |
| 99.DS.A78 | ER-32 / Ø2+20 /<br>ER-32 Ø2+20 | -         | 100 | 93,6 | 70 | 1 : 1 | 6.000 | 10 |                   |            |

**ER** Portapinzina  
Collet Holder

**PF** Portafresa  
Shell Mill Holder

 Ugualo al Mandrino  
Same as Spindle

 Opposto al Mandrino  
Opposite as Spindle

 Refrigerante Interno  
Internal Coolant

 Scarica il PDF  
PDF Download

SCAN IT TO SEE



THE TECHNICAL SHEETS

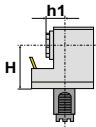

## RADIALE ARRETRATO RADIAL OFFSET

| Code       | Output | Int Cool. | H | h1  | Nm   | Ratio | Rpm   | Kg    | Sense of Rotation | Tech. Draw |   |
|------------|--------|-----------|---|-----|------|-------|-------|-------|-------------------|------------|---|
| 99.DS.A125 | ER-32  | Ø2÷20     | - | 100 | 53,4 | 40    | 1 : 1 | 6.000 | 12                | ↻          | ↓ |

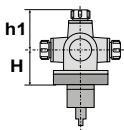

## ORIENTABILE ADJUSTABLE

| Code      | Output | Int Cool. | H        | h1 | Nm   | Ratio | Rpm   | Kg    | Sense of Rotation | Tech. Draw |   |
|-----------|--------|-----------|----------|----|------|-------|-------|-------|-------------------|------------|---|
| 99.DS.A64 | ER-25  | Ø1÷16     | -        | 75 | 67,2 | 25    | 1 : 1 | 6.000 | 5                 | ↻          | ↓ |
| 99.DS.A65 | ER-25  | Ø1÷16     | • 80 bar | 75 | 67,2 | 25    | 1 : 1 | 6.000 | 5                 | ↻          | ↓ |

## ACCESSORI HAAS

### HAAS ACCESSORIES

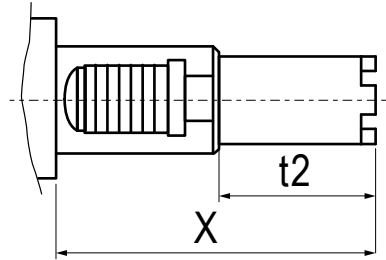

**Presse di moto intercambiabile per le varie tipologie di torrette HAAS**  
 Interchangeable couplings for the different HAAS turret

| Code        | t2    | X      | €          |
|-------------|-------|--------|------------|
| 99.HA.00001 | 41,85 | 104,85 | <b>109</b> |
| 99.HA.00002 | 54,55 | 117,55 | <b>109</b> |
| 99.HA.00003 | 67,25 | 130,25 | <b>109</b> |

QTN 1/2/3 - QTS 1 - HQ

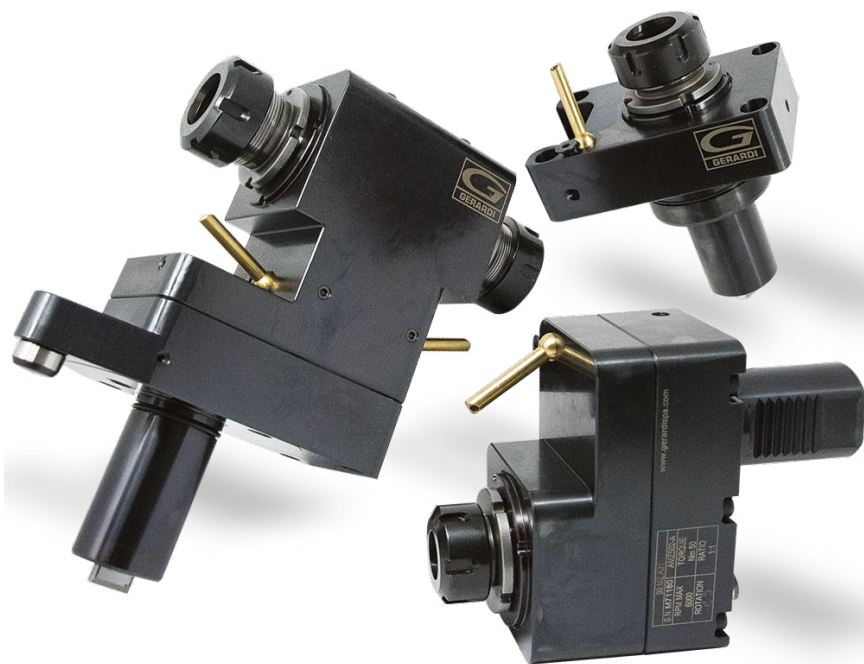

**USCITA C. ISO26623**  
C. ISO26623 OUTPUT

Disponibile su richiesta  
Available on request



**DOTAZIONE STANDARD**  
STANDARD EQUIPMENT

Chiave bloccaggio albero / chiave per bloccaggio ghiera / ugello refrigerazione / viti bloccaggio motorizzato

Shaft lock wrench / nut lock wrench cooling nozzle Art.183 / nozzle lock screws / driven tool locking screws



**CAMBI RAPIDI MODULARI**  
MODULAR QUICK CHANGE

Facile e veloce sistema modulare per il cambio rapido delle diverse tipologie di portautensili con la sede per pinza ER (DIN6499).

Modular toolholder system for the fitting of toolholders in a spindle unit with ER collets (DIN6499) outputs.

Il valore della coppia, espresso in Nm, è il massimo consentito. Per una maggiore durata, si consiglia di mantenerlo sotto tale soglia  
The torque value, expressed in Nm, is the maximum allowed. For longer life, it is recommended to keep it below this limit

| TYPE | D2  | H1 | H3 | T  | f   | f3  |
|------|-----|----|----|----|-----|-----|
| QTN1 | Ø40 | 61 | 1  | 10 | -   | -   |
| QTN2 | Ø40 | 70 | 8  | 18 | -   | -   |
| QTN3 | Ø50 | 75 | 10 | 12 | -   | -   |
| QTS  | Ø40 | 90 | 10 | 12 | -   | -   |
| HQ   | Ø40 | 60 | 8  | 10 | Ø20 | 9,8 |

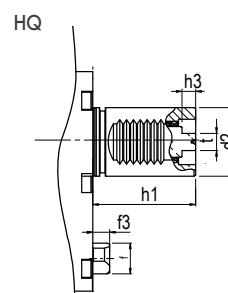
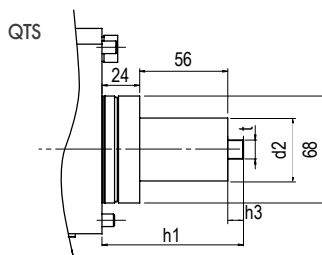
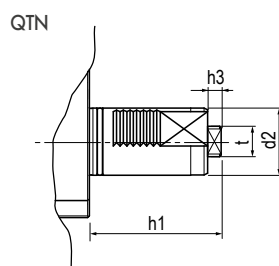

IN FASE D'ORDINE SPECIFICARE - IN CASE OF ORDER PLEASE SPECIFY:  
costruttore, modello e numero posizioni in torretta - machine builder, model and turret position numbers

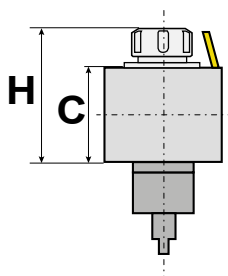
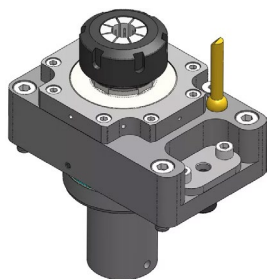
**ASSIALE - AXIAL**

L'asse dell'utensile è in linea all'asse della torretta o del mandrino

The tool axis is aligned to the turret or spindle axis

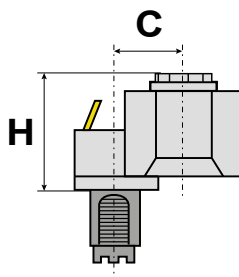
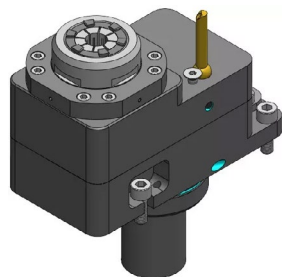
**ASSIALE DISASSATO - OFFSET AXIS**

L'asse dell'utensile è in linea ma traslato rispetto all'asse della torretta

The tool axis is aligned with, but offset from, the turret axis

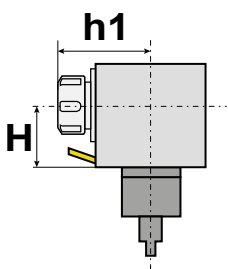
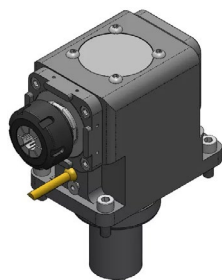
**RADIALE - RADIAL**

L'asse dell'utensile è perpendicolare all'asse della torretta o del mandrino

The tool axis is perpendicular to the turret or spindle axis

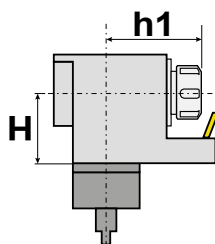
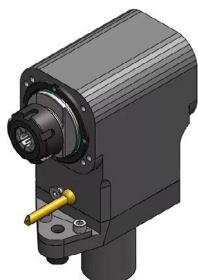
**RADIALE ROVESCiato - RADIAL UPSIDE DOWN**

L'asse dell'utensile è perpendicolare all'asse della torretta o del mandrino ma con il tagliente rivolto in direzione opposta

The tool axis is perpendicular to the axis of the turret or spindle, but with the cutting edge facing in the opposite direction

## RADIALE DOPPIO - DOUBLE RADIAL

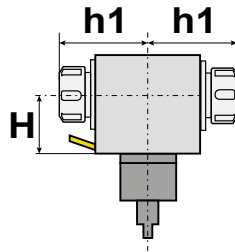
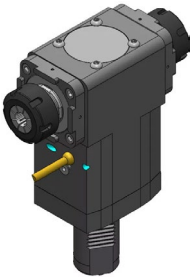

Il motorizzato ha due uscite situate sullo stesso asse radiale, ma rivolte in direzioni opposte

The driven tool has two outputs situated on the same radial axis, but facing in opposite directions

## RADIALE ARRETRATO - RADIAL REAR OFFSET

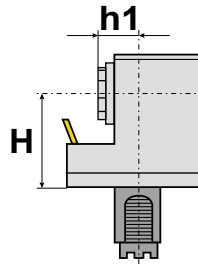

L'asse dell'utensile è perpendicolare all'asse della torretta o del mandrino ma traslato verso il corpo del motorizzato

The tool axis is perpendicular to the axis of the turret or spindle but offset towards the motorised unit

## RADIALE DOPPIO ARRETRATO - RADIAL DOUBLE OFFSET

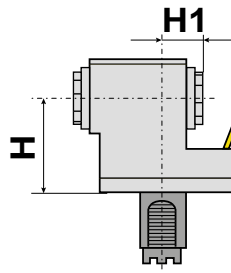
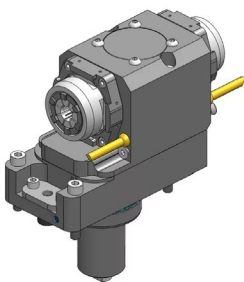

Le due uscite sono spostate all'indietro rispetto all'asse centrale del gambo

The two outputs are set back from the central axis of the stem

## ORIENTABILE - ADJUSTABLE

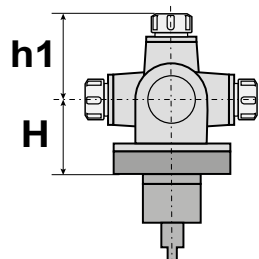

Permettono di inclinare l'asse dell'utensile secondo un angolo specifico richiesto dalla lavorazione

They allow the tool axis to be tilted to a specific angle required for the machining operation

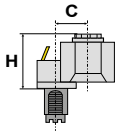

## ASSIALE DISASSATO AXIAL OFFSET

| Code      | Output      | Int Cool. | H   | C   | Nm | Ratio | Rpm   | Kg | Sense of Rotation | Tech. Draw |
|-----------|-------------|-----------|-----|-----|----|-------|-------|----|-------------------|------------|
| 99.MZ.A40 | ER-25 Ø1+16 | -         | 120 | 107 | 30 | 1 : 1 | 6.000 | 20 |                   |            |
| 99.MZ.A41 | ER-25 Ø1+16 | • 80 bar  | 120 | 107 | 30 | 1 : 1 | 6.000 | 6  |                   |            |

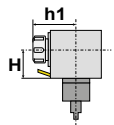

## RADIALE RADIAL

| Code      | Output      | Int Cool. | H   | h1   | Nm | Ratio | Rpm   | Kg | Sense of Rotation | Tech. Draw |
|-----------|-------------|-----------|-----|------|----|-------|-------|----|-------------------|------------|
| 99.MZ.A46 | ER-25 Ø1+16 | -         | 100 | 93,8 | 50 | 1 : 1 | 6.000 |    |                   |            |
| 99.MZ.A47 | ER-25 Ø1+16 | • 80 bar  | 100 | 93,8 | 30 | 1 : 1 | 6.000 | 8  |                   |            |

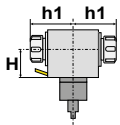

## RADIALE DOPPIO RADIAL DOUBLE

| Code      | Output                         | Int Cool. | H   | h1   | Nm | Ratio | Rpm   | Kg | Sense of Rotation | Tech. Draw |
|-----------|--------------------------------|-----------|-----|------|----|-------|-------|----|-------------------|------------|
| 99.MZ.A55 | ER-25 / Ø1+16 /<br>ER-25 Ø1+16 | -         | 100 | 93,8 | 30 | 1 : 1 | 6.000 | 7  |                   |            |

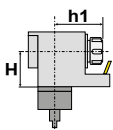

## RADIALE ROVESCiato RADIAL UPSIDE DOWN

| Code      | Output      | Int Cool. | H   | h1   | Nm | Ratio | Rpm   | Kg | Sense of Rotation | Tech. Draw |
|-----------|-------------|-----------|-----|------|----|-------|-------|----|-------------------|------------|
| 99.MZ.A48 | ER-25 Ø1+16 | -         | 100 | 93,8 | 30 | 1 : 1 | 6.000 | 20 |                   |            |
| 99.MZ.A49 | ER-25 Ø1+16 | • 80 bar  | 100 | 93,8 | 63 | 1 : 1 | 6.000 |    |                   |            |

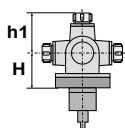

## ORIENTABILE ADJUSTABLE

| Code      | Output      | Int Cool. | H  | h1   | Nm | Ratio | Rpm   | Kg | Sense of Rotation | Tech. Draw |
|-----------|-------------|-----------|----|------|----|-------|-------|----|-------------------|------------|
| 99.MZ.A56 | ER-20 Ø1+13 | -         | 81 | 67,5 | 25 | 1 : 1 | 6.000 | 5  |                   |            |

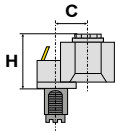

## ASSIALE DISASSATO AXIAL OFFSET

| Code      | Output      | Int Cool. | H   | C  | Nm | Ratio | Rpm   | Kg | Sense of Rotation | Tech. Draw |
|-----------|-------------|-----------|-----|----|----|-------|-------|----|-------------------|------------|
| 99.MZ.A58 | ER-32 Ø2+20 | -         | 120 | 50 | 30 | 1 : 1 | 6.000 | 6  |                   | ↓          |
| 99.MZ.A59 | ER-32 Ø2+20 | • 80 bar  | 120 | 50 | 80 | 1 : 1 | 6.000 |    |                   | ↓          |
| 99.MZ.A69 | PF-22 Ø22   | -         |     |    | 30 | 1 : 1 | 6.000 | 7  |                   | ↓          |

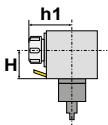

## RADIALE RADIAL

| Code      | Output      | Int Cool. | H   | h1   | Nm | Ratio | Rpm   | Kg | Sense of Rotation | Tech. Draw |
|-----------|-------------|-----------|-----|------|----|-------|-------|----|-------------------|------------|
| 99.MZ.A65 | ER-32 Ø2+20 | -         | 130 | 93,8 | 80 | 1 : 1 | 6.000 |    |                   | ↓          |
| 99.MZ.A66 | ER-32 Ø2+20 | • 80 bar  | 130 | 93,8 | 80 | 1 : 1 | 6.000 |    |                   | ↓          |
| 99.MZ.A62 | PF-22 Ø22   | -         | 130 | 103  | 80 | 1 : 1 | 6.000 |    |                   | ↓          |

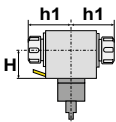

## RADIALE DOPPIO RADIAL DOUBLE

| Code      | Output                         | Int Cool. | H   | h1   | Nm | Ratio | Rpm   | Kg | Sense of Rotation | Tech. Draw |
|-----------|--------------------------------|-----------|-----|------|----|-------|-------|----|-------------------|------------|
| 99.MZ.A73 | ER-32 / Ø2+20 /<br>ER-32 Ø2+20 | -         | 130 | 93,8 | 80 | 1 : 1 | 6.000 |    |                   | ↓          |

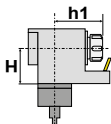

## RADIALE ROVESCiato RADIAL UPSIDE DOWN

| Code      | Output      | Int Cool. | H   | h1   | Nm | Ratio | Rpm   | Kg | Sense of Rotation | Tech. Draw |
|-----------|-------------|-----------|-----|------|----|-------|-------|----|-------------------|------------|
| 99.MZ.A67 | ER-32 Ø2+20 | -         | 130 | 93,8 | 80 | 1 : 1 | 6.000 |    |                   | ↓          |
| 99.MZ.A68 | ER-32 Ø2+20 | • 80 bar  | 130 | 93,8 | 80 | 1 : 1 | 6.000 |    |                   | ↓          |
| 99.MZ.A63 | PF-22 Ø22   | -         | 130 | 53   | 80 | 1 : 1 | 6.000 |    |                   | ↓          |

MODELLI DI TORNIO COMPATIBILI  
 COMPATIBLE LATHE TYPES

Mazak

Vedi pagine compatibilità 5.14 / 5.20 - See compatibility pages 5.14 / 5.20

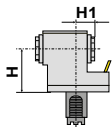

## RADIALE DOPPIO ARRETRATO

### RADIAL DOUBLE OFFSET

SCAN IT TO SEE



THE TECHNICAL SHEETS

| Code      | Output                         | Int Cool. | H   | h1   | Nm | Ratio | Rpm   | Kg | Sense of Rotation | Tech. Draw |
|-----------|--------------------------------|-----------|-----|------|----|-------|-------|----|-------------------|------------|
| 99.MZ.A70 | ER-32 / Ø2+20 /<br>ER-32 Ø2+20 | -         | 130 | 93,8 | 30 | 1 : 1 | 6.000 | 10 |                   |            |

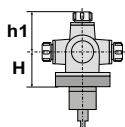

## ORIENTABILE

### ADJUSTABLE

| Code      | Output      | Int Cool. | H  | h1 | Nm | Ratio | Rpm   | Kg | Sense of Rotation | Tech. Draw |
|-----------|-------------|-----------|----|----|----|-------|-------|----|-------------------|------------|
| 99.MZ.A74 | ER-25 Ø1+16 | -         | 85 |    | 80 | 1 : 1 | 6.000 |    |                   |            |
| 99.MZ.A64 | ER-25 Ø1+16 | • 80 bar  | 85 |    | 80 | 1 : 1 | 6.000 |    |                   |            |

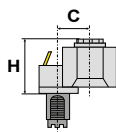

## ASSIALE DISASSATO AXIAL OFFSET

| Code      | Output      | Int Cool. | H    | C  | Nm | Ratio | Rpm   | Kg | Sense of Rotation | Tech. Draw        |
|-----------|-------------|-----------|------|----|----|-------|-------|----|-------------------|-------------------|
| 99.MZ.A71 | ER-40 Ø3+30 | -         | 145  | 75 | 70 | 1 : 1 | 4.000 | 12 |                   | <a href="#">↓</a> |
| 99.MZ.A72 | ER-40 Ø3+30 | • 80 bar  | 145  | 75 | 70 | 1 : 1 | 4.000 | 13 |                   | <a href="#">↓</a> |
| 99.MZ.A76 | ISO-40      | -         | 92.5 | 75 | 70 | 1 : 1 | 4.000 | 12 |                   | <a href="#">↓</a> |
| 99.MZ.A79 | ISO-40      | • 80 bar  | 125  | 75 | 70 | 1 : 1 | 4.000 | 12 |                   | <a href="#">↓</a> |

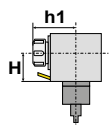

## RADIALE RADIAL

| Code      | Output      | Int Cool. | H   | h1 | Nm  | Ratio | Rpm   | Kg | Sense of Rotation | Tech. Draw        |
|-----------|-------------|-----------|-----|----|-----|-------|-------|----|-------------------|-------------------|
| 99.MZ.A75 | ER-40 Ø3+30 | -         | 160 |    | 100 | 1 : 1 | 4.000 |    |                   | <a href="#">↓</a> |
| 99.MZ.A81 | ER-40 Ø3+30 | • 80 bar  | 160 |    | 100 | 1 : 1 | 4.000 |    |                   | <a href="#">↓</a> |
| 99.MZ.A77 | ISO-40      | -         | 160 | 73 | 70  | 1 : 1 | 4.000 | 7  |                   | <a href="#">↓</a> |
| 99.MZ.A78 | ISO-40      | • 80 bar  | 160 | 73 | 70  | 1 : 1 | 4.000 | 17 |                   | <a href="#">↓</a> |

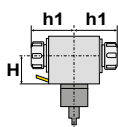

## RADIALE DOPPIO RADIAL DOUBLE

| Code      | Output                         | Int Cool. | H   | h1 | Nm  | Ratio | Rpm   | Kg | Sense of Rotation | Tech. Draw        |
|-----------|--------------------------------|-----------|-----|----|-----|-------|-------|----|-------------------|-------------------|
| 99.MZ.A84 | ER-40 / Ø3+30 /<br>ER-40 Ø3+30 | -         | 160 |    | 100 | 1 : 1 | 4.000 |    |                   | <a href="#">↓</a> |

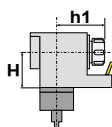

## RADIALE ROVESCiato RADIAL UPSIDE DOWN

| Code      | Output      | Int Cool. | H   | h1 | Nm  | Ratio | Rpm   | Kg | Sense of Rotation | Tech. Draw        |
|-----------|-------------|-----------|-----|----|-----|-------|-------|----|-------------------|-------------------|
| 99.MZ.A82 | ER-40 Ø3+30 | -         | 160 |    | 100 | 1 : 1 | 4.000 |    |                   | <a href="#">↓</a> |

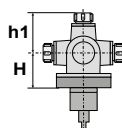

## ORIENTABILE ADJUSTABLE

| Code      | Output      | Int Cool. | H  | h1   | Nm | Ratio | Rpm   | Kg | Sense of Rotation | Tech. Draw        |
|-----------|-------------|-----------|----|------|----|-------|-------|----|-------------------|-------------------|
| 99.MZ.A80 | ER-32 Ø2+20 | -         | 85 | 67,5 | 20 | 1 : 1 | 6.000 | 11 |                   | <a href="#">↓</a> |

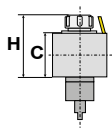

## ASSIALE AXIAL



THE TECHNICAL SHEETS

| Code      | Output      | Int Cool. | H  | C  | Nm | Ratio | Rpm   | Kg | Sense of Rotation | Tech. Draw |
|-----------|-------------|-----------|----|----|----|-------|-------|----|-------------------|------------|
| 99.MZ.A03 | ER-32 Ø2+20 | -         | 70 | 30 | 60 | 1 : 1 | 6.000 |    |                   |            |
| 99.MZ.A06 | ER-32 Ø2+20 | • 80 bar  | 70 | 30 | 60 | 1 : 1 | 6.000 |    |                   |            |

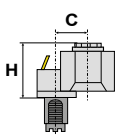

## ASSIALE DISASSATO AXIAL OFFSET

| Code      | Output      | Int Cool. | H     | C    | Nm | Ratio | Rpm   | Kg | Sense of Rotation | Tech. Draw |
|-----------|-------------|-----------|-------|------|----|-------|-------|----|-------------------|------------|
| 99.MZ.A04 | ER-32 Ø2+20 | -         | 113.5 | 71,5 | 60 | 1 : 1 | 6.000 |    |                   |            |
| 99.MZ.A05 | ER-32 Ø2+20 | • 80 bar  | 113.5 | 71,5 | 60 | 1 : 1 | 6.000 |    |                   |            |

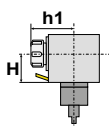

## RADIALE RADIAL

| Code      | Output      | Int Cool. | H  | h1   | Nm | Ratio | Rpm   | Kg | Sense of Rotation | Tech. Draw |
|-----------|-------------|-----------|----|------|----|-------|-------|----|-------------------|------------|
| 99.MZ.A09 | ER-32 Ø2+20 | -         | 80 | 50,5 | 60 | 1 : 1 | 6.000 |    |                   |            |
| 99.MZ.A10 | ER-32 Ø2+20 | • 80 bar  | 80 | 63   | 60 | 1 : 1 | 6.000 |    |                   |            |

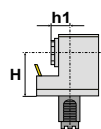

## RADIALE ARRETRATO RADIAL OFFSET

| Code      | Output      | Int Cool. | H  | h1   | Nm | Ratio | Rpm   | Kg | Sense of Rotation | Tech. Draw |
|-----------|-------------|-----------|----|------|----|-------|-------|----|-------------------|------------|
| 99.MZ.A17 | ER-32 Ø2+20 | -         | 85 | 38,4 | 60 | 1 : 1 | 6.000 | 11 |                   |            |
| 99.MZ.A18 | ER-32 Ø2+20 | • 80 bar  | 85 | 38,4 | 60 | 1 : 1 | 6.000 | 11 |                   |            |

SCAN IT TO SEE



THE TECHNICAL SHEETS

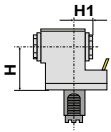

## RADIALE DOPPIO ARRETRATO

### RADIAL DOUBLE OFFSET

| Code      | Output                         | Int Cool. | H  | h1   | Nm | Ratio | Rpm   | Kg | Sense of Rotation | Tech. Draw |
|-----------|--------------------------------|-----------|----|------|----|-------|-------|----|-------------------|------------|
| 99.MZ.A13 | ER-32 / Ø2+20 /<br>ER-32 Ø2+20 | -         | 85 | 38,4 | 60 | 1 : 1 | 6.000 |    |                   | ↓          |

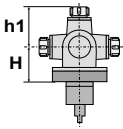

## ORIENTABILE

### ADJUSTABLE

| Code      | Output      | Int Cool. | H  | h1   | Nm | Ratio | Rpm   | Kg | Sense of Rotation | Tech. Draw |
|-----------|-------------|-----------|----|------|----|-------|-------|----|-------------------|------------|
| 99.MZ.A14 | ER-25 Ø1+16 | -         | 80 | 67,2 | 30 | 1 : 1 | 6.000 | 6  |                   | ↓          |
| 99.MZ.A15 | ER-25 Ø1+16 | • 80 bar  | 80 | 67,2 | 30 | 1 : 1 | 6.000 | 6  |                   | ↓          |

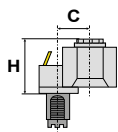

## ASSIALE DISASSATO AXIAL OFFSET

| Code      | Output      | Int Cool. | H   | C  | Nm | Ratio | Rpm   | Kg | Sense of Rotation | Tech. Draw |
|-----------|-------------|-----------|-----|----|----|-------|-------|----|-------------------|------------|
| 99.MZ.A30 | ER-25 Ø1+16 | -         | 116 | 50 | 50 | 1 : 1 | 6.000 |    |                   |            |
| 99.MZ.A31 | ER-25 Ø1+16 | • 80 bar  | 116 | 50 | 50 | 1 : 1 | 6.000 |    |                   |            |

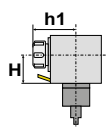

## RADIALE RADIAL

| Code      | Output      | Int Cool. | H   | h1   | Nm | Ratio | Rpm   | Kg | Sense of Rotation | Tech. Draw |
|-----------|-------------|-----------|-----|------|----|-------|-------|----|-------------------|------------|
| 99.MZ.A36 | ER-25 Ø1+16 | -         | 115 | 87,5 | 50 | 1 : 1 | 6.000 |    |                   |            |
| 99.MZ.A37 | ER-25 Ø1+16 | • 80 bar  | 115 | 87,5 | 30 | 1 : 1 | 6.000 | 9  |                   |            |

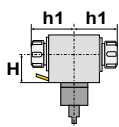

## RADIALE DOPPIO RADIAL DOUBLE

| Code      | Output      | Int Cool. | H   | h1   | Nm | Ratio | Rpm   | Kg | Sense of Rotation | Tech. Draw |
|-----------|-------------|-----------|-----|------|----|-------|-------|----|-------------------|------------|
| 99.MZ.A35 | ER-25 Ø1+16 | -         | 115 | 87,5 | 50 | 1 : 1 | 6.000 |    |                   |            |

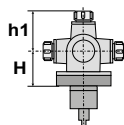

## ORIENTABILE ADJUSTABLE

| Code      | Output      | Int Cool. | H  | h1   | Nm | Ratio | Rpm   | Kg | Sense of Rotation | Tech. Draw |
|-----------|-------------|-----------|----|------|----|-------|-------|----|-------------------|------------|
| 99.MZ.A38 | ER-20 Ø1+13 | • 80 bar  | 65 | 67,2 | 15 | 1 : 1 | 6.000 | 3  |                   |            |

Ø38 / Ø45 / Ø54

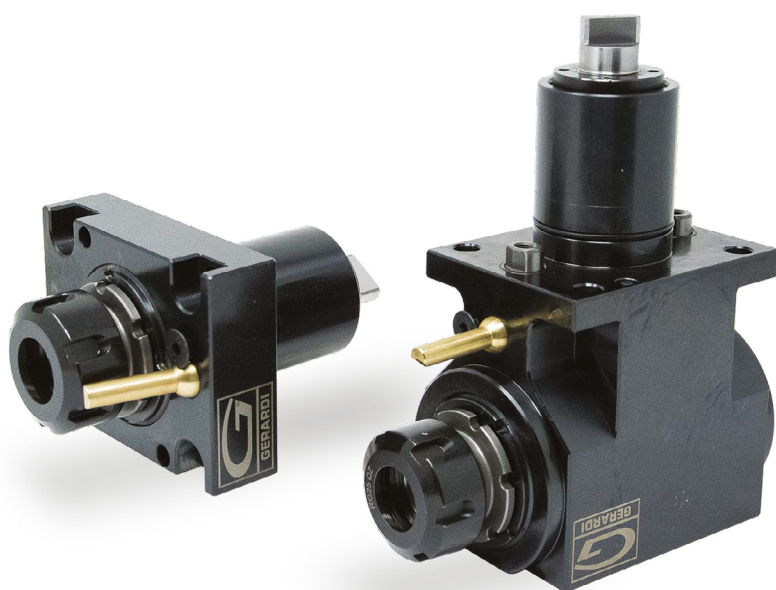

### DOTAZIONE STANDARD STANDARD EQUIPMENT



Chiave bloccaggio albero / chiave per bloccaggio ghiera / ugello refrigerazione / viti bloccaggio motorizzato

Shaft lock wrench / nut lock wrench cooling nozzle Art.183 / nozzle lock screws / driven tool locking screws

### CAMBI RAPIDI MODULARI MODULAR QUICK CHANGE



Facile e veloce sistema modulare per il cambio rapido delle diverse tipologie di portautensili con la sede per pinza ER (DIN6499).

Modular toolholder system for the fitting of toolholders in a spindle unit with ER collets (DIN6499) outputs.

**Il valore della coppia, espresso in Nm, è il massimo consentito. Per una maggiore durata, si consiglia di mantenerlo sotto tale soglia**  
The torque value, expressed in Nm, is the maximum allowed. For longer life, it is recommended to keep it below this limit

| Type | d  | d1 | d2 | f  | f1 | f2 | f3 | h1 | h2 | h3 | i1 | i2  | t  | t1  |
|------|----|----|----|----|----|----|----|----|----|----|----|-----|----|-----|
| Ø38  | 38 | -  | -  | M6 | 52 | 56 | 7  | 37 | -  | 30 | 78 | 78  | 6  | 7   |
| Ø45  | 45 | 35 | 19 | M8 | 56 | 68 | 10 | 76 | 59 | 55 | 92 | 70  | 12 | 8,5 |
| Ø54  | 54 | -  | 24 | M8 | 75 | 60 | 10 | 72 | 50 | 40 | 90 | 100 | 8  | 12  |

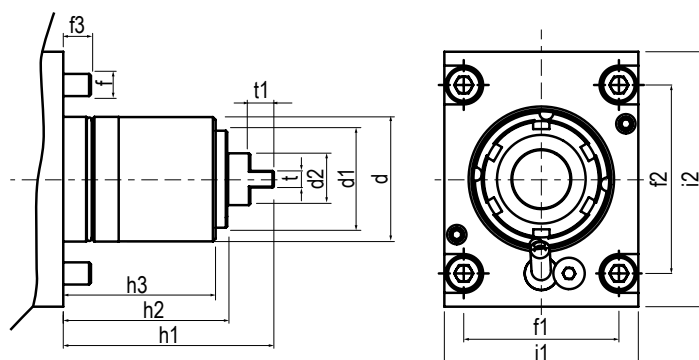

IN FASE D'ORDINE SPECIFICARE - IN CASE OF ORDER PLEASE SPECIFY:  
costruttore, modello e numero posizioni in torretta - machine builder, model and turret position numbers

## ASSIALE - AXIAL

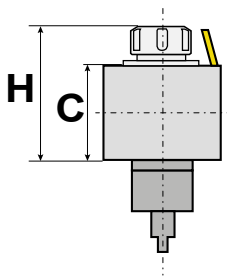
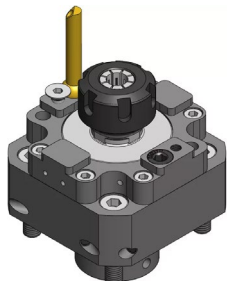

L'asse dell'utensile è in linea all'asse della torretta o del mandrino

The tool axis is aligned to the turret or spindle axis

## RADIALE - RADIAL

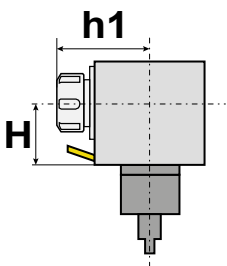
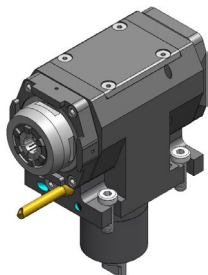

L'asse dell'utensile è perpendicolare all'asse della torretta o del mandrino

The tool axis is perpendicular to the turret or spindle axis

## RADIALE DOPPIO ARRETRATO - RADIAL DOUBLE OFFSET

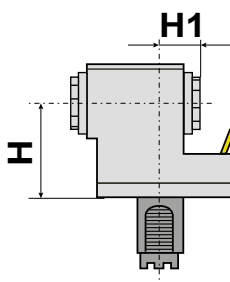
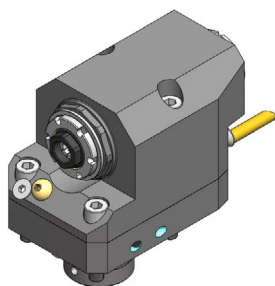

Le due uscite sono spostate all'indietro rispetto all'asse centrale del gambo

The two outputs are set back from the central axis of the stem

## RADIALE DOPPIO - DOUBLE RADIAL

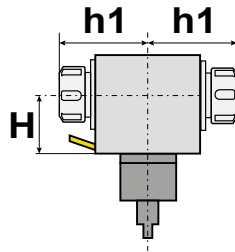
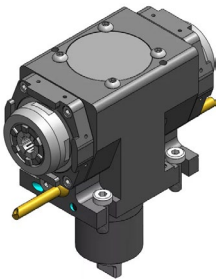

**Il motorizzato ha due uscite situate sullo stesso asse radiale, ma rivolte in direzioni opposte**

The driven tool has two outputs situated on the same radial axis, but facing in opposite directions

## ORIENTABILE - ADJUSTABLE

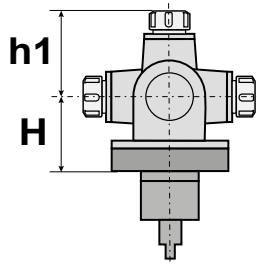
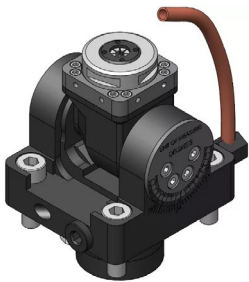

**Permettono di inclinare l'asse dell'utensile secondo un angolo specifico richiesto dalla lavorazione**

They allow the tool axis to be tilted to a specific angle required for the machining operation

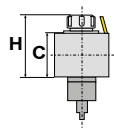

## ASSIALE AXIAL

SCAN IT TO SEE



THE TECHNICAL SHEETS

| Code      | Output      | Int Cool. | H    | C  | Nm | Ratio | Rpm   | Kg | Sense of Rotation | Tech. Draw |
|-----------|-------------|-----------|------|----|----|-------|-------|----|-------------------|------------|
| 99.MY.A21 | ER-25 Ø1÷16 | -         | 73.7 | 41 | 20 | 1 : 1 | 6.000 |    |                   | ↓          |
| 99.MY.A22 | ER-25 Ø1÷16 | • 70 bar  | 73.7 | 41 | 20 | 1 : 1 | 6.000 |    |                   | ↓          |
| 99.MY.A41 | ER-20 Ø1÷13 | -         | 71.2 | 41 | 20 | 1 : 1 | 6.000 |    |                   | ↓          |
| 99.MY.A42 | ER-20 Ø1÷13 | • 70 bar  | 71.2 | 41 | 20 | 1 : 1 | 6.000 |    |                   | ↓          |
| 99.MY.A35 | ER-16 Ø1÷10 | -         | 56.3 | 41 | 6  | 1 : 1 | 6.000 |    |                   | ↓          |
| 99.MY.A40 | ER-16 Ø1÷10 | • 10 bar  | 56.3 | 41 | 25 | 1 : 1 | 6.000 | 2  |                   | ↓          |

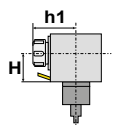

## RADIALE RADIAL

| Code      | Output      | Int Cool. | H  | h1 | Nm | Ratio | Rpm   | Kg | Sense of Rotation | Tech. Draw |
|-----------|-------------|-----------|----|----|----|-------|-------|----|-------------------|------------|
| 99.MY.A33 | ER-20 Ø1÷13 | -         | 59 | 62 | 16 | 1 : 1 | 6.000 |    |                   | ↓          |
| 99.MY.A34 | ER-20 Ø1÷13 | • 70 bar  | 59 | 62 | 16 | 1 : 1 | 6.000 |    |                   | ↓          |

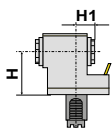

## RADIALE DOPPIO ARRETRATO RADIAL DOUBLE OFFSET

| Code      | Output      | Int Cool. | H  | h1 | Nm | Ratio | Rpm   | Kg | Sense of Rotation | Tech. Draw |
|-----------|-------------|-----------|----|----|----|-------|-------|----|-------------------|------------|
| 99.MY.A38 | ER-16 Ø1÷10 | -         | 59 | 39 | 16 | 1 : 1 | 6.000 | 4  |                   | ↓          |
| 99.MY.A39 | ER-20 Ø1÷13 | -         | 59 | 39 | 16 | 1 : 1 | 6.000 | 2  |                   | ↓          |

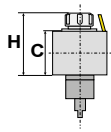

## ASSIALE AXIAL



| Code      | Output      | Int Cool. | H    | C  | Nm | Ratio | Rpm    | Kg | Sense of Rotation | Tech. Draw |
|-----------|-------------|-----------|------|----|----|-------|--------|----|-------------------|------------|
| 99.MY.A02 | ER-25 Ø1+16 | -         | 57.6 | 25 | 35 | 1 : 1 | 6.000  |    |                   | ↓          |
| 99.MY.A03 | ER-25 Ø1+16 | • 80 bar  | 57.6 | 25 | 35 | 1 : 1 | 6.000  |    |                   | ↓          |
| 99.MY.A15 | ER-32 Ø2+20 | -         | 64.3 | 25 | 35 | 1 : 1 | 6.000  | 2  |                   | ↓          |
| 99.MY.A16 | ER-32 Ø2+20 | • 80 bar  | 64.3 | 25 | 35 | 1 : 1 | 6.000  |    |                   | ↓          |
| 99.MY.A01 | ER-16 Ø1+10 | -         | 94.5 | 68 | 6  | 1 : 4 | 24.000 | 5  |                   | ↓          |
| 99.MY.A14 | PF-16 Ø16   | -         | 68.5 | 25 | 35 | 1 : 1 | 6.000  |    |                   | ↓          |

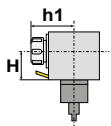

## RADIALE RADIAL

| Code      | Output      | Int Cool. | H  | h1   | Nm | Ratio | Rpm    | Kg | Sense of Rotation | Tech. Draw |
|-----------|-------------|-----------|----|------|----|-------|--------|----|-------------------|------------|
| 99.MY.A05 | ER-25 Ø1+16 | -         | 65 | 84,6 | 35 | 1 : 1 | 6.000  |    |                   | ↓          |
| 99.MY.A06 | ER-25 Ø1+16 | • 80 bar  | 65 | 84,6 | 35 | 1 : 1 | 6.000  |    |                   | ↓          |
| 99.MY.A04 | ER-16 Ø1+10 | -         | 65 | 69,7 | 6  | 1 : 4 | 24.000 | 5  |                   | ↓          |
| 99.MY.A17 | PF-16 Ø16   | -         | 65 | 95,6 | 35 | 1 : 1 | 6.000  |    |                   | ↓          |

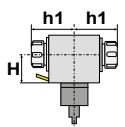

## RADIALE DOPPIO RADIAL DOUBLE

| Code      | Output                         | Int Cool. | H  | h1   | Nm | Ratio | Rpm   | Kg | Sense of Rotation | Tech. Draw |
|-----------|--------------------------------|-----------|----|------|----|-------|-------|----|-------------------|------------|
| 99.MY.A07 | ER-25 / Ø1+16 /<br>ER-25 Ø1+16 | -         | 65 | 84,6 | 35 | 1 : 1 | 6.000 |    |                   | ↓          |

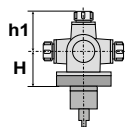

## ORIENTABILE ADJUSTABLE

| Code      | Output      | Int Cool. | H  | h1   | Nm | Ratio | Rpm   | Kg | Sense of Rotation | Tech. Draw |
|-----------|-------------|-----------|----|------|----|-------|-------|----|-------------------|------------|
| 99.MY.A08 | ER-20 Ø1+13 | -         | 65 | 52,5 | 15 | 1 : 1 | 6.000 | 3  |                   | ↓          |
| 99.MY.A13 | ER-20 Ø1+13 | • 80 bar  | 65 | 52,5 | 15 | 1 : 1 | 6.000 | 3  |                   | ↓          |

**ER** Portapinza  
Collet Holder

**PF** Portafresa  
Shell Mill Holder

 Ugualo al Mandrino  
Same as Spindle

 Opposto al Mandrino  
Opposite as Spindle

 Refrigerante Interno  
Internal Coolant

 Scarica il PDF  
PDF Download

MODELLI DI TORNIO COMPATIBILI  
 COMPATIBLE LATHE TYPES

Miyano

Vedi pagine compatibilità 5.14 / 5.20 - See compatibility pages 5.14 / 5.20

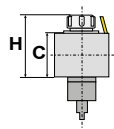

**ASSIALE**  
**AXIAL**

SCAN IT TO SEE

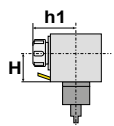

THE TECHNICAL SHEETS

| Code      | Output      | Int Cool. | H    | C  | Nm | Ratio | Rpm    | Kg | Sense of Rotation | Tech. Draw |
|-----------|-------------|-----------|------|----|----|-------|--------|----|-------------------|------------|
| 99.MY.A24 | ER-25 Ø1+16 | -         | 77.2 | 30 | 60 | 1 : 1 | 6.000  | 3  |                   | ↓          |
| 99.MY.A25 | ER-25 Ø1+16 | • 80 bar  | 77.2 | 30 | 60 | 1 : 1 | 6.000  |    |                   | ↓          |
| 99.MY.A09 | ER-32 Ø2+20 | -         | 79.4 | 30 | 60 | 1 : 1 | 6.000  |    |                   | ↓          |
| 99.MY.A10 | ER-32 Ø2+20 | • 80 bar  | 79.4 | 30 | 60 | 1 : 1 | 6.000  |    |                   | ↓          |
| 99.MY.A26 | ER-16 Ø1+10 | -         | 94.5 | 68 | 6  | 1 : 4 | 24.000 | 6  |                   | ↓          |
| 99.MY.A27 | PF-22 Ø22   | -         | 100  | 25 | 60 | 1 : 1 | 6.000  |    |                   | ↓          |

**RADIALE**  
**RADIAL**

| Code      | Output      | Int Cool. | H  | h1 | Nm | Ratio | Rpm   | Kg | Sense of Rotation | Tech. Draw |
|-----------|-------------|-----------|----|----|----|-------|-------|----|-------------------|------------|
| 99.MY.A28 | ER-25 Ø1+16 | -         | 75 | 91 | 60 | 1 : 1 | 6.000 |    |                   | ↓          |
| 99.MY.A29 | ER-25 Ø1+16 | • 80 bar  | 75 | 91 | 60 | 1 : 1 | 6.000 |    |                   | ↓          |
| 99.MY.A11 | ER-32 Ø2+20 | -         | 75 | 94 | 60 | 1 : 1 | 6.000 |    |                   | ↓          |
| 99.MY.A12 | ER-32 Ø2+20 | • 80 bar  | 75 | 94 | 50 | 1 : 1 | 6.000 | 8  |                   | ↓          |

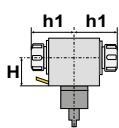
**RADIALE DOPPIO**  
**RADIAL DOUBLE**

| Code      | Output                         | Int Cool. | H  | h1   | Nm | Ratio | Rpm   | Kg | Sense of Rotation | Tech. Draw |
|-----------|--------------------------------|-----------|----|------|----|-------|-------|----|-------------------|------------|
| 99.MY.A18 | ER-32 / Ø2+20 /<br>ER-32 Ø2+20 | -         | 75 | 93,9 | 60 | 1 : 1 | 6.000 |    |                   | ↓          |

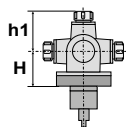
**ORIENTABILE**  
**ADJUSTABLE**

| Code      | Output      | Int Cool. | H  | h1   | Nm | Ratio | Rpm   | Kg | Sense of Rotation | Tech. Draw |
|-----------|-------------|-----------|----|------|----|-------|-------|----|-------------------|------------|
| 99.MY.A19 | ER-20 Ø1+13 | -         | 75 | 52,2 | 15 | 1 : 1 | 6.000 | 3  |                   | ↓          |
| 99.MY.A20 | ER-20 Ø1+13 | • 80 bar  | 75 | 52,2 | 15 | 1 : 1 | 6.000 | 3  |                   | ↓          |

**ER** Portapinza  
Collet Holder

**PF** Portafresa  
Shell Mill Holder

 Uguale al Mandrino  
Same as Spindle

 Opposto al Mandrino  
Opposite as Spindle

 Refrigerante Interno  
Internal Coolant

 Scarica il PDF  
PDF Download



Nakamura-Tome



BMT 44 - BMT 55 - BMT 65

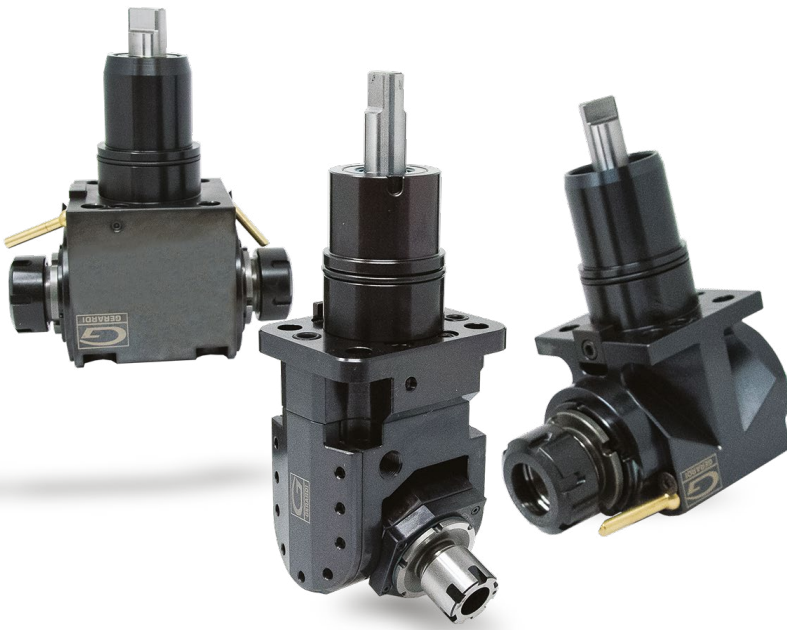

**DOTAZIONE STANDARD**  
STANDARD EQUIPMENT



Chiave bloccaggio albero / ugello refrigerazione / vite bloccaggio ugello / viti bloccaggio motorizzato O-ring

Tool shaft lock wrench / cooling nozzle / nozzle lock screws / Driven tool locking screws / O-ring

---

**CAMBI RAPIDI MODULARI**  
MODULAR QUICK CHANGE



Facile e veloce sistema modulare per il cambio rapido delle diverse tipologie di portautensili con la sede per pinza ER (DIN6499).

Modular toolholder system for the fitting of toolholders in a spindle unit with ER collets (DIN6499) outputs.

Il valore della coppia, espresso in Nm, è il massimo consentito. Per una maggiore durata, si consiglia di mantenerlo sotto tale soglia  
The torque value, expressed in Nm, is the maximum allowed. For longer life, it is recommended to keep it below this limit

| Type  | c1 | c2  | d  | d1 | d2 | f   | f1 | f2 | f3    | h1    | h2 | h3   | i1 | i2   | t  | t1 |
|-------|----|-----|----|----|----|-----|----|----|-------|-------|----|------|----|------|----|----|
| BMT44 | 20 | 5,5 | 44 | 40 | 15 | M8  | 40 | 55 | 12-15 | 91    | 63 | 28   | 62 | 79,5 | 8  | 12 |
| BMT55 | 20 | 5,5 | 55 | 50 | 17 | M10 | 50 | 60 | 12-15 | 108   | 70 | 29,5 | 79 | 84   | 8  | 10 |
| BMT65 | 20 | 5,5 | 65 | -  | -  | -   | 69 | 71 | 12-15 | 115,5 | -  | 31   | 92 | 100  | 10 | -  |

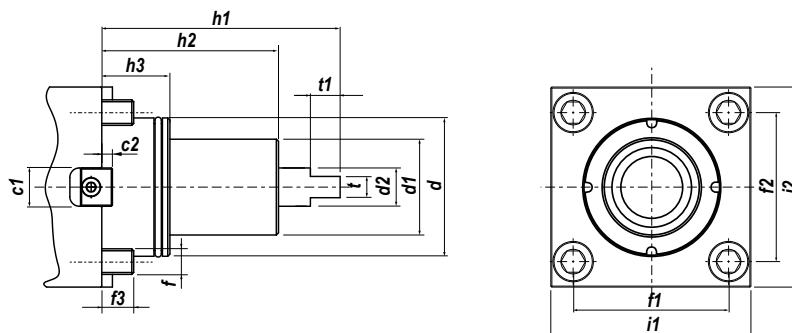

IN FASE D'ORDINE SPECIFICARE - IN CASE OF ORDER PLEASE SPECIFY:  
costruttore, modello e numero posizioni in torretta - machine builder, model and turret position numbers

## ASSIALE - AXIAL

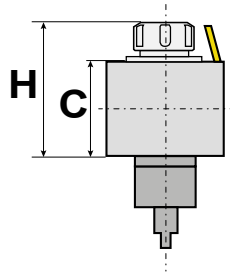
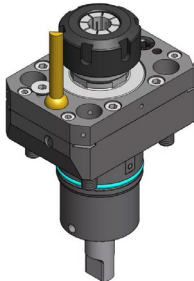

L'asse dell'utensile è in linea all'asse della torretta o del mandrino

The tool axis is aligned to the turret or spindle axis

## RADIALE - RADIAL

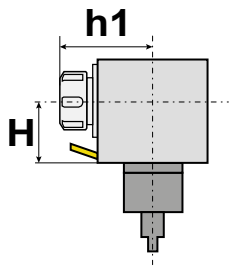
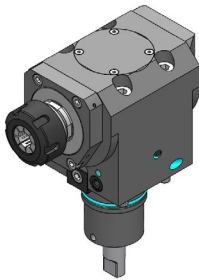

L'asse dell'utensile è perpendicolare all'asse della torretta o del mandrino

The tool axis is perpendicular to the turret or spindle axis

## RADIALE DOPPIO - DOUBLE RADIAL

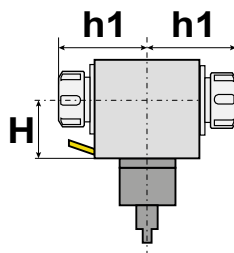
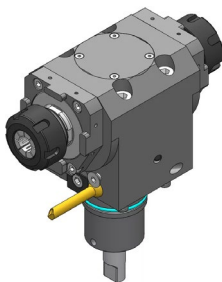

Il motorizzato ha due uscite situate sullo stesso asse radiale, ma rivolte in direzioni opposte

The driven tool has two outputs situated on the same radial axis, but facing in opposite directions

## ORIENTABILE - ADJUSTABLE

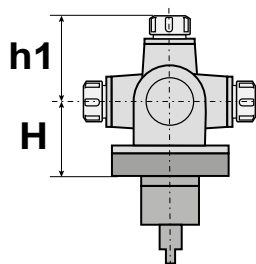

Permettono di inclinare l'asse dell'utensile secondo un angolo specifico richiesto dalla lavorazione

They allow the tool axis to be tilted to a specific angle required for the machining operation

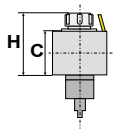

## ASSIALE AXIAL



| Code      | Output      | Int Cool. | H    | C  | Nm | Ratio | Rpm   | Kg | Sense of Rotation | Tech. Draw |
|-----------|-------------|-----------|------|----|----|-------|-------|----|-------------------|------------|
| 99.NK.A40 | ER-25 Ø1÷16 | -         | 57.2 | 25 | 40 | 1 : 1 | 6.000 | 2  |                   | ↓          |
| 99.NK.A43 | ER-25 Ø1÷16 | • 70 bar  | 57.2 | 25 | 40 | 1 : 1 | 6.000 |    |                   | ↓          |

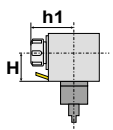

## RADIALE RADIAL

| Code      | Output      | Int Cool. | H  | h1   | Nm | Ratio | Rpm   | Kg | Sense of Rotation | Tech. Draw |
|-----------|-------------|-----------|----|------|----|-------|-------|----|-------------------|------------|
| 99.NK.A50 | ER-25 Ø1÷16 | -         | 60 | 84,9 | 40 | 1 : 1 | 6.000 | 4  |                   | ↓          |
| 99.NK.A53 | ER-25 Ø1÷16 | • 70 bar  | 60 | 84,9 | 40 | 1 : 1 | 6.000 |    |                   | ↓          |
| 99.NK.A30 | ER-25 Ø1÷16 | -         | 75 | 84,9 | 40 | 1 : 1 | 6.000 | 5  |                   | ↓          |
| 99.NK.A33 | ER-25 Ø1÷16 | • 70 bar  | 75 | 84,9 | 40 | 1 : 1 | 6.000 |    |                   | ↓          |
| 99.NK.A36 | ER-16 Ø1÷10 | -         | 60 | 69,7 | 6  | 1 : 4 | 6.000 |    |                   | ↓          |

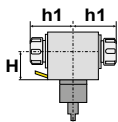

## RADIALE DOPPIO RADIAL DOUBLE

| Code      | Output                         | Int Cool. | H  | h1   | Nm | Ratio | Rpm   | Kg | Sense of Rotation | Tech. Draw |
|-----------|--------------------------------|-----------|----|------|----|-------|-------|----|-------------------|------------|
| 99.NK.A70 | ER-25 / Ø1÷16 /<br>ER-25 Ø1÷16 | -         | 60 | 84,9 | 40 | 1 : 1 | 6.000 |    |                   | ↓          |
| 99.NK.A80 | ER-25 / Ø1÷16 /<br>ER-25 Ø1÷16 | -         | 75 | 84,9 | 40 | 1 : 1 | 6.000 |    |                   | ↓          |

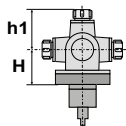

## ORIENTABILE ADJUSTABLE

| Code      | Output      | Int Cool. | H    | h1   | Nm | Ratio | Rpm   | Kg | Sense of Rotation | Tech. Draw |
|-----------|-------------|-----------|------|------|----|-------|-------|----|-------------------|------------|
| 99.NK.A59 | ER-16 Ø1÷10 | -         | 68.5 | 56,5 | 10 | 1 : 1 | 6.000 | 3  |                   | ↓          |
| 99.NK.A69 | ER-16 Ø1÷10 | • 70 bar  | 68.5 | 56,5 | 10 | 1 : 1 | 6.000 | 3  |                   | ↓          |

Vedi pagine compatibilità 5.14 / 5.20 - See compatibility pages 5.14 / 5.20

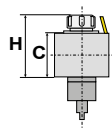

## ASSIALE AXIAL

SCAN IT TO SEE



THE TECHNICAL SHEETS

| Code      | Output      | Int Cool. | H    | C  | Nm | Ratio | Rpm   | Kg | Sense of Rotation | Tech. Draw |
|-----------|-------------|-----------|------|----|----|-------|-------|----|-------------------|------------|
| 99.NK.A01 | ER-25 Ø1+16 | -         | 57.2 | 25 | 63 | 1 : 1 | 6.000 |    |                   |            |
| 99.NK.A02 | ER-25 Ø1+16 | • 70 bar  | 57.2 | 25 | 63 | 1 : 1 | 6.000 |    |                   |            |
| 99.NK.A03 | ER-32 Ø2+20 | -         | 72.2 | 25 | 63 | 1 : 1 | 6.000 |    |                   |            |
| 99.NK.A04 | ER-32 Ø2+20 | • 70 bar  | 72.2 | 25 | 63 | 1 : 1 | 6.000 |    |                   |            |

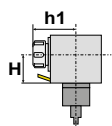

## RADIALE RADIAL

| Code      | Output      | Int Cool. | H  | h1   | Nm | Ratio | Rpm   | Kg | Sense of Rotation | Tech. Draw |
|-----------|-------------|-----------|----|------|----|-------|-------|----|-------------------|------------|
| 99.NK.A20 | ER-25 Ø1+16 | -         | 55 | 86,2 | 63 | 1 : 1 | 6.000 |    |                   |            |
| 99.NK.A13 | ER-32 Ø2+20 | -         | 55 | 93,7 | 63 | 1 : 1 | 6.000 |    |                   |            |
| 99.NK.A05 | ER-25 Ø1+16 | -         | 65 | 86,2 | 63 | 1 : 1 | 6.000 |    |                   |            |
| 99.NK.A23 | ER-32 Ø2+20 | -         | 65 | 93,7 | 63 | 1 : 1 | 6.000 |    |                   |            |
| 99.NK.A07 | ER-25 Ø1+16 | -         | 75 | 86,2 | 63 | 1 : 1 | 6.000 |    |                   |            |
| 99.NK.A15 | ER-32 Ø2+20 | -         | 75 | 93,7 | 63 | 1 : 1 | 6.000 |    |                   |            |
| 99.NK.A25 | ER-25 Ø1+16 | • 70 bar  | 55 | 86,2 | 63 | 1 : 1 | 6.000 |    |                   |            |
| 99.NK.A14 | ER-32 Ø2+20 | • 70 bar  | 55 | 93,7 | 63 | 1 : 1 | 6.000 |    |                   |            |
| 99.NK.A06 | ER-25 Ø1+16 | • 70 bar  | 65 | 86,2 | 63 | 1 : 1 | 6.000 |    |                   |            |
| 99.NK.A24 | ER-32 Ø2+20 | • 70 bar  | 65 | 93,7 | 63 | 1 : 1 | 6.000 |    |                   |            |
| 99.NK.A08 | ER-25 Ø1+16 | • 70 bar  | 75 | 86,2 | 63 | 1 : 1 | 6.000 |    |                   |            |
| 99.NK.A16 | ER-32 Ø2+20 | • 70 bar  | 75 | 93,7 | 63 | 1 : 1 | 6.000 |    |                   |            |

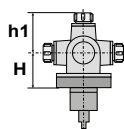

## ORIENTABILE ADJUSTABLE

| Code      | Output      | Int Cool. | H  | h1   | Nm | Ratio | Rpm   | Kg | Sense of Rotation | Tech. Draw |
|-----------|-------------|-----------|----|------|----|-------|-------|----|-------------------|------------|
| 99.NK.A22 | ER-20 Ø1+13 | -         | 71 | 52,5 | 15 | 1 : 1 | 6.000 | 4  |                   |            |
| 99.NK.A32 | ER-20 Ø1+13 | • 70 bar  | 71 | 52,5 | 15 | 1 : 1 | 6.000 | 3  |                   |            |

**ER** Portapinza  
Collet Holder

**PF** Portafresa  
Shell Mill Holder

 Ugualmente al Mandrino  
Same as Spindle

 Opposto al Mandrino  
Opposite as Spindle

 Refrigerante Interno  
Internal Coolant

 Scarica il PDF  
PDF Download

Vedi pagine compatibilità 5.14 / 5.20 - See compatibility pages 5.14 / 5.20

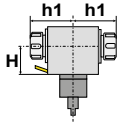

## RADIALE DOPPIO

### RADIAL DOUBLE

SCAN IT TO SEE



THE TECHNICAL SHEETS

| Code      | Output                      | Int Cool. | H  | h1   | Nm | Ratio | Rpm   | Kg | Sense of Rotation | Tech. Draw |
|-----------|-----------------------------|-----------|----|------|----|-------|-------|----|-------------------|------------|
| 99.NK.A09 | ER-25 Ø1+16                 | -         | 55 | 86,2 | 63 | 1 : 1 | 6.000 |    |                   |            |
| 99.NK.A71 | ER-32 / Ø2+20 / ER-32 Ø2+20 | -         | 55 | 93,7 | 63 | 1 : 1 | 6.000 |    |                   |            |
| 99.NK.A10 | ER-25 Ø1+16                 | -         | 65 | 86,2 | 63 | 1 : 1 | 6.000 |    |                   |            |
| 99.NK.A81 | ER-32 / Ø2+20 / ER-32 Ø2+20 | -         | 65 | 93,7 | 63 | 1 : 1 | 6.000 | 6  |                   |            |
| 99.NK.A11 | ER-25 Ø1+16                 | -         | 75 | 86,2 | 63 | 1 : 1 | 6.000 |    |                   |            |
| 99.NK.A91 | ER-32 / Ø2+20 / ER-32 Ø2+20 | -         | 75 | 93,7 | 63 | 1 : 1 | 6.000 | 6  |                   |            |

Vedi pagine compatibilità 5.14 / 5.20 - See compatibility pages 5.14 / 5.20

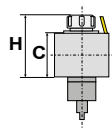

## ASSIALE AXIAL

SCAN IT TO SEE



THE TECHNICAL SHEETS

| Code      | Output      | Int Cool. | H    | C    | Nm | Ratio | Rpm   | Kg | Sense of Rotation | Tech. Draw |
|-----------|-------------|-----------|------|------|----|-------|-------|----|-------------------|------------|
| 99.NK.A51 | ER-32 Ø2+20 | -         | 77.9 | 38,5 | 63 | 1 : 1 | 6.000 | 4  |                   |            |
| 99.NK.A52 | ER-32 Ø2+20 | • 70 bar  | 77.9 | 38,5 | 63 | 1 : 1 | 6.000 |    |                   |            |

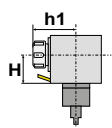

## RADIALE RADIAL

| Code      | Output      | Int Cool. | H  | h1   | Nm | Ratio | Rpm   | Kg | Sense of Rotation | Tech. Draw |
|-----------|-------------|-----------|----|------|----|-------|-------|----|-------------------|------------|
| 99.NK.A58 | ER-32 Ø2+20 | -         | 65 | 93,9 | 63 | 1 : 1 | 6.000 | 7  |                   |            |
| 99.NK.A62 | ER-32 Ø2+20 | • 70 bar  | 65 | 93,9 | 63 | 1 : 1 | 6.000 |    |                   |            |
| 99.NK.A12 | ER-32 Ø2+20 | -         | 80 | 93,9 | 63 | 1 : 1 | 6.000 | 9  |                   |            |
| 99.NK.A17 | ER-32 Ø2+20 | • 70 bar  | 80 | 93,9 | 63 | 1 : 1 | 6.000 | 10 |                   |            |

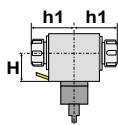

## RADIALE DOPPIO RADIAL DOUBLE

| Code      | Output                         | Int Cool. | H  | h1   | Nm | Ratio | Rpm   | Kg | Sense of Rotation | Tech. Draw |
|-----------|--------------------------------|-----------|----|------|----|-------|-------|----|-------------------|------------|
| 99.NK.A78 | ER-32 / Ø2+20 /<br>ER-32 Ø2+20 | -         | 65 | 93,9 | 63 | 1 : 1 | 6.000 | 9  |                   |            |

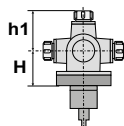

## ORIENTABILE ADJUSTABLE

| Code      | Output      | Int Cool. | H  | h1   | Nm | Ratio | Rpm   | Kg | Sense of Rotation | Tech. Draw |
|-----------|-------------|-----------|----|------|----|-------|-------|----|-------------------|------------|
| 99.NK.A82 | ER-25 Ø1+16 | -         | 75 | 67,2 | 15 | 1 : 1 | 6.000 | 5  |                   |            |
| 99.NK.A19 | ER-25 Ø1+16 | • 70 bar  | 80 | 67,2 | 15 | 1 : 1 | 6.000 | 5  |                   |            |

VDI 30 - VDI 40 - BMT 55 / 60

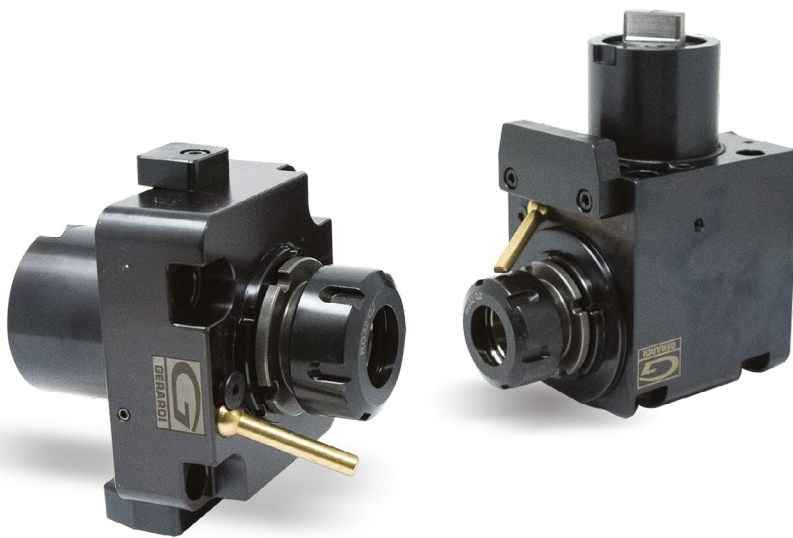

**USCITA C. ISO26623**  
C. ISO26623 OUTPUT

Disponibile su richiesta  
Available on request



**DOTAZIONE STANDARD**  
STANDARD EQUIPMENT

Chiave bloccaggio albero / ugello refrigerazione / vite bloccaggio ugello / viti bloccaggio motorizzato O-ring

Tool shaft lock wrench / cooling nozzle / nozzle lock screws / Driven tool locking screws / O-ring



**CAMBI RAPIDI MODULARI**  
MODULAR QUICK CHANGE

Facile e veloce sistema modulare per il cambio rapido delle diverse tipologie di portautensili con la sede per pinza ER (DIN6499).

Modular toolholder system for the fitting of toolholders in a spindle unit with ER collets (DIN6499) outputs.

**Il valore della coppia, espresso in Nm, è il massimo consentito. Per una maggiore durata, si consiglia di mantenerlo sotto tale soglia**  
The torque value, expressed in Nm, is the maximum allowed. For longer life, it is recommended to keep it below this limit

| Type  | c1 | c2 | d   | d1 | f1 | f2 | f3 | f4 | f5 | h1  | h2 | h3 | t  |
|-------|----|----|-----|----|----|----|----|----|----|-----|----|----|----|
| BMT55 | -  | -  | Ø55 | -  | 65 | 40 | 40 | 40 | 40 | 102 | 64 | -  | 10 |
| BMT60 | 62 | 60 | Ø60 | 50 | 73 | 26 | 39 | 39 | 26 | 62  | 49 | 8  | 10 |

| Type   | A  | B  | C   |
|--------|----|----|-----|
| VDI 30 | 55 | 69 | Ø29 |
| VDI 40 | 63 | 93 | Ø29 |

**BMT**

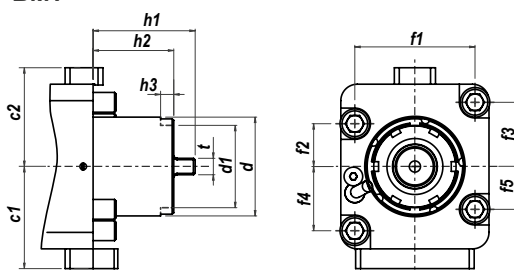

**VDI**

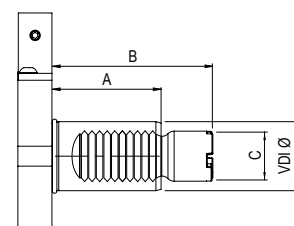

IN FASE D'ORDINE SPECIFICARE - IN CASE OF ORDER PLEASE SPECIFY:  
costruttore, modello e numero posizioni in torretta - machine builder, model and turret position numbers

## ASSIALE - AXIAL

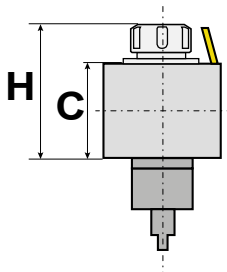
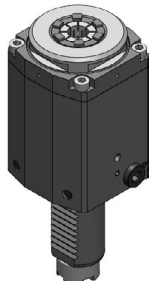

L'asse dell'utensile è in linea all'asse della torretta o del mandrino

The tool axis is aligned to the turret or spindle axis

## RADIALE - RADIAL

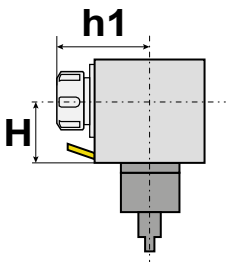
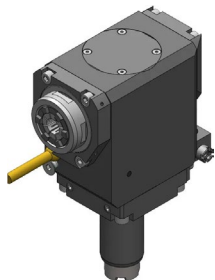

L'asse dell'utensile è perpendicolare all'asse della torretta o del mandrino

The tool axis is perpendicular to the turret or spindle axis

## RADIALE DOPPIO - DOUBLE RADIAL

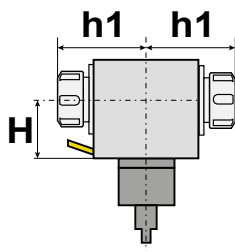
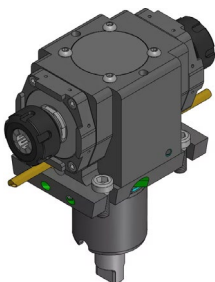

Il motorizzato ha due uscite situate sullo stesso asse radiale, ma rivolte in direzioni opposte

The driven tool has two outputs situated on the same radial axis, but facing in opposite directions

## RADIALE ARRETRATO - RADIAL REAR OFFSET

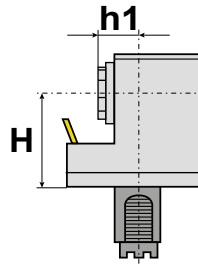
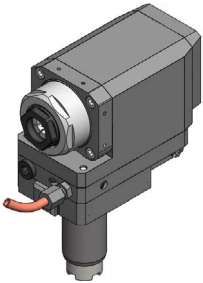

L'asse dell'utensile è perpendicolare all'asse della torretta o del mandrino ma traslato verso il corpo del motorizzato

The tool axis is perpendicular to the axis of the turret or spindle but offset towards the motorised unit

## ORIENTABILE - ADJUSTABLE

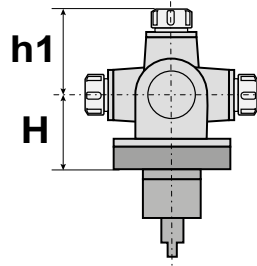
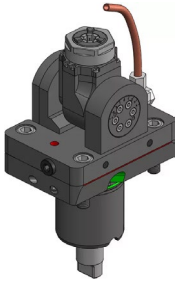

Permettono di inclinare l'asse dell'utensile secondo un angolo specifico richiesto dalla lavorazione

They allow the tool axis to be tilted to a specific angle required for the machining operation

MODELLI DI TORNIO COMPATIBILI  
 COMPATIBLE LATHE TYPES

Okuma

Vedi pagine compatibilità 5.14 / 5.20 - See compatibility pages 5.14 / 5.20

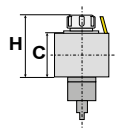

## ASSIALE AXIAL

SCAN IT TO SEE



THE TECHNICAL SHEETS

| Code      | Output      | Int Cool. | H    | C    | Nm | Ratio | Rpm   | Kg | Sense of Rotation | Tech. Draw |
|-----------|-------------|-----------|------|------|----|-------|-------|----|-------------------|------------|
| 99.OK.A33 | ER-25 Ø1+16 | -         | 86.1 | 75,5 | 32 | 1 : 1 | 6.000 |    |                   |            |
| 99.OK.A34 | ER-25 Ø1+16 | • 80 bar  | 86.1 | 75,5 | 32 | 1 : 1 | 6.000 |    |                   |            |

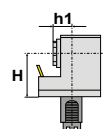

## RADIALE ARRETRATO RADIAL OFFSET

| Code      | Output      | Int Cool. | H  | h1 | Nm | Ratio | Rpm   | Kg | Sense of Rotation | Tech. Draw |
|-----------|-------------|-----------|----|----|----|-------|-------|----|-------------------|------------|
| 99.OK.A36 | ER-25 Ø1+16 | -         | 70 | 41 | 16 | 1 : 1 | 8.000 | 4  |                   |            |
| 99.OK.A42 | ER-25 Ø1+16 | • 80 bar  | 70 | 41 | 16 | 1 : 1 | 8.000 |    |                   |            |

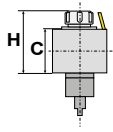

## ASSIALE AXIAL



| Code      | Output      | Int Cool. | H    | C    | Nm | Ratio | Rpm   | Kg | Sense of Rotation | Tech. Draw |
|-----------|-------------|-----------|------|------|----|-------|-------|----|-------------------|------------|
| 99.OK.A23 | ER-32 Ø2+20 | • 70 bar  | 98.6 | 80,5 | 70 | 1 : 1 | 6.000 |    |                   | ↓          |
| 99.OK.A18 | ER-32 Ø2+20 | -         | 98.6 | 80,5 | 70 | 1 : 1 | 6.000 |    |                   | ↓          |

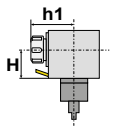

## RADIALE RADIAL

| Code      | Output      | Int Cool. | H  | h1 | Nm | Ratio | Rpm   | Kg | Sense of Rotation | Tech. Draw |
|-----------|-------------|-----------|----|----|----|-------|-------|----|-------------------|------------|
| 99.OK.A19 | ER-32 Ø2+20 | -         | 70 | 84 | 60 | 1 : 1 | 6.000 |    |                   | ↓          |
| 99.OK.A39 | ER-40 Ø3+30 | • 80 bar  | 85 | 35 | 40 | 1 : 1 | 8.000 |    |                   | ↓          |

MODELLI DI TORNIO COMPATIBILI  
 COMPATIBLE LATHE TYPES

Okuma

Vedi pagine compatibilità 5.14 / 5.20 - See compatibility pages 5.14 / 5.20

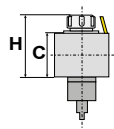

## ASSIALE AXIAL

SCAN IT TO SEE



THE TECHNICAL SHEETS

| Code      | Output      | Int Cool. | H    | C  | Nm | Ratio | Rpm   | Kg | Sense of Rotation | Tech. Draw |
|-----------|-------------|-----------|------|----|----|-------|-------|----|-------------------|------------|
| 99.OK.A01 | ER-25 Ø1+16 | -         | 71.7 | 38 | 40 | 1 : 1 | 6.000 | 4  |                   |            |
| 99.OK.A02 | ER-25 Ø1+16 | • 70 bar  | 71.7 | 38 | 40 | 1 : 1 | 8.000 |    |                   |            |
| 99.OK.A14 | ER-32 Ø2+20 | -         | 78   | 38 | 70 | 1 : 1 | 6.000 |    |                   |            |
| 99.OK.A15 | ER-32 Ø2+20 | • 70 bar  | 78   | 38 | 40 | 1 : 1 | 6.000 | 4  |                   |            |
| 99.OK.A16 | PF-22 Ø22   | -         | 96   | 38 | 40 | 1 : 1 | 6.000 | 4  |                   |            |
| 99.OK.A17 | PF-27 Ø27   | • 70 bar  | 97   | 38 | 40 | 1 : 1 | 6.000 | 4  |                   |            |

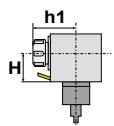

## RADIALE RADIAL

| Code      | Output      | Int Cool. | H  | h1 | Nm | Ratio | Rpm   | Kg | Sense of Rotation | Tech. Draw |
|-----------|-------------|-----------|----|----|----|-------|-------|----|-------------------|------------|
| 99.OK.A03 | ER-25 Ø1+16 | -         | 65 | 94 | 60 | 1 : 1 | 6.000 |    |                   |            |
| 99.OK.A04 | ER-25 Ø1+16 | • 70 bar  | 65 | 94 | 60 | 1 : 1 | 6.000 |    |                   |            |

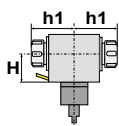

## RADIALE DOPPIO RADIAL DOUBLE

| Code      | Output      | Int Cool. | H  | h1   | Nm | Ratio | Rpm   | Kg | Sense of Rotation | Tech. Draw |
|-----------|-------------|-----------|----|------|----|-------|-------|----|-------------------|------------|
| 99.OK.A05 | ER-25 Ø1+16 | -         | 65 | 95,5 | 40 | 1 : 1 | 6.000 |    |                   |            |

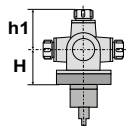

## ORIENTABILE ADJUSTABLE

| Code      | Output      | Int Cool. | H  | h1 | Nm | Ratio | Rpm   | Kg | Sense of Rotation | Tech. Draw |
|-----------|-------------|-----------|----|----|----|-------|-------|----|-------------------|------------|
| 99.OK.A06 | ER-20 Ø1+13 | -         | 60 | 35 | 40 | 1 : 1 | 6.000 | 5  |                   |            |
| 99.OK.A07 | ER-20 Ø1+13 | • 70 bar  | 60 | 35 | 40 | 1 : 1 | 6.000 | 5  |                   |            |

**ER** Portapinza  
Collet Holder

**PF** Portafresa  
Shell Mill Holder

 Ugualo al Mandrino  
Same as Spindle

 Opposto al Mandrino  
Opposite as Spindle

 Refrigerante Interno  
Internal Coolant

 Scarica il PDF  
PDF Download

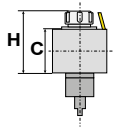

## ASSIALE AXIAL



| Code      | Output      | Int Cool. | H  | C    | Nm | Ratio | Rpm   | Kg | Sense of Rotation | Tech. Draw |
|-----------|-------------|-----------|----|------|----|-------|-------|----|-------------------|------------|
| 99.OK.A80 | ER-32 Ø2+20 | -         | 79 | 38,5 | 60 | 1 : 1 | 6.000 | 4  |                   | ↓          |
| 99.OK.A81 | ER-32 Ø2+20 | • 70 bar  | 79 | 38,5 | 60 | 1 : 1 | 6.000 |    |                   | ↓          |

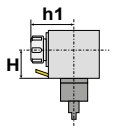

## RADIALE RADIAL

| Code      | Output      | Int Cool. | H  | h1 | Nm | Ratio | Rpm   | Kg | Sense of Rotation | Tech. Draw |
|-----------|-------------|-----------|----|----|----|-------|-------|----|-------------------|------------|
| 99.OK.A82 | ER-32 Ø2+20 | -         | 70 | 94 | 60 | 1 : 1 | 6.000 | 8  |                   | ↓          |
| 99.OK.A83 | ER-32 Ø2+20 | • 70 bar  | 70 | 94 | 60 | 1 : 1 | 6.000 | 8  |                   | ↓          |



# MODULAR QUICK CHANGE ADAPTORS



COMPATIBILI CON TUTTE LE USCITE ER - COMPATIBLE WITH ALL ER OUTPUTS

## SISTEMA MODULARE MODULAR SYSTEM

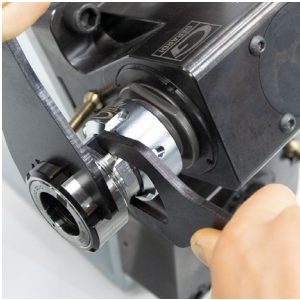

Facile e veloce sistema modulare universale per cambiare rapidamente diverse tipologie di utensili.

An easy modular system to replace quickly any tool you need.

## VANTAGGI ADVANTAGES



Aiutano a ridurre i costi-extra per l'acquisto di nuovi motorizzati o teste angolari.

The costs for further requirements of spindle units can be reduced by using the universal quick change adaptors

## ALTE PRESTAZIONI HIGH PERFORMANCE



Ghiera con cuscinetto a sfera e losanga di trascinamento removibile per una maggiore rigidità.

High rigidity thanks to the ball bearing nut and the removable diamond plate

## COMPATIBILITÀ COMPATIBILITY



Ampia gamma di uscite disponibili adatte al montaggio su qualsiasi tipologia di motorizzato o testa angolare con uscita ER

Wide range of outputs available. Ball bearing nut and removable diamond plate for highest rigidity.

I cambi rapidi modulari Gerardi mantenendo il presetting precedentemente realizzato consentono un notevole risparmio dei costi ed un ottimizzazione dei tempi ciclo. Sono perfettamente compatibili con tutti i motorizzati e le teste angolari aventi uscita ER DIN6499 e possono essere utilizzati sia con refrigerante interno che esterno.

The Gerardi modular quick change adaptors keep the tool presetting previously made and allow great costs and machining times saving. They are perfectly compatible with all driven tools and angle head with ER DIN6499 output and they can be used with internal or external coolant.

- Nuovi cambi rapidi modulari 2.0 a FORTE SERRAGGIO, 100% Made in Italy.
- Prestazioni garantite e maggior rigidità sui motorizzati Gerardi grazie alla losanga di trascinamento (rimovibile) e alla ghiera con cuscinetto a sfera.
- Adattabili a motorizzati con uscita refrigerante sia interna che esterna.
- Si consiglia di non superare i 10.000 Rpm utilizzando i cambi rapidi

- Universal HIGH TORQUE modular quick change adaptor 100% Made in Italy.
- Guaranteed higher rigidity and performances on Gerardi driven tools thanks to the removable diamond plate and the ball bearing nut
- Suitable for ER toolholder with external and internal coolant supply
- Using the quick change adaptors, we suggest not to exceed 10.000 Rpm

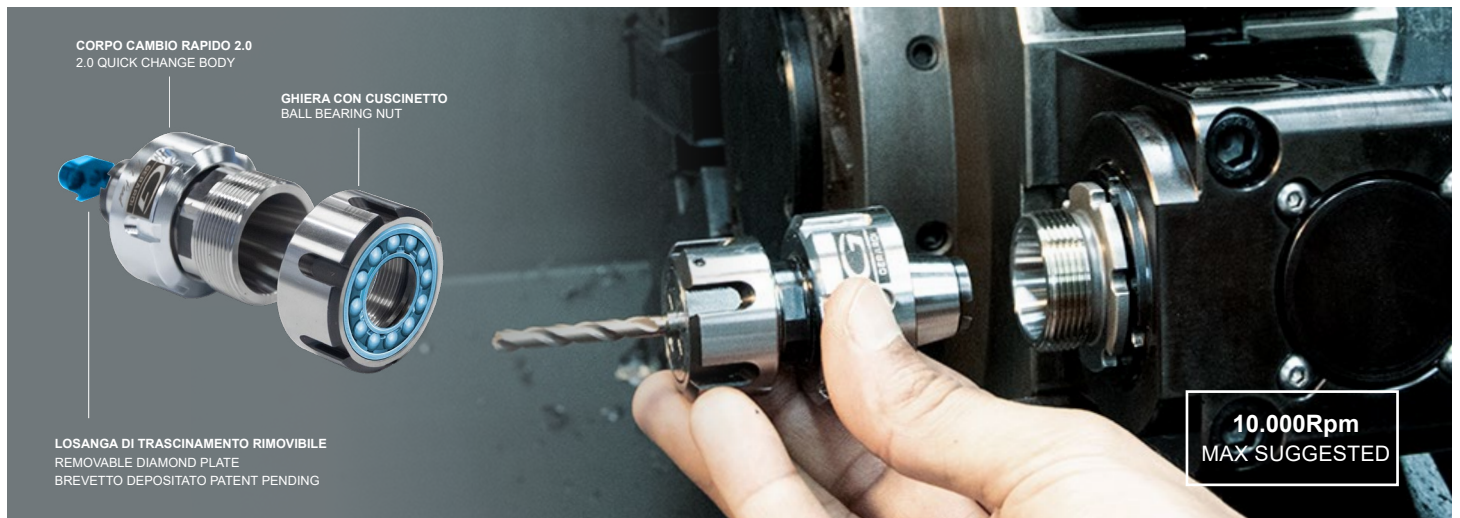

Vedi Pagine 7.14 - 7.15 - See pages 7.14 - 7.15



ER OUTPUTS COMPATIBLE



2 YEARS GUARANTEED



100% MADE IN ITALY

# SPINNER



VDI 30 / BMT 45

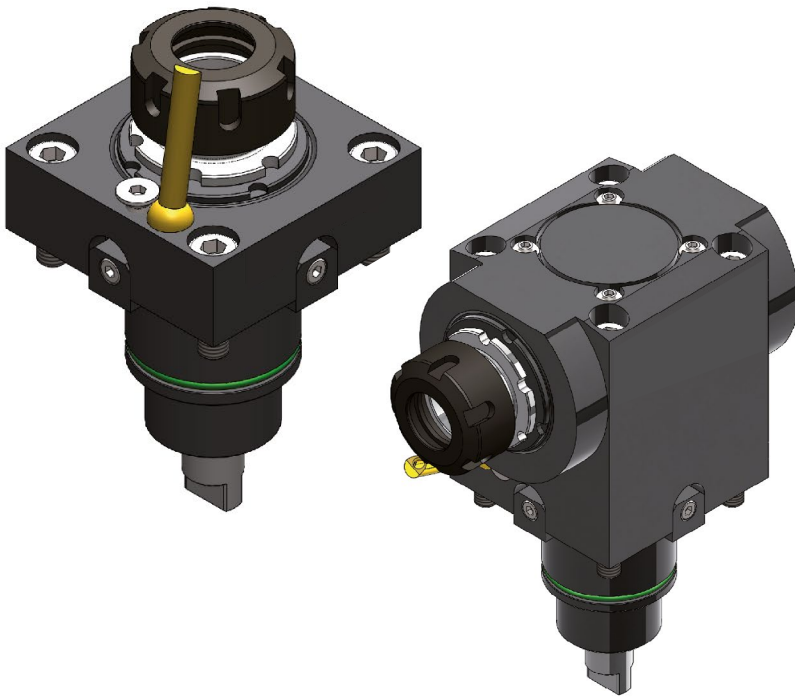

### DOTAZIONE STANDARD STANDARD EQUIPMENT



Chiave bloccaggio albero / ugello refrigerazione / vite bloccaggio ugello / viti bloccaggio motorizzato O-ring

Tool shaft lock wrench / cooling nozzle / nozzle lock screws / Driven tool locking screws / O-ring

### CAMBI RAPIDI MODULARI MODULAR QUICK CHANGE



Facile e veloce sistema modulare per il cambio rapido delle diverse tipologie di portautensili con la sede per pinza ER (DIN6499).

Modular toolholder system for the fitting of toolholders in a spindle unit with ER collets (DIN6499) outputs.

Il valore della coppia, espresso in Nm, è il massimo consentito. Per una maggiore durata, si consiglia di mantenerlo sotto tale soglia  
The torque value, expressed in Nm, is the maximum allowed. For longer life, it is recommended to keep it below this limit

| Type  | d  | d1 | d2 | f | f1 | f2 | f3 | h1 | h2 | h3 | i1 | i2 | t | t1 |
|-------|----|----|----|---|----|----|----|----|----|----|----|----|---|----|
| BMT45 | 45 | 35 | 24 | - | 58 | 58 | -  | 72 | 49 | 35 | 75 | 75 | 8 | 7  |

| Type   | A  | B  | ØD | E |
|--------|----|----|----|---|
| VDI 25 | 45 | 73 | 23 | 8 |

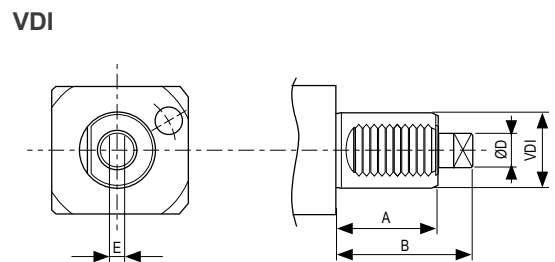
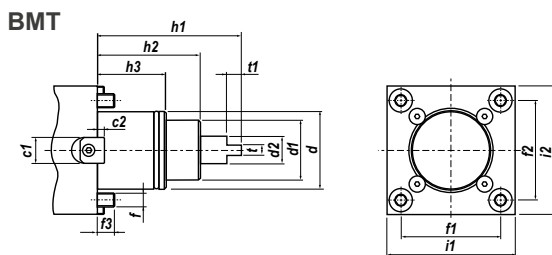

IN FASE D'ORDINE SPECIFICARE - IN CASE OF ORDER PLEASE SPECIFY:  
costruttore, modello e numero posizioni in torretta - machine builder, model and turret position numbers

## ASSIALE - AXIAL

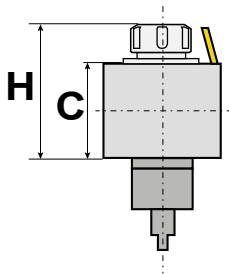
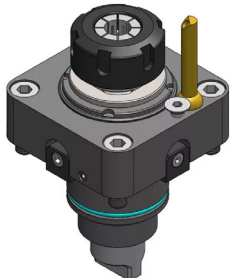

L'asse dell'utensile è in linea all'asse della torretta o del mandrino

The tool axis is aligned to the turret or spindle axis

## RADIALE - RADIAL

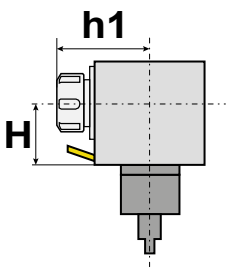

L'asse dell'utensile è perpendicolare all'asse della torretta o del mandrino

The tool axis is perpendicular to the turret or spindle axis

## ORIENTABILE - ADJUSTABLE

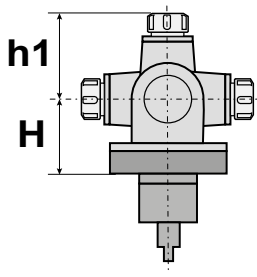

Permettono di inclinare l'asse dell'utensile secondo un angolo specifico richiesto dalla lavorazione

They allow the tool axis to be tilted to a specific angle required for the machining operation

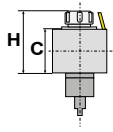

## ASSIALE AXIAL



| Code      | Output      | Int Cool. | H    | C  | Nm | Ratio | Rpm   | Kg | Sense of Rotation | Tech. Draw |
|-----------|-------------|-----------|------|----|----|-------|-------|----|-------------------|------------|
| 99.SP.A01 | ER-25 Ø1÷16 | -         | 58.7 | 25 | 35 | 1 : 1 | 8.000 | 2  |                   | ↓          |
| 99.SP.A02 | ER-25 Ø1÷16 | • 80 bar  | 58.7 | 25 | 35 | 1 : 1 | 8.000 | 2  |                   | ↓          |

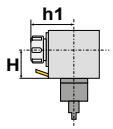

## RADIALE RADIAL

| Code      | Output      | Int Cool. | H  | h1   | Nm | Ratio | Rpm   | Kg | Sense of Rotation | Tech. Draw |
|-----------|-------------|-----------|----|------|----|-------|-------|----|-------------------|------------|
| 99.SP.A05 | ER-25 Ø1÷16 | -         | 85 | 84,9 | 35 | 1 : 1 | 8.000 | 6  |                   | ↓          |
| 99.SP.A06 | ER-25 Ø1÷16 | • 80 bar  | 85 | 84,9 | 35 | 1 : 1 | 8.000 | 5  |                   | ↓          |

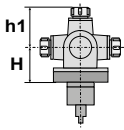

## ORIENTABILE ADJUSTABLE

| Code      | Output      | Int Cool. | H  | h1 | Nm | Ratio | Rpm   | Kg   | Sense of Rotation | Tech. Draw |
|-----------|-------------|-----------|----|----|----|-------|-------|------|-------------------|------------|
| 99.SP.A13 | ER-20 Ø1÷13 | -         | 65 | 55 | 17 | 1 : 1 | 8.000 | 3.76 |                   | ↓          |
| 99.SP.A14 | ER-20 Ø1÷13 | -         | 65 |    | 17 | 1 : 1 | 8.000 | 3.77 |                   | ↓          |

Vedi pagine compatibilità 5.14 / 5.20 - See compatibility pages 5.14 / 5.20

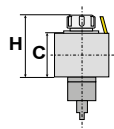

## ASSIALE AXIAL

SCAN IT TO SEE



THE TECHNICAL SHEETS

| Code      | Output      | Int Cool. | H    | C    | Nm | Ratio | Rpm   | Kg | Sense of Rotation | Tech. Draw |
|-----------|-------------|-----------|------|------|----|-------|-------|----|-------------------|------------|
| 99.SP.A09 | ER-25 Ø1+16 | -         | 73.5 | 59,5 | 10 | 1 : 1 | 6.000 | 2  |                   |            |
| 99.SP.A11 | ER-25 Ø1+16 | • 80 bar  | 73.5 | 59,5 | 10 | 1 : 1 | 6.000 | 2  |                   |            |

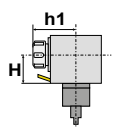

## RADIALE RADIAL

| Code      | Output      | Int Cool. | H  | h1   | Nm | Ratio | Rpm   | Kg | Sense of Rotation | Tech. Draw |
|-----------|-------------|-----------|----|------|----|-------|-------|----|-------------------|------------|
| 99.SP.A10 | ER-25 Ø1+16 | -         | 85 | 63,3 | 10 | 1 : 1 | 6.000 | 4  |                   |            |
| 99.SP.A12 | ER-25 Ø1+16 | • 80 bar  | 75 | 63,3 | 10 | 1 : 1 | 6.000 | 4  |                   |            |

TAIWAN

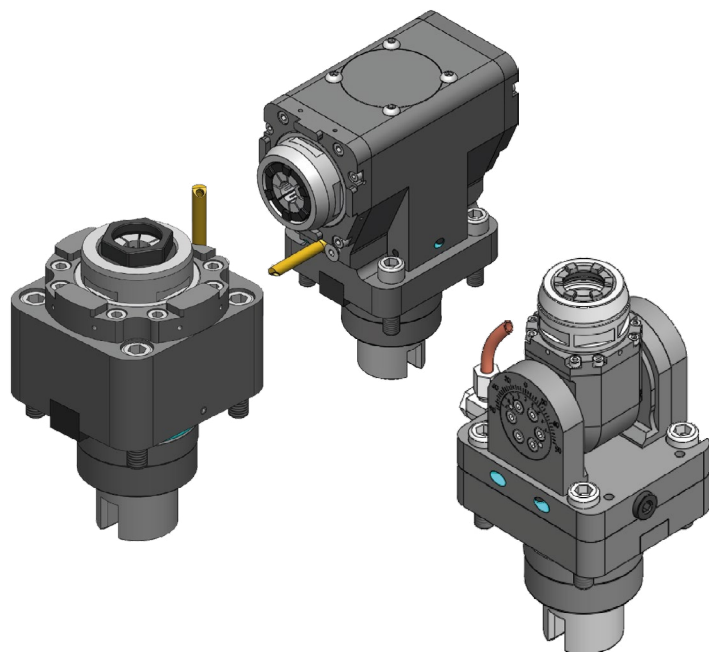

### DOTAZIONE STANDARD STANDARD EQUIPMENT



Chiave bloccaggio albero / ugello refrigerazione / vite bloccaggio ugello / viti bloccaggio motorizzato O-ring

Tool shaft lock wrench / cooling nozzle / nozzle lock screws / Driven tool locking screws / O-ring

### CAMBI RAPIDI MODULARI MODULAR QUICK CHANGE



Facile e veloce sistema modulare per il cambio rapido delle diverse tipologie di portautensili con la sede per pinza ER (DIN6499).

Modular toolholder system for the fitting of toolholders in a spindle unit with ER collets (DIN6499) outputs.

Il valore della coppia, espresso in Nm, è il massimo consentito. Per una maggiore durata, si consiglia di mantenerlo sotto tale soglia  
The torque value, expressed in Nm, is the maximum allowed. For longer life, it is recommended to keep it below this limit

| Type  | d  | d1 | d2 | f  | f1 | f3    | h1 | h2 | i1 | t  | t1 |
|-------|----|----|----|----|----|-------|----|----|----|----|----|
| BMT60 | 60 | 40 | 10 | 10 | 70 | 15-20 | 75 | 45 | 70 | 10 | 19 |

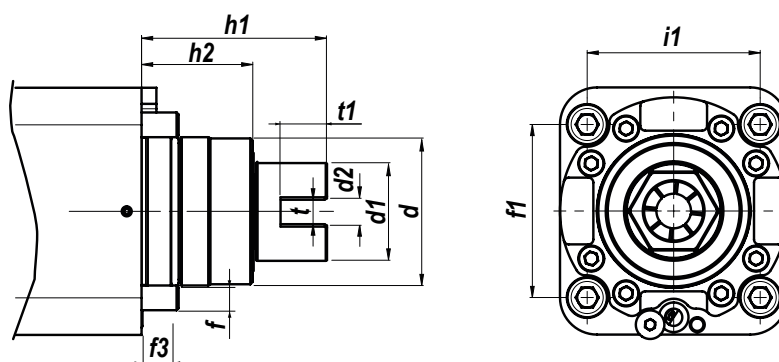

IN FASE D'ORDINE SPECIFICARE - IN CASE OF ORDER PLEASE SPECIFY:  
costruttore, modello e numero posizioni in torretta - machine builder, model and turret position numbers

## ASSIALE - AXIAL

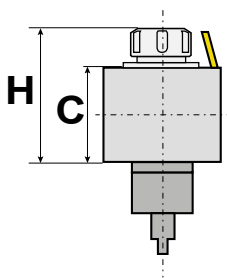
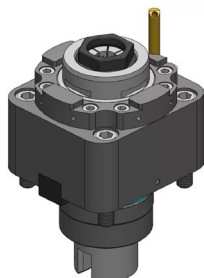

L'asse dell'utensile è in linea all'asse della torretta o del mandrino

The tool axis is aligned to the turret or spindle axis

## RADIALE - RADIAL

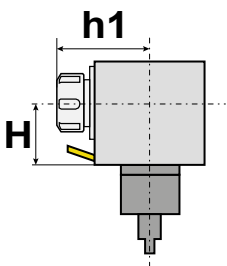
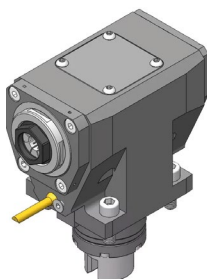

L'asse dell'utensile è perpendicolare all'asse della torretta o del mandrino

The tool axis is perpendicular to the turret or spindle axis

## RADIALE DOPPIO - DOUBLE RADIAL

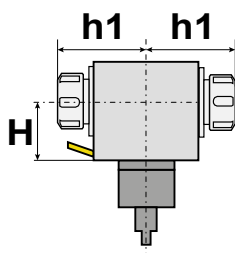
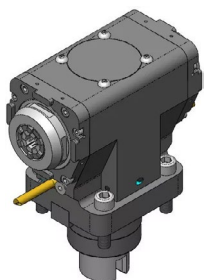

Il motorizzato ha due uscite situate sullo stesso asse radiale, ma rivolte in direzioni opposte

The driven tool has two outputs situated on the same radial axis, but facing in opposite directions

## ORIENTABILE - ADJUSTABLE

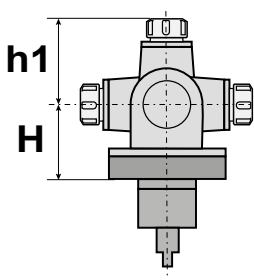
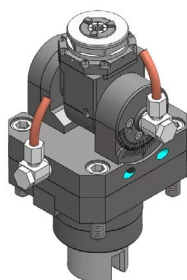

Permettono di inclinare l'asse dell'utensile secondo un angolo specifico richiesto dalla lavorazione

They allow the tool axis to be tilted to a specific angle required for the machining operation

MODELLI DI TORNIO COMPATIBILI  
 COMPATIBLE LATHE TYPES

Takisawa Taiwan

Vedi pagine compatibilità 5.14 / 5.20 - See compatibility pages 5.14 / 5.20

SCAN IT TO SEE



THE TECHNICAL SHEETS

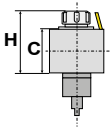

## ASSIALE AXIAL

| Code      | Output      | Int Cool. | H  | C  | Nm | Ratio | Rpm   | Kg | Sense of Rotation | Tech. Draw |
|-----------|-------------|-----------|----|----|----|-------|-------|----|-------------------|------------|
| 99.TK.A03 | ER-32 Ø2÷20 | -         | 93 | 70 | 60 | 1 : 1 | 6.000 |    |                   |            |

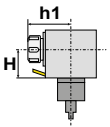

## RADIALE RADIAL

| Code      | Output      | Int Cool. | H  | h1 | Nm | Ratio | Rpm   | Kg | Sense of Rotation | Tech. Draw |
|-----------|-------------|-----------|----|----|----|-------|-------|----|-------------------|------------|
| 99.TK.A02 | ER-32 Ø2÷20 | -         | 90 | 88 | 50 | 1 : 1 | 6.000 |    |                   |            |
| 99.TK.A05 | ER-32 Ø2÷20 | • 80 bar  | 90 | 88 | 50 | 1 : 1 | 6.000 |    |                   |            |

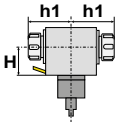

## RADIALE DOPPIO RADIAL DOUBLE

| Code      | Output      | Int Cool. | H  | h1 | Nm | Ratio | Rpm   | Kg | Sense of Rotation | Tech. Draw |
|-----------|-------------|-----------|----|----|----|-------|-------|----|-------------------|------------|
| 99.TK.A08 | ER-25 Ø1÷16 | -         | 90 | 85 | 50 | 1 : 1 | 8.000 |    |                   |            |
| 99.TK.A04 | ER-32 Ø2÷20 | -         | 90 | 88 | 50 | 1 : 1 | 8.000 |    |                   |            |
| 99.TK.A09 | ER-25 Ø1÷16 | -         | 90 | 73 | 40 | 1 : 1 | 6.000 |    |                   |            |

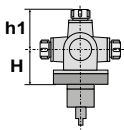

## ORIENTABILE ADJUSTABLE

| Code      | Output      | Int Cool. | H  | h1    | Nm | Ratio | Rpm   | Kg | Sense of Rotation | Tech. Draw |
|-----------|-------------|-----------|----|-------|----|-------|-------|----|-------------------|------------|
| 99.TK.A10 | ER-16 Ø1÷10 | • 80 bar  | 65 | 114,5 | 20 | 1 : 1 | 6.000 |    |                   |            |
| 99.TK.A01 | ER-25 Ø1÷16 | -         | 65 | 130   | 25 | 1 : 1 | 6.000 |    |                   |            |

**ER** Portapinza  
Collet Holder

**PF** Portafresa  
Shell Mill Holder

 Uguale al Mandrino  
Same as Spindle

 Opposto al Mandrino  
Opposite as Spindle

 Refrigerante Interno  
Internal Coolant

 Scarica il PDF  
PDF Download

**HIGH PERF.**

SCARICA  
IL CAPITOLO  
DOWNLOAD  
THE CHAPTER !!



**NUOVI MOTORIZZATI POTENZIATI DISPONIBILI !!**  
**NEW UPGRADED DRIVEN TOOLS AVAILABLE !!**

# HIGH PERFORMANCE

**Elevata coppia e 12.000 Rpm per lavorazioni a secco!**

High torque and 12.000 Rpm for dry running!



## MASSIME PRESTAZIONI E PROGETTAZIONE OTTIMIZZATA

Maximum Performance and Optimised Design

- Progettazione ottimizzata nella struttura e nei cuscinetti
- Migliori performance in fresatura e foratura
- Albero principale esente da usura
- Optimized design in the structure and bearings
- Better performance in milling and drilling
- Wear-free main shaft



## EFFICIENZA TERMICA E MANUTENZIONE SEMPLIFICATA

Thermal efficiency and simplified maintenance

- Ridotto incremento delle temperature
- Tenuta meccanica senza guarnizione
- Montaggio smontaggio semplificati
- Intervalli di manutenzione ridotti
- Reduced increase in temperatures
- Mechanical seal without gasket
- Simplified assembly and disassembly
- Reduced maintenance intervals



## POSSIBILITÀ DI LAVORARE A SECCO

Dry running available

- Possibilità di lavorare a secco ad alte velocità (ma con valori ridotti del 70%)
- Continuo miglioramento della tecnologia di tenuta
- Possibility of dry running at high speeds (but with values reduced by 70%)
- Continuous improvement of sealing technology



## CHIAVE DI BLOCCAGGIO CON SISTEMA "SENZA MANI"

'Hands-free' locking wrench

- La chiave di bloccaggio dell'albero portapinzza rimane fissa liberando una mano per un migliore serraggio dell'utensile
- Ridotto il tempo operativo di attrezzaggio
- The collet holder shaft locking key remains fixed, freeing one hand for better tightening of the tool
- Reduced operating time when tooling up the machine.

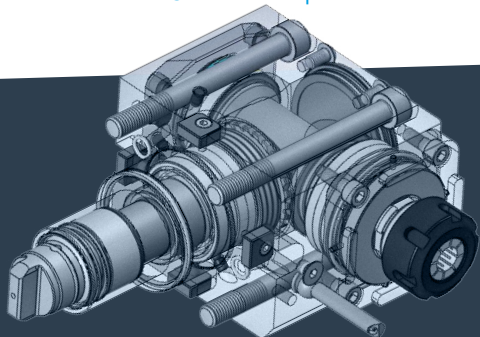

**Scansiona il QR Code per scaricare il capitolo e contatta il tuo Agente di zona!!**

Scan the QR Code to download the chapter and contact your local agent!

# PRECISION TSUGAMI



BMT 65



### DOTAZIONE STANDARD STANDARD EQUIPMENT



Chiave bloccaggio albero / ugello refrigerazione / vite bloccaggio ugello / viti bloccaggio motorizzato O-ring

Tool shaft lock wrench / cooling nozzle / nozzle lock screws / Driven tool locking screws / O-ring

### CAMBI RAPIDI MODULARI MODULAR QUICK CHANGE



Facile e veloce sistema modulare per il cambio rapido delle diverse tipologie di portautensili con la sede per pinza ER (DIN6499).

Modular toolholder system for the fitting of toolholders in a spindle unit with ER collets (DIN6499) outputs.

Il valore della coppia, espresso in Nm, è il massimo consentito. Per una maggiore durata, si consiglia di mantenerlo sotto tale soglia  
The torque value, expressed in Nm, is the maximum allowed. For longer life, it is recommended to keep it below this limit

| Type  | d  | d1 | d2 | f  | f1 | i1 | i2 | i3 | h1    | h2 | h3 | t    | t1   |
|-------|----|----|----|----|----|----|----|----|-------|----|----|------|------|
| BMT65 | 65 | 60 | 37 | 10 | 20 | 72 | 66 | 39 | 106,5 | 77 | 45 | 18,1 | 29,5 |

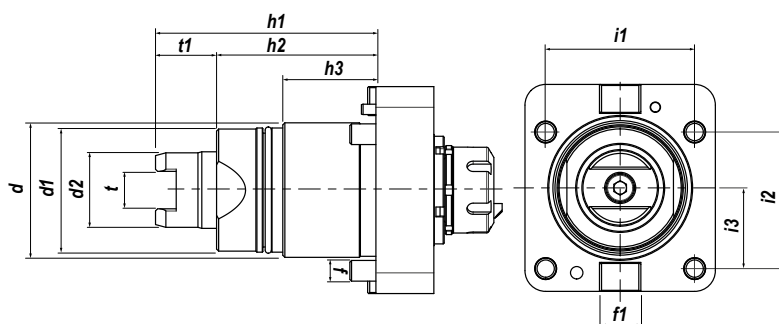

IN FASE D'ORDINE SPECIFICARE - IN CASE OF ORDER PLEASE SPECIFY:  
costruttore, modello e numero posizioni in torretta - machine builder, model and turret position numbers

## ASSIALE - AXIAL

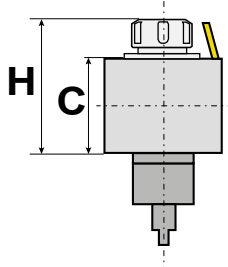
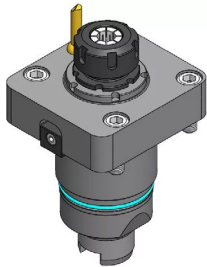

L'asse dell'utensile è in linea all'asse della torretta o del mandrino

The tool axis is aligned to the turret or spindle axis

## RADIALE - RADIAL

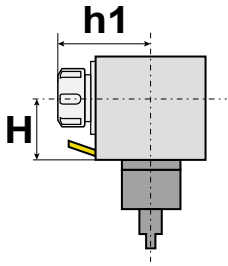
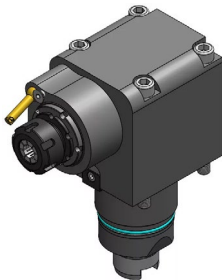

L'asse dell'utensile è perpendicolare all'asse della torretta o del mandrino

The tool axis is perpendicular to the turret or spindle axis

## RADIALE ARRETRATO - RADIAL REAR OFFSET

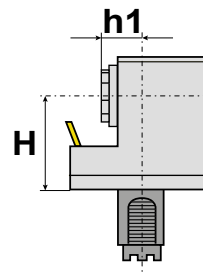
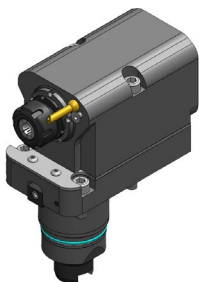

L'asse dell'utensile è perpendicolare all'asse della torretta o del mandrino ma traslato verso il corpo del motorizzato

The tool axis is perpendicular to the axis of the turret or spindle but offset towards the motorised unit

## RADIALE DOPPIO ARRETRATO - RADIAL DOUBLE OFFSET

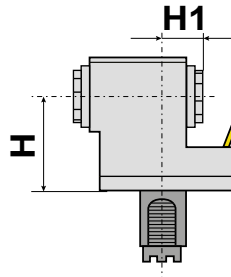
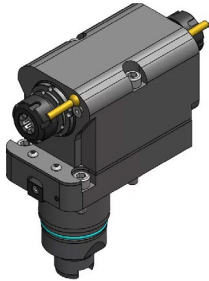

Le due uscite sono spostate all'indietro rispetto all'asse centrale del gambo

The two outputs are set back from the central axis of the stem

## ORIENTABILE - ADJUSTABLE

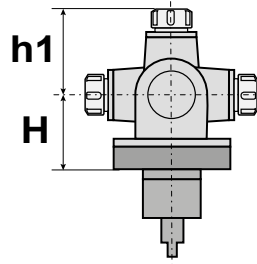
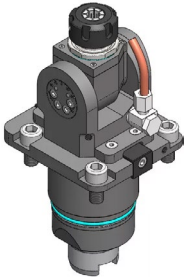

Permettono di inclinare l'asse dell'utensile secondo un angolo specifico richiesto dalla lavorazione

They allow the tool axis to be tilted to a specific angle required for the machining operation

## RADIALE DOPPIO 2 USCITE SU ASSE Y - DOUBLE RADIAL 2 OUTPUTS ON Y AXIS

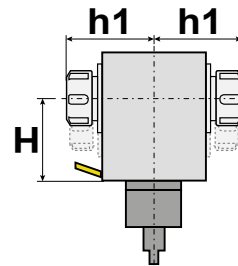
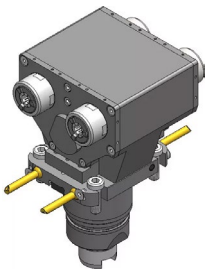

Due coppie di uscite parallele tra loro e distanziate lungo l'asse Y della macchina

Two pairs of outputs arranged in parallel and spaced apart along the machine's Y-axis

MODELLI DI TORNIO COMPATIBILI  
 COMPATIBLE LATHE TYPES

Tsugami

Vedi pagine compatibilità 5.10 / 5.16 - See compatibility pages 5.10 / 5.16

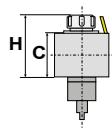

## ASSIALE AXIAL

SCAN IT TO SEE



THE TECHNICAL SHEETS

| Code      | Output      | Int Cool. | H    | C    | Nm | Ratio | Rpm   | Kg | Sense of Rotation | Tech. Draw |
|-----------|-------------|-----------|------|------|----|-------|-------|----|-------------------|------------|
| 99.TS.A01 | ER-25 Ø1+16 | -         | 62.9 | 28   | 40 | 1 : 1 | 8.000 | 4  |                   |            |
| 99.TS.A03 | ER-32 Ø2+20 | -         | 67   | 28   | 40 | 1 : 1 | 8.000 | 5  |                   |            |
| 99.TS.A02 | ER-25 Ø1+16 | • 10 bar  | 63   | 36,5 | 40 | 1 : 1 | 8.000 | 4  |                   |            |
| 99.TS.A04 | ER-32 Ø2+20 | • 10 bar  | 71   |      | 40 | 1 : 1 | 8.000 | 5  |                   |            |

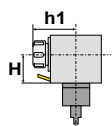

## RADIALE RADIAL

| Code      | Output      | Int Cool. | H  | h1    | Nm | Ratio | Rpm   | Kg | Sense of Rotation | Tech. Draw |
|-----------|-------------|-----------|----|-------|----|-------|-------|----|-------------------|------------|
| 99.TS.A08 | ER-25 Ø1+16 | -         | 65 | 119,9 | 40 | 1 : 1 | 8.000 | 9  |                   |            |
| 99.TS.A10 | ER-32 Ø2+20 | -         | 65 | 122   | 40 | 1 : 1 | 8.000 | 10 |                   |            |
| 99.TS.A14 | ER-32 Ø2+20 | -         | 65 | 120   | 40 | 1 : 1 | 8.000 | 10 |                   |            |
| 99.TS.A09 | ER-25 Ø1+16 | • 100 bar | 69 | 120   | 40 | 1 : 1 | 8.000 | 10 |                   |            |
| 99.TS.A11 | ER-32 Ø2+20 | • 100 bar | 65 | 122,1 | 40 | 1 : 1 | 8.000 | 10 |                   |            |
| 99.TS.A15 | ER-32 Ø2+20 | • 100 bar | 85 | 121   | 40 | 1 : 1 | 8.000 | 10 |                   |            |
| 99.TS.A16 | ER-32 Ø2+20 | -         | 85 |       | 40 | 1 : 1 | 8.000 | 10 |                   |            |

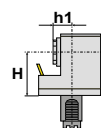

## RADIALE ARRETRATO RADIAL OFFSET

| Code      | Output      | Int Cool. | H  | h1 | Nm | Ratio | Rpm   | Kg | Sense of Rotation | Tech. Draw |
|-----------|-------------|-----------|----|----|----|-------|-------|----|-------------------|------------|
| 99.TS.A17 | ER-25 Ø1+16 | -         | 85 |    | 40 | 1 : 1 | 8.000 | 12 |                   |            |
| 99.TS.A18 | ER-25 Ø1+16 | • 100 bar | 85 |    | 40 | 1 : 1 | 8.000 | 13 |                   |            |

**ER** Portapinza  
Collet Holder

**PF** Portafresa  
Shell Mill Holder

 Ugualo al Mandrino  
Same as Spindle

 Opposto al Mandrino  
Opposite as Spindle

 Refrigerante Interno  
Internal Coolant

 Scarica il PDF  
PDF Download

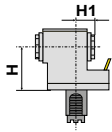

## RADIALE DOPPIO ARRETRATO

### RADIAL DOUBLE OFFSET



| Code      | Output      | Int Cool. | H  | h1   | Nm | Ratio | Rpm   | Kg | Sense of Rotation | Tech. Draw |
|-----------|-------------|-----------|----|------|----|-------|-------|----|-------------------|------------|
| 99.TS.A21 | ER-25 Ø1÷16 | -         | 85 | 61,4 | 40 | 1 : 1 | 8.000 | 13 |                   | ↓          |
| 99.TS.A22 | ER-32 Ø2÷20 | -         | 85 | 38,4 | 40 | 1 : 1 | 8.000 | 12 |                   | ↓          |

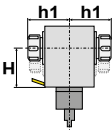

## RADIALE DOPPIO 2 USCITE SU ASSE Y

### DOUBLE RADIAL 2 OUTPUTS ON Y AXIS

| Code      | Output      | Int Cool. | H  | h1   | Nm | Ratio | Rpm   | Kg | Sense of Rotation | Tech. Draw |
|-----------|-------------|-----------|----|------|----|-------|-------|----|-------------------|------------|
| 99.TS.A23 | ER-20 Ø1÷13 | -         | 90 | 63,5 | 40 | 1 : 1 | 6.000 | 12 |                   | ↓          |

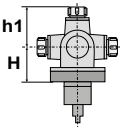

## ORIENTABILE

### ADJUSTABLE

| Code      | Output      | Int Cool. | H  | h1 | Nm | Ratio | Rpm   | Kg | Sense of Rotation | Tech. Draw |
|-----------|-------------|-----------|----|----|----|-------|-------|----|-------------------|------------|
| 99.TS.A24 | ER-20 Ø1÷13 | -         | 65 | 59 | 15 | 1 : 1 | 8.000 | 4  |                   | ↓          |
| 99.TS.A25 | ER-20 Ø1÷13 | • 70 bar  | 65 | 59 | 15 | 1 : 1 | 8.000 | 4  |                   | ↓          |
| 99.TS.A26 | ER-16 Ø1÷10 | -         | 65 | 53 | 15 | 1 : 1 | 8.000 | 4  |                   | ↓          |
| 99.TS.A27 | ER-16 Ø1÷10 | • 80 bar  | 65 | 53 | 15 | 1 : 1 | 8.000 | 4  |                   | ↓          |



# MODULAR QUICK CHANGE ADAPTORS



COMPATIBILI CON TUTTE LE USCITE ER - COMPATIBLE WITH ALL ER OUTPUTS

## SISTEMA MODULARE MODULAR SYSTEM

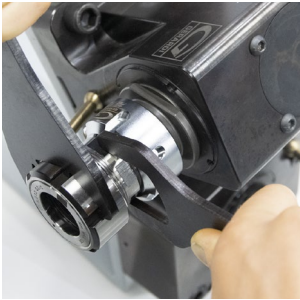

Facile e veloce sistema modulare universale per cambiare rapidamente diverse tipologie di utensili.

An easy modular system to replace quickly any tool you need.

## VANTAGGI ADVANTAGES



Aiutano a ridurre i costi-extra per l'acquisto di nuovi motorizzati o teste angolari.

The costs for further requirements of spindle units can be reduced by using the universal quick change adaptors

## ALTE PRESTAZIONI HIGH PERFORMANCE



Ghiera con cuscinetto a sfera e losanga di trascinamento removibile per una maggiore rigidità.

High rigidity thanks to the ball bearing nut and the removable diamond plate

## COMPATIBILITÀ COMPATIBILITY



Ampia gamma di uscite disponibili adatte al montaggio su qualsiasi tipologia di motorizzato o testa angolare con uscita ER

Wide range of outputs available. Ball bearing nut and removable diamond plate for highest rigidity.

I cambi rapidi modulari Gerardi mantenendo il presetting precedentemente realizzato consentono un notevole risparmio dei costi ed un ottimizzazione dei tempi ciclo. Sono perfettamente compatibili con tutti i motorizzati e le teste angolari aventi uscita ER DIN6499 e possono essere utilizzati sia con refrigerante interno che esterno.

The Gerardi modular quick change adaptors keep the tool presetting previously made and allow great costs and machining times saving. They are perfectly compatible with all driven tools and angle head with ER DIN6499 output and they can be used with internal or external coolant.

- Nuovi cambi rapidi modulari 2.0 a FORTE SERRAGGIO, 100% Made in Italy.
- Prestazioni garantite e maggior rigidità sui motorizzati Gerardi grazie alla losanga di trascinamento (rimovibile) e alla ghiera con cuscinetto a sfera.
- Adattabili a motorizzati con uscita refrigerante sia interna che esterna.
- Si consiglia di non superare i 10.000 Rpm utilizzando i cambi rapidi

- Universal HIGH TORQUE modular quick change adaptor 100% Made in Italy.
- Guaranteed higher rigidity and performances on Gerardi driven tools thanks to the removable diamond plate and the ball bearing nut
- Suitable for ER toolholder with external and internal coolant supply
- Using the quick change adaptors, we suggest not to exceed 10.000 Rpm



Vedi Pagine 7.14 - 7.15 - See pages 7.14 - 7.15



ER OUTPUTS COMPATIBLE



2 YEARS GUARANTEED



100% MADE IN ITALY

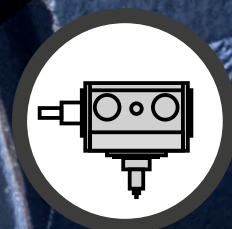

# **STOZZATORE MOTORIZZATO** **MOTORIZED SLOTTER**

*Potenzia ed aggiorna il tuo tornio*  
*Upgrade your CNC lathe*

## STOZZATORE MOTORIZZATO RADIALE RADIAL MOTORIZED SLOTTER

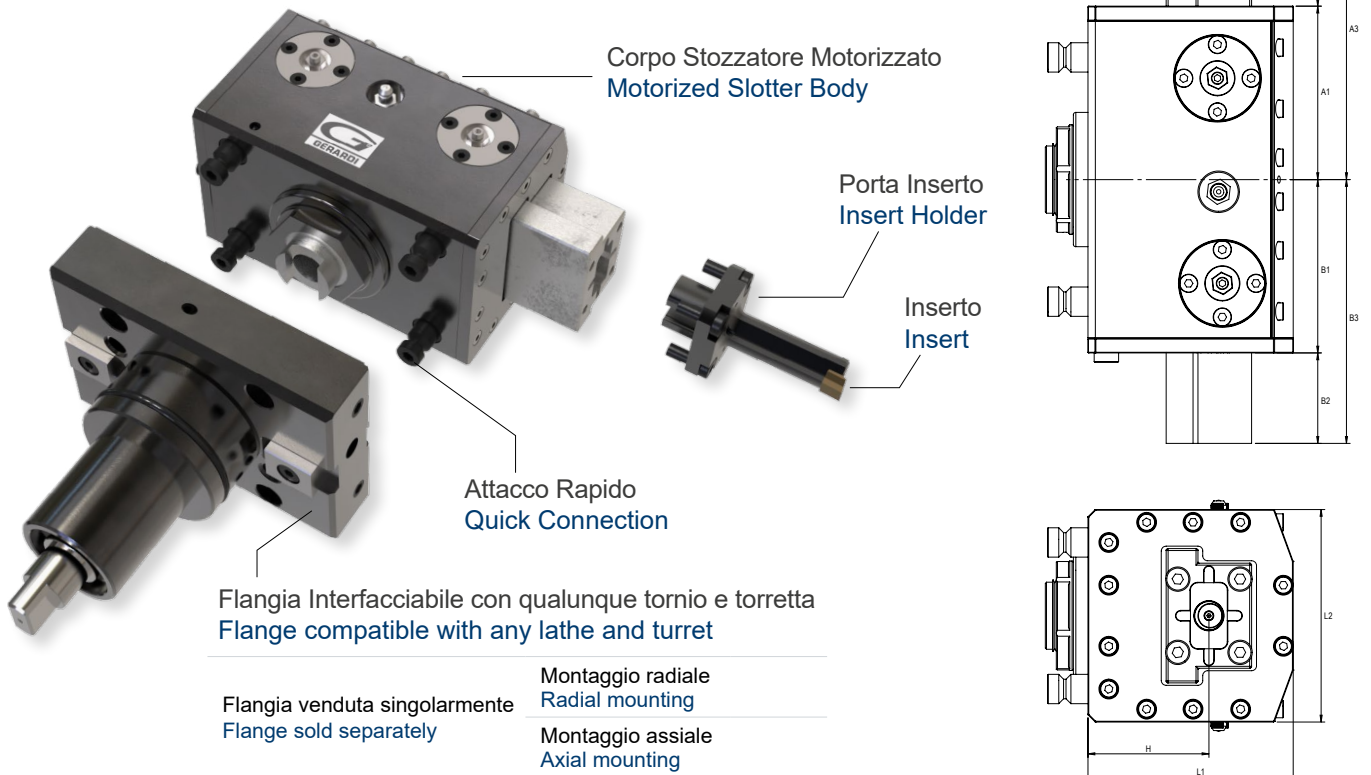

## STOZZATORE RADIALE - RADIAL MOTORIZED SLOTTER

| Cod.     | Corsa<br>Stroke | A1   | A2 | A3    | B1   | B2 | B3    | L1   | L2  | H    |
|----------|-----------------|------|----|-------|------|----|-------|------|-----|------|
| 99.ZZ.25 | 25              | 50   | 27 | 77    | 46   | 27 | 73    | 52   | 63  | 30   |
| 99.ZZ.35 | 35              | 71   | 37 | 108   | 71   | 37 | 108   | 84   | 87  | 49,5 |
| 99.ZZ.50 | 50              | 88,5 | 52 | 140,5 | 73,5 | 52 | 125,5 | 84   | 99  | 49,5 |
| 99.ZZ.65 | 65              | 101  | 67 | 168   | 76   | 67 | 76    | 87,5 | 111 | 51   |

\* I prezzi di listino si riferiscono alla versione **radiale**. La configurazione **assiale** richiede l'integrazione di una base specifica, pertanto necessita di una quotazione dedicata: contattare per maggiori informazioni.

\* List prices refer to the **radial** version. The **axial** configuration requires the integration of a specific base, so it requires a dedicated price quote: please contact us for more information.

## PARAMETRI DI TAGLIO - CUTTING PARAMETERS

### SPESSORE MASSIMO REALIZZABILE SUI VARI MATERIALI E PARAMETRI DI TAGLIO MAXIMUM THICKNESS ACHIEVABLE ON VARIOUS MATERIALS AND CUTTING PARAMETERS

|                    | Corsa 35 (mm)<br>Stroke 35 (mm) | Corsa 50 (mm)<br>Stroke 50 (mm) | Corsa 65 (mm)<br>Stroke 65 (mm) | Velocità di taglio<br>Cutting speed | Incremento (mm)<br>Increase (mm) |
|--------------------|---------------------------------|---------------------------------|---------------------------------|-------------------------------------|----------------------------------|
| ALLUMINIO          | 16                              | 16                              | 16                              | 38 m/min.                           | 0,06 / 0,15                      |
| ACCIAIO TENERO     | 14                              | 14                              | 14                              | 33 m/min.                           | 0,04 / 0,07                      |
| GHISA              | 14                              | 14                              | 12                              | 28 m/min.                           | 0,04 / 0,07                      |
| ACCIAIO COMUNE     | 14                              | 14                              | 12                              | 30 m/min.                           | 0,03 / 0,05                      |
| ACCIAIO BONIFICATO | 12                              | 12                              | 10                              | 25 m/min.                           | 0,02 / 0,04                      |
| ACCIAIO INOX       | 12                              | 12                              | 10                              | 25 m/min.                           | 0,02 / 0,04                      |
| PLASTICA           | 18                              | 18                              | 18                              | 40 m/min.                           | 0,07 / 0,15                      |
| BRONZO-OTTONE      | 14                              | 12                              | 12                              | 30 m/min.                           | 0,03 / 0,06                      |

# PORTA INSERTO INSERT HOLDER

## GR-P

SERIE GR-PM GR-PP / GR-PE / GR-PQ / GR-PS / GR-PX



|                |   |  |
|----------------|---|--|
| GR-PM<br>GR-PP | <b>Porta inserti metrici e in pollici. Serie per realizzazione sedi chiavetta interne</b><br>Metric and inch insert holder. Series for manufacturing internal key seats   |  |
| GR-PE          | <b>Porta inserti esagonali. Serie per realizzazione profili esagoni -120°</b><br>Hexagonal insert holder. Series for making hexagonal profiles -120°                      |  |
| GR-PQ          | <b>Porta inserti quadri. Serie per realizzazione profili quadri -90°</b><br>Square insert holder. Series for creating square profiles -90°                                |  |
| GR-PS          | <b>Porta inserti speciali. Serie per realizzazione profili scanalati interni/esterni</b><br>Special insert holder. Series for creating internal/external grooved profiles |  |
| GR-PX          | <b>Adattatore serie per realizzare micro lavorazioni speciali</b><br>Adapter for series for creating special micro-machining operations                                   |  |

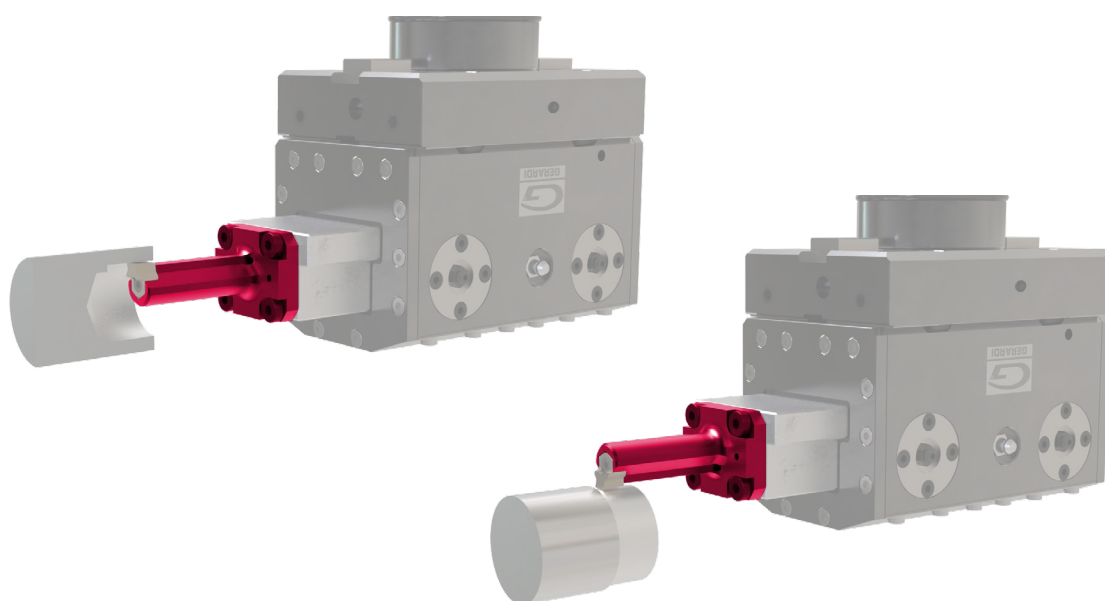

## GR-PM

Serie per realizzazione profili rettangolari interni (sedi)  
Series for creating internal rectangular profiles (seats)

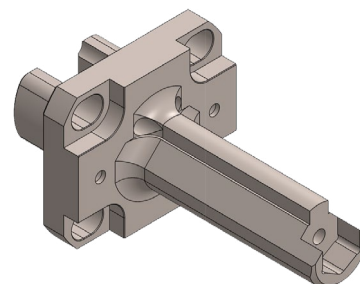
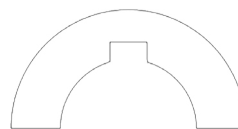
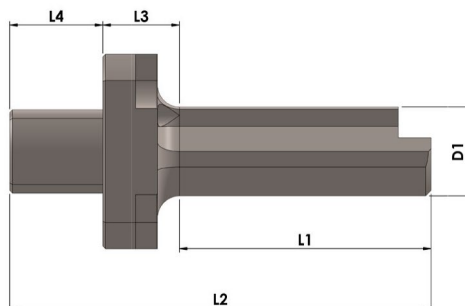
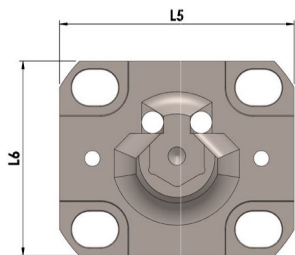

| Per corsa<br>For stroke | Cod.           | Grandezza<br>sede<br>Slot size | L1<br>(mm) | L2<br>(mm) | L3<br>(mm) | L4<br>(mm) | L5<br>(mm) | L6<br>(mm) | D1<br>(mm) | Foro<br>minimo<br>Min hole<br>(mm) | Peso<br>Weight<br>(g) |
|-------------------------|----------------|--------------------------------|------------|------------|------------|------------|------------|------------|------------|------------------------------------|-----------------------|
| <b>25</b>               | 99.ZZ.PM2-02   | 02                             | 26         | 43         | 8          | 9          | 27,5       | 19         | 6,5        | 7                                  | 26                    |
|                         | 99.ZZ.PM2-03   | 03                             | 26         | 43         | 8          | 9          | 27,5       | 19         | 8          | 8,7                                | 28                    |
|                         | 99.ZZ.PM2-04   | 04                             | 26         | 43         | 8          | 9          | 27,5       | 19         | 10         | 11                                 | 34                    |
|                         | 99.ZZ.PM2-05   | 05                             | 26         | 43         | 8          | 9          | 27,5       | 19         | 12         | 13                                 | 39                    |
|                         | 99.ZZ.PM2-06   | 06                             | 26         | 43         | 8          | 9          | 27,5       | 19         | 15         | 17                                 | 48                    |
|                         | <b>35</b>      | 99.ZZ.PM3-02                   | 02         | 25         | 56         | 14         | 17         | 43         | 35         | 6,5                                | 7                     |
| 99.ZZ.PM3-03            |                | 03                             | 30         | 61         | 14         | 17         | 43         | 35         | 7,8        | 8,7                                | 160                   |
| 99.ZZ.PM3-04            |                | 04                             | 40         | 71         | 14         | 17         | 43         | 35         | 10         | 11                                 | 170                   |
| 99.ZZ.PM3-05            |                | 05                             | 46         | 79         | 14         | 20         | 43         | 35         | 12         | 13                                 | 180                   |
| 99.ZZ.PM3-06            |                | 06                             | 46         | 79         | 14         | 20         | 43         | 35         | 16         | 17                                 | 210                   |
| 99.ZZ.PM3-08            |                | 08                             | 46         | 79         | 14         | 20         | 43         | 35         | 20         | 21,5                               | 225                   |
| 99.ZZ.PM3-1012          |                | 10/12                          | 46         | 79         | 14         | 20         | 43         | 35         | 22         | 24                                 | 235                   |
| 99.ZZ.PM3-1416          |                | 14/16                          | 46         | 79         | 14         | 20         | 43         | 35         | 25         | 27                                 | 245                   |
| <b>50</b>               | 99.ZZ.PM5-02   | 02                             | 25         | 56         | 14         | 17         | 43         | 35         | 6          | 7                                  | 150                   |
|                         | 99.ZZ.PM5-03   | 03                             | 30         | 61         | 14         | 17         | 43         | 35         | 8          | 8,7                                | 160                   |
|                         | 99.ZZ.PM5-04   | 04                             | 40         | 71         | 14         | 17         | 43         | 35         | 10         | 11                                 | 170                   |
|                         | 99.ZZ.PM5-05   | 05                             | 46         | 79         | 14         | 20         | 43         | 35         | 12         | 13                                 | 180                   |
|                         | 99.ZZ.PM5-06   | 06                             | 56         | 87         | 14         | 17         | 43         | 35         | 16         | 17                                 | 210                   |
|                         | 99.ZZ.PM5-08   | 08                             | 56         | 87         | 14         | 17         | 43         | 35         | 20         | 21,5                               | 225                   |
|                         | 99.ZZ.PM5-1012 | 10/12                          | 56         | 87         | 14         | 17         | 43         | 35         | 22         | 24                                 | 235                   |
|                         | 99.ZZ.PM5-1416 | 14/16                          | 56         | 87         | 14         | 17         | 43         | 35         | 25         | 27                                 | 245                   |
| <b>65</b>               | 99.ZZ.PM6-02   | 02                             | 25         | 56         | 14         | 17         | 43         | 35         | 6          | 7                                  | 150                   |
|                         | 99.ZZ.PM6-03   | 03                             | 30         | 61         | 14         | 17         | 43         | 35         | 8          | 8,7                                | 160                   |
|                         | 99.ZZ.PM6-04   | 04                             | 40         | 71         | 14         | 17         | 43         | 35         | 10         | 11                                 | 170                   |
|                         | 99.ZZ.PM6-05   | 05                             | 46         | 79         | 14         | 20         | 43         | 35         | 12         | 13                                 | 180                   |
|                         | 99.ZZ.PM6-06   | 06                             | 56         | 87         | 14         | 17         | 43         | 35         | 16         | 17                                 | 210                   |
|                         | 99.ZZ.PM6-08   | 08                             | 56         | 87         | 14         | 17         | 43         | 35         | 20         | 21,5                               | 225                   |
|                         | 99.ZZ.PM6-1012 | 10/12                          | 56         | 87         | 14         | 17         | 43         | 35         | 22         | 24                                 | 235                   |
|                         | 99.ZZ.PM6-1416 | 14/16                          | 56         | 87         | 14         | 17         | 43         | 35         | 25         | 27                                 | 245                   |

## GR-PE

Serie per realizzazione profili esagoni -120°  
Series for making hexagonal profiles -120°

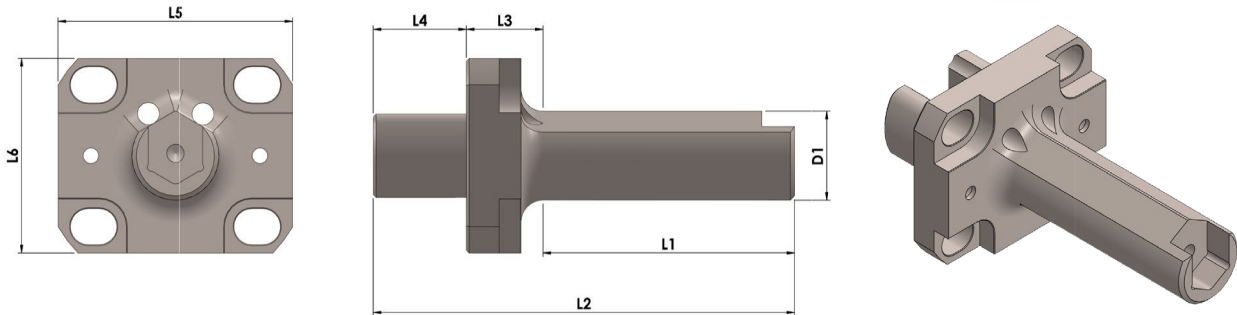

| Per corsa<br>For stroke | Cod.           | Grandezza<br>sede<br>Slot size | L1<br>(mm) | L2<br>(mm) | L3<br>(mm) | L4<br>(mm) | L5<br>(mm) | L6<br>(mm) | D1<br>(mm) | Foro<br>minimo<br>Min hole<br>(mm) | Peso<br>Weight<br>(g) |
|-------------------------|----------------|--------------------------------|------------|------------|------------|------------|------------|------------|------------|------------------------------------|-----------------------|
| <b>25</b>               | 99.ZZ.PE2-0911 | 9/11                           | 26         | 43         | 8          | 9          | 27,5       | 19         | 8          | 8,7                                | 28                    |
|                         | 99.ZZ.PE2-1117 | 11/17                          | 26         | 43         | 8          | 9          | 27,5       | 19         | 10         | 11                                 | 34                    |
|                         | 99.ZZ.PE2-1728 | 17/28                          | 26         | 43         | 8          | 9          | 27,5       | 9          | 15         | 16,5                               | 39                    |
| <b>35</b>               | 99.ZZ.PE3-0911 | 9/11                           | 30         | 61         | 14         | 17         | 43         | 35         | 8          | 8,7                                | 150                   |
|                         | 99.ZZ.PE3-1117 | 11/17                          | 35         | 66         | 14         | 17         | 43         | 35         | 10         | 11                                 | 160                   |
|                         | 99.ZZ.PE3-1728 | 17/28                          | 46         | 77         | 14         | 17         | 43         | 35         | 15         | 16                                 | 170                   |
|                         | 99.ZZ.PE3-2837 | 28/37                          | 46         | 77         | 14         | 17         | 43         | 35         | 25         | 27                                 | 180                   |
|                         | 99.ZZ.PE3-3745 | 37/45                          | 46         | 77         | 14         | 17         | 43         | 35         | 28         | 30                                 | 270                   |
| <b>50</b>               | 99.ZZ.PE5-0911 | 9/11                           | 30         | 61         | 14         | 17         | 43         | 35         | 8          | 8,7                                | 150                   |
|                         | 99.ZZ.PE5-1117 | 11/17                          | 35         | 66         | 14         | 17         | 43         | 35         | 10         | 11                                 | 160                   |
|                         | 99.ZZ.PE5-1728 | 17/28                          | 60         | 91         | 14         | 17         | 43         | 35         | 15         | 16                                 | 210                   |
|                         | 99.ZZ.PE5-2837 | 28/37                          | 60         | 91         | 14         | 17         | 43         | 35         | 25         | 27                                 | 225                   |
|                         | 99.ZZ.PE5-3745 | 37/45                          | 60         | 91         | 14         | 17         | 43         | 35         | 28         | 30                                 | 245                   |
| <b>65</b>               | 99.ZZ.PE6-0911 | 9/11                           | 30         | 61         | 14         | 17         | 43         | 35         | 8          | 8,7                                | 150                   |
|                         | 99.ZZ.PE6-1117 | 11/17                          | 35         | 66         | 14         | 17         | 43         | 35         | 10         | 11                                 | 160                   |
|                         | 99.ZZ.PE6-1728 | 17/28                          | 60         | 91         | 14         | 17         | 43         | 35         | 15         | 16                                 | 210                   |
|                         | 99.ZZ.PE6-2837 | 28/37                          | 75         | 106        | 14         | 17         | 43         | 35         | 25         | 27                                 | 225                   |
|                         | 99.ZZ.PE6-3745 | 37/45                          | 75         | 106        | 14         | 17         | 43         | 35         | 28         | 30                                 | 275                   |

## GR-PQ

Serie per realizzazione profili quadri -90°  
Series for creating square profiles -90°

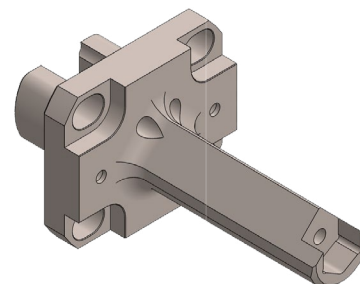
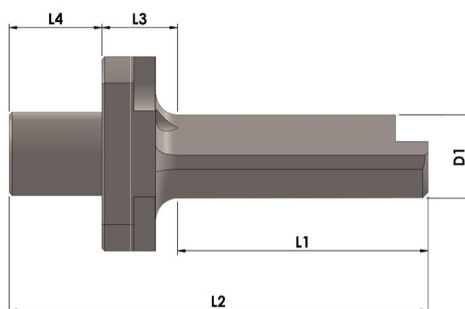
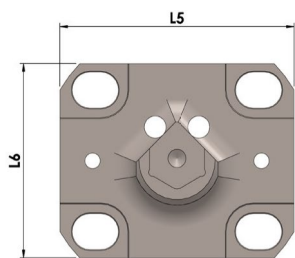

| Per corsa<br>For stroke | Cod.           | Grandezza<br>sede<br>Slot size | L1<br>(mm) | L2<br>(mm) | L3<br>(mm) | L4<br>(mm) | L5<br>(mm) | L6<br>(mm) | D1<br>(mm) | Foro<br>minimo<br>Min hole<br>(mm) | Peso<br>Weight<br>(g) |
|-------------------------|----------------|--------------------------------|------------|------------|------------|------------|------------|------------|------------|------------------------------------|-----------------------|
| 25                      | 99.ZZ.PQ2-0810 | 8/10                           | 26         | 43         | 8          | 9          | 27,5       | 19         | 7,5        | 8                                  | 28                    |
|                         | 99.ZZ.PQ2-1013 | 10/13                          | 26         | 43         | 8          | 9          | 27,5       | 19         | 8,6        | 10                                 | 34                    |
|                         | 99.ZZ.PQ2-1316 | 13/16                          | 26         | 43         | 8          | 9          | 27,5       | 19         | 12         | 13                                 | 39                    |
| 35                      | 99.ZZ.PQ3-0810 | 8/10                           | 30         | 61         | 14         | 20         | 43         | 35         | 7,25       | 8                                  | 150                   |
|                         | 99.ZZ.PQ3-1013 | 10/13                          | 40         | 66         | 14         | 20         | 43         | 35         | 8,6        | 10                                 | 160                   |
|                         | 99.ZZ.PQ3-1316 | 13/16                          | 46         | 71         | 14         | 20         | 43         | 35         | 12         | 13                                 | 170                   |
|                         | 99.ZZ.PQ3-1619 | 16/19                          | 46         | 71         | 14         | 20         | 43         | 35         | 15         | 16                                 | 180                   |
|                         | 99.ZZ.PQ3-1927 | 19/27                          | 46         | 71         | 14         | 20         | 43         | 35         | 18,5       | 19                                 | 210                   |
|                         | 99.ZZ.PQ3-2737 | 27/37                          | 46         | 71         | 14         | 20         | 43         | 35         | 25         | 27                                 | 225                   |
| 50                      | 99.ZZ.PQ5-0810 | 8/10                           | 30         | 61         | 14         | 20         | 43         | 35         | 7,25       | 8                                  | 150                   |
|                         | 99.ZZ.PQ5-1013 | 10/13                          | 40         | 66         | 14         | 20         | 43         | 35         | 8,6        | 10                                 | 160                   |
|                         | 99.ZZ.PQ5-1316 | 13/16                          | 50         | 81         | 14         | 20         | 43         | 35         | 12         | 13                                 | 170                   |
|                         | 99.ZZ.PQ5-1619 | 16/19                          | 52         | 83         | 14         | 20         | 43         | 35         | 15         | 16                                 | 180                   |
|                         | 99.ZZ.PQ5-1927 | 19/27                          | 52         | 83         | 14         | 20         | 43         | 35         | 18,5       | 19                                 | 225                   |
|                         | 99.ZZ.PQ5-2737 | 27/37                          | 60         | 91         | 14         | 20         | 43         | 35         | 25         | 27                                 | 285                   |
| 65                      | 99.ZZ.PQ6-0810 | 8/10                           | 30         | 61         | 14         | 20         | 43         | 35         | 7,25       | 8                                  | 150                   |
|                         | 99.ZZ.PQ6-1013 | 10/13                          | 40         | 66         | 14         | 20         | 43         | 35         | 8,6        | 10                                 | 160                   |
|                         | 99.ZZ.PQ6-1316 | 13/16                          | 50         | 81         | 14         | 20         | 43         | 35         | 12         | 13                                 | 170                   |
|                         | 99.ZZ.PQ6-1619 | 16/19                          | 52         | 83         | 14         | 20         | 43         | 35         | 15         | 16                                 | 210                   |
|                         | 99.ZZ.PQ6-1927 | 19/27                          | 75         | 106        | 14         | 20         | 43         | 35         | 18,5       | 19                                 | 290                   |
|                         | 99.ZZ.PQ6-2737 | 27/37                          | 75         | 106        | 14         | 20         | 43         | 35         | 25         | 27                                 | 315                   |

## GR-PS

Serie per realizzazione profili scanalati interni/esterni  
Series for creating internal/external grooved profiles

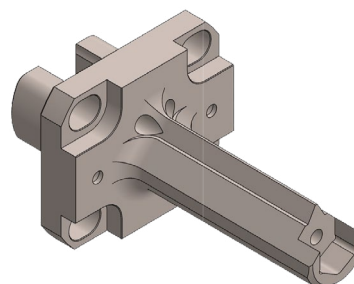
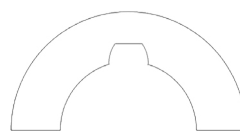
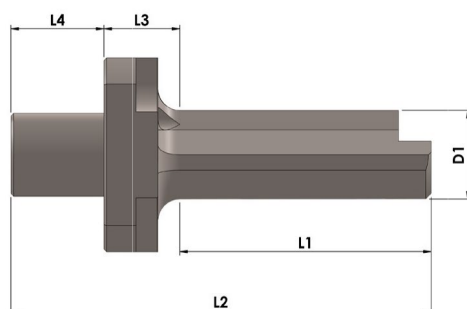
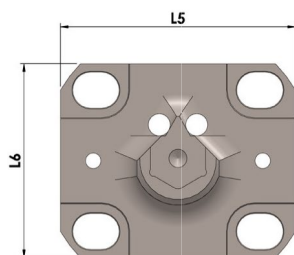

| Per corsa<br>For stroke | Cod.           | Grandezza<br>sede<br>Slot size | L1<br>(mm) | L2<br>(mm) | L3<br>(mm) | L4<br>(mm) | L5<br>(mm) | L6<br>(mm) | D1<br>(mm) | Foro<br>minimo<br>Min hole<br>(mm) | Peso<br>Weight<br>(g) |
|-------------------------|----------------|--------------------------------|------------|------------|------------|------------|------------|------------|------------|------------------------------------|-----------------------|
| <b>25</b>               | 99.ZZ.PS2-02   | 02                             | 26         | 43         | 8          | 9          | 27,5       | 19         | 6,5        | 7                                  | 26                    |
|                         | 99.ZZ.PS2-03   | 03                             | 26         | 43         | 8          | 9          | 27,5       | 19         | 7,8        | 8,7                                | 28                    |
|                         | 99.ZZ.PS2-04   | 04                             | 26         | 43         | 8          | 9          | 27,5       | 19         | 10         | 11                                 | 34                    |
|                         | 99.ZZ.PS2-05   | 05                             | 26         | 43         | 8          | 9          | 27,5       | 19         | 12         | 13                                 | 39                    |
|                         | 99.ZZ.PS2-06   | 06                             | 26         | 43         | 8          | 9          | 27,5       | 19         | 16         | 17,5                               | 48                    |
|                         | <b>35</b>      | 99.ZZ.PS3-02                   | 02         | 25         | 56         | 14         | 17         | 43         | 35         | 6,5                                | 7                     |
| 99.ZZ.PS3-03            |                | 03                             | 30         | 61         | 14         | 17         | 43         | 35         | 8          | 8,7                                | 160                   |
| 99.ZZ.PS3-04            |                | 04                             | 40         | 71         | 14         | 17         | 43         | 35         | 10         | 11                                 | 170                   |
| 99.ZZ.PS3-05            |                | 05                             | 46         | 71         | 14         | 17         | 43         | 35         | 12         | 13                                 | 180                   |
| 99.ZZ.PS3-06            |                | 06                             | 46         | 77         | 14         | 17         | 43         | 35         | 16         | 17                                 | 210                   |
| 99.ZZ.PS3-08            |                | 08                             | 46         | 77         | 14         | 17         | 43         | 35         | 20         | 21,5                               | 225                   |
| 99.ZZ.PS3-10            |                | 10                             | 46         | 77         | 14         | 17         | 43         | 35         | 22         | 24                                 | 235                   |
| 99.ZZ.PS3-12            |                | 12                             | 46         | 77         | 14         | 17         | 43         | 35         | 25         | 27                                 | 245                   |
| 99.ZZ.PS3-1416          |                | 14/16                          | 46         | 77         | 14         | 17         | 43         | 35         | 28         | 30                                 | 245                   |
| <b>50</b>               |                | 99.ZZ.PS5-02                   | 02         | 25         | 56         | 14         | 17         | 43         | 35         | 6,5                                | 7                     |
|                         | 99.ZZ.PS5-03   | 03                             | 30         | 61         | 14         | 17         | 43         | 35         | 8          | 8,7                                | 160                   |
|                         | 99.ZZ.PS5-04   | 04                             | 40         | 71         | 14         | 17         | 43         | 35         | 10         | 11                                 | 170                   |
|                         | 99.ZZ.PS5-05   | 05                             | 46         | 71         | 14         | 17         | 43         | 35         | 12         | 13                                 | 180                   |
|                         | 99.ZZ.PS5-06   | 06                             | 56         | 87         | 14         | 17         | 43         | 35         | 16         | 17                                 | 210                   |
|                         | 99.ZZ.PS5-08   | 08                             | 60         | 91         | 14         | 17         | 43         | 35         | 20         | 21,5                               | 245                   |
|                         | 99.ZZ.PS5-10   | 10                             | 60         | 91         | 14         | 17         | 43         | 35         | 22         | 24                                 | 265                   |
|                         | 99.ZZ.PS5-12   | 12                             | 60         | 91         | 14         | 17         | 43         | 35         | 22         | 24                                 | 285                   |
|                         | 99.ZZ.PS5-1416 | 14/16                          | 60         | 91         | 14         | 17         | 43         | 35         | 28         | 30                                 | 310                   |
|                         | <b>65</b>      | 99.ZZ.PS6-02                   | 02         | 25         | 56         | 14         | 17         | 43         | 35         | 6,5                                | 7                     |
| 99.ZZ.PS6-03            |                | 03                             | 30         | 61         | 14         | 17         | 43         | 35         | 8          | 8,7                                | 160                   |
| 99.ZZ.PS6-04            |                | 04                             | 40         | 71         | 14         | 17         | 43         | 35         | 10         | 11                                 | 170                   |
| 99.ZZ.PS6-05            |                | 05                             | 46         | 71         | 14         | 17         | 43         | 35         | 12         | 13                                 | 180                   |
| 99.ZZ.PS6-06            |                | 06                             | 56         | 91         | 14         | 17         | 43         | 35         | 16         | 17                                 | 210                   |
| 99.ZZ.PS6-08            |                | 08                             | 70         | 101        | 14         | 17         | 43         | 35         | 20         | 21,5                               | 245                   |
| 99.ZZ.PS6-10            |                | 10                             | 75         | 106        | 14         | 17         | 43         | 35         | 22         | 24                                 | 265                   |
| 99.ZZ.PS6-12            |                | 12                             | 75         | 106        | 14         | 17         | 43         | 35         | 22         | 24                                 | 310                   |
| 99.ZZ.PS6-1416          |                | 14/16                          | 75         | 106        | 14         | 17         | 43         | 35         | 28         | 30                                 | 310                   |

## GR-PX

**Adattatore serie per realizzare micro lavorazioni speciali**  
 Adapter for series for creating special micro-machining operations

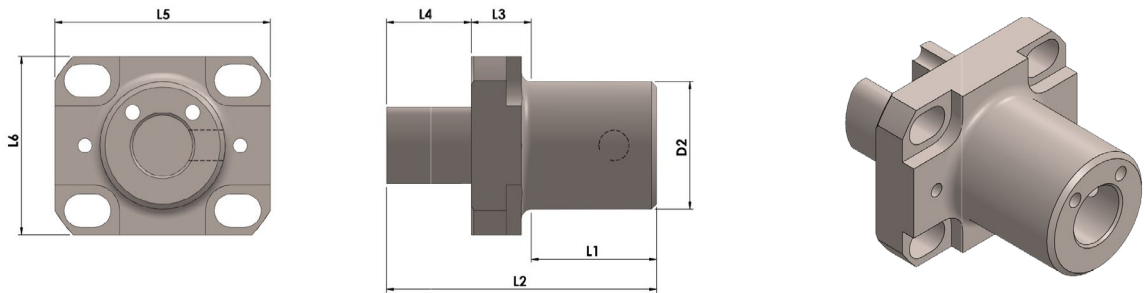

Per micro lavorazioni speciali richiedere informazioni sulla serie GR-PX e i suoi inserti. Gli inserti di questa serie possono essere utilizzati con l'adattatore UT-1/8. A loro volta, è possibile utilizzare gli UT-1/8 (come un normale utensile) per l'utilizzo su torni senza asse Y. In alternativa, gli inserti si possono bloccare nel portautensile della macchina con una semplice pinza di fissaggio (ad es. una pinza ER). In questo caso è preferibile che la macchina utensile disponga di asse Y.

For special micro machining operations, request information on the GR-PX series and its inserts. The inserts in this series can be used with the UT-1/8 adapter. In turn, the UT-1/8 can be used (as a normal tool) on lathes without a Y-axis. Alternatively, the inserts can be clamped into the machine's tool holder with a simple clamping collet (e.g. an ER collet). In this case, it is preferable for the machine tool to have a Y-axis.

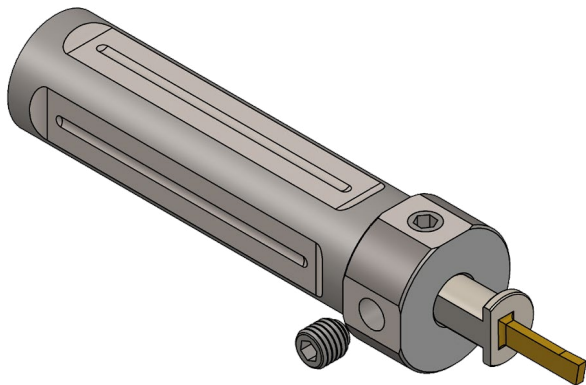

Sede chiavetta  
Key holder



Profilo quadro  
Square profile



Profilo esagonale  
Hexagonal profile



Profilo doppio quadro  
Double square profile



Profilo circolare  
Circular profile



Profilo evolvente circolare  
Circular involute profile

## ADATTATORE UT-1/8 UT-1/8 ADAPTER

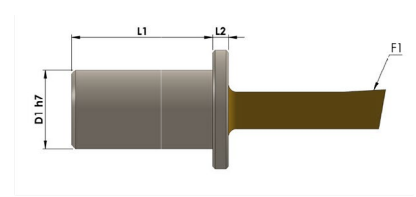
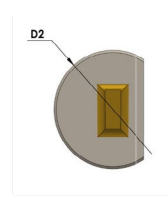
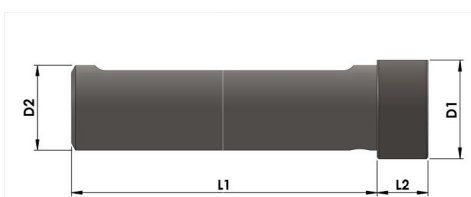

## INSERTO INTEGRALE INTEGRAL INSERT

# INSERTI INSERTS



|              |   |  |  |
|--------------|---|--|--|
| IM<br>(mm)   | <b>INSERTI<br/>PER SEDE<br/>RETTANGOLARE</b>                | Disponibili sia in lega sinterizzata realizzata dalle micro-polveri, sia in metallo duro (HM). La loro geometria consente un alto numero di riaffilature. Gli inserti la cui sigla termina con il suffisso "SM" eseguono uno smusso di 0.2x45° nel punto di intersezione tra il foro e le pareti del profilo realizzato lasciando così il foro privo di bave |  |
| IP<br>(inch) | <b>INSERTS FOR<br/>RECTANGULAR<br/>SHAPE</b>                | Available in both sintered alloy made from micro-powders and hard metal (HM). Their geometry allows for a high number of re-sharpenings. Inserts with the suffix "SM" perform a 0.2x45° chamfer at the intersection between the hole and the walls of the finished profile, leaving the hole free of burrs   |  |
| IE           | <b>INSERTI<br/>PER SEDE<br/>ESAGONALE</b>                   | Ogni misura di inserto di questa linea è in grado di realizzare diverse dimensioni di esagoni  |  |
|              | <b>INSERTS FOR<br/>HEXAGONAL<br/>SHAPE</b>                  | Each insert size in this line can produce different hexagon sizes  |  |
| IQ           | <b>INSERTI PER<br/>SEDE QUADRATA</b>                        | Ogni misura di inserto di questa linea è in grado di realizzare diverse dimensioni di quadri   |  |
|              | <b>INSERTS FOR<br/>SQUARE SHAPE</b>                         | Each insert size in this line can be used to create different frame sizes  |  |
| IS           | <b>INSERTI PER<br/>REALIZZARE<br/>PROFILI<br/>SCANALATI</b> | Gli inserti da utilizzare sulla linea di porta inserti per profili scanalati sono tutti considerati speciali: vengono prodotti appositamente in riferimento alla normativa o al dimensionamento richiesto.   |  |
|              | <b>INSERTS FOR<br/>CREATING<br/>GROOVED<br/>PROFILES</b>    | The inserts to be used on the grooved profile insert line are all considered special: they are manufactured specifically in reference to the regulations or the required dimensions.   |  |

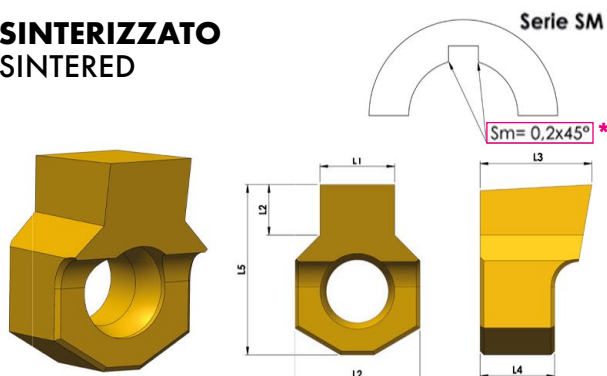
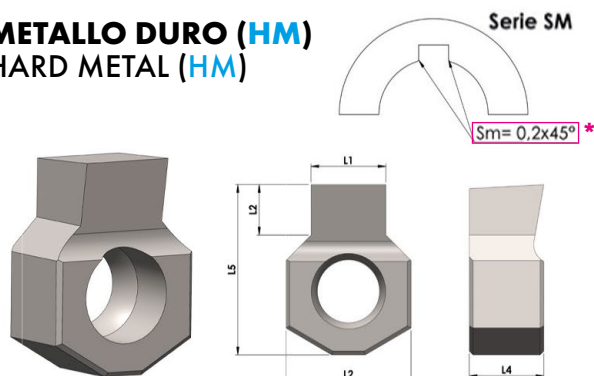

**INSERTI PER SEDE RETTANGOLARE (mm)**  
**INSERTS FOR RECTANGULAR SHAPE (mm)**
**SINTERIZZATO**  
**SINTERED**

**METALLO DURO (HM)**  
**HARD METAL (HM)**

Disponibili anche inserti in **METALLO DURO** (ex: GR-INM2-P9/HM)  
 HARD METAL inserts are also available (e.g. GR-INM2-P9/HM)

| Cod.  | Tolleranza<br>Tolerance | Tipo<br>Type | L1<br>(mm) | L2<br>(mm) | L3<br>(mm) | L4<br>(mm) | L5<br>(mm) | L6<br>(mm) | Compatibile<br>solo con serie<br>Compatible only<br>with series |
|--|-------------------------|--------------|------------|------------|------------|------------|------------|------------|---|
| GR-INM2-P9   | P9                      | 02           | 1,994      | 5          | 6,5        | 5          | 6          | 1,3        | PM  |
| GR-INM2-P9SM*  | P9-SM                   | 02           | 1,994      | 5          | 6,5        | 5          | 6          | 1,09       | PM  |
| GR-INM2-H7   | H7                      | 02           | 2,01       | 5          | 6,5        | 5          | 6          | 1,3        | PM  |
| GR-INM2-H7SM*  | H7-SM                   | 02           | 2,01       | 5          | 6,5        | 5          | 6          | 1,09       | PM  |
| GR-INM2-D10  | D10                     | 02           | 2,06       | 5          | 6,5        | 5          | 6          | 1,3        | PM  |
| GR-INM2-C11  | C11                     | 02           | 2,12       | 5          | 6,5        | 5          | 6          | 1,3        | PM  |
| GR-INM3-P9   | P9                      | 03           | 2,994      | 6,08       | 6,5        | 5          | 7,5        | 2          | PM  |
| GR-INM3-P9SM*  | P9-SM                   | 03           | 2,994      | 6,08       | 6,5        | 5          | 7,5        | 1,42       | PM  |
| GR-INM3-H7   | H7                      | 03           | 3,01       | 6,08       | 6,5        | 5          | 7,5        | 2          | PM  |
| GR-INM3-H7SM*  | H7-SM                   | 03           | 3,01       | 6,08       | 6,5        | 5          | 7,5        | 1,42       | PM  |
| GR-INM3-D10  | D10                     | 03           | 3,06       | 6,08       | 6,5        | 5          | 7,5        | 2          | PM  |
| GR-INM3-C11  | C11                     | 03           | 3,12       | 6,08       | 6,5        | 5          | 7,5        | 2          | PM  |
| GR-INM4-P9   | P9                      | 04           | 3,988      | 6,08       | 7          | 5          | 8          | 2,6        | PM  |
| GR-INM4-P9SM*  | P9-SM                   | 04           | 3,988      | 6,08       | 7          | 5          | 8          | 2,07       | PM  |
| GR-INM4-H7   | H7                      | 04           | 4,012      | 6,08       | 7          | 5          | 8          | 2,6        | PM  |
| GR-INM4-H7SM*  | H7-SM                   | 04           | 4,012      | 6,08       | 7          | 5          | 8          | 2,07       | PM  |
| GR-INM4-D10  | D10                     | 04           | 4,078      | 6,08       | 7          | 5          | 8          | 2,6        | PM  |
| GR-INM4-C11  | C11                     | 04           | 4,145      | 6,08       | 7          | 5          | 8          | 2,6        | PM  |
| GR-INM5-P9   | P9                      | 05           | 4,988      | 6,08       | 7          | 5          | 8          | 3          | PM  |
| GR-INM5-P9SM*  | P9-SM                   | 05           | 4,988      | 6,08       | 7          | 5          | 8          | 2,74       | PM  |
| GR-INM5-H7   | H7                      | 05           | 5,012      | 6,08       | 7          | 5          | 8          | 3          | PM  |
| GR-INM5-H7SM*  | H7-SM                   | 05           | 5,012      | 6,08       | 7          | 5          | 8          | 2,74       | PM  |
| GR-INM5-D10  | D10                     | 05           | 5,078      | 6,08       | 7          | 5          | 8          | 3          | PM  |
| GR-INM5-C11  | C11                     | 05           | 5,145      | 6,08       | 7          | 5          | 8          | 3          | PM  |

\* Per queste misure di inserti si consiglia di suddividere la lavorazione in due fasi: sgrossatura e finitura.

\* For these insert dimensions, we recommend dividing the machining process into two stages: roughing and finishing.

| Cod.  | Tolleranza<br>Tolerance | Tipo<br>Type | L1<br>(mm) | L2<br>(mm) | L3<br>(mm) | L4<br>(mm) | L5<br>(mm) | L6<br>(mm) | Compatibile<br>solo con serie<br>Compatible only<br>with series |
|--|-------------------------|--------------|------------|------------|------------|------------|------------|------------|---|
| GR-INM6-P9   | P9                      | 06           | 5,988      | 10,08      | 9          | 6          | 13,5       | 4          | PM  |
| GR-INM6-P9SM*  | P9-SM                   | 06           | 5,988      | 10,08      | 9          | 6          | 13,5       | 3,3        | PM  |
| GR-INM6-H7   | H7                      | 06           | 6,012      | 10,08      | 9          | 6          | 13,5       | 4          | PM  |
| GR-INM6-H7SM*  | H7-SM                   | 06           | 6,012      | 10,08      | 9          | 6          | 13,5       | 3,3        | PM  |
| GR-INM6-D10  | D10                     | 06           | 6,078      | 10,08      | 9          | 6          | 13,5       | 4          | PM  |
| GR-INM6-C11  | C11                     | 06           | 6,145      | 10,08      | 9          | 6          | 13,5       | 4          | PM  |
| GR-INM8-P9   | P9                      | 08           | 7,985      | 10,08      | 9          | 6          | 13,5       | 4,5        | PM  |
| GR-INM8-P9SM*  | P9-SM                   | 08           | 7,985      | 10,08      | 9          | 6          | 13,5       | 3,78       | PM  |
| GR-INM8-H7   | H7                      | 08           | 8,015      | 10,08      | 9          | 6          | 13,5       | 4,5        | PM  |
| GR-INM8-H7SM*  | H7-SM                   | 08           | 8,015      | 10,08      | 9          | 6          | 13,5       | 3,78       | PM  |
| GR-INM8-D10  | D10                     | 08           | 8,098      | 10,08      | 9          | 6          | 13,5       | 4,5        | PM  |
| GR-INM8-C11  | C11                     | 08           | 8,17       | 10,08      | 9          | 6          | 13,5       | 4,5        | PM  |
| GR-INM10-P9  | P9                      | 10           | 9,985      | 13,1       | 14         | 10         | 18,5       | 6          | PM  |
| GR-INM10-P9SM*   | P9-SM                   | 10           | 9,985      | 13,1       | 14         | 10         | 18,5       | 3,88       | PM  |
| GR-INM10-H7  | H7                      | 10           | 10,015     | 13,1       | 14         | 10         | 18,5       | 6          | PM  |
| GR-INM10-H7SM*   | H7-SM                   | 10           | 10,015     | 13,1       | 14         | 10         | 18,5       | 3,88       | PM  |
| GR-INM10-D10   | D10                     | 10           | 10,098     | 13,1       | 14         | 10         | 18,5       | 6          | PM  |
| GR-INM10-C11   | C11                     | 10           | 10,17      | 13,1       | 14         | 10         | 18,5       | 6          | PM  |
| GR-INM12-P9  | P9                      | 12           | 11,982     | 13,1       | 14         | 10         | 18,5       | 6,5        | PM  |
| GR-INM12-P9SM*   | P9-SM                   | 12           | 11,982     | 13,1       | 14         | 10         | 18,5       | 3,89       | PM  |
| GR-INM12-H7  | H7                      | 12           | 12,018     | 13,1       | 14         | 10         | 18,5       | 6,5        | PM  |
| GR-INM12-H7SM*   | H7-SM                   | 12           | 12,018     | 13,1       | 14         | 10         | 18,5       | 3,89       | PM  |
| GR-INM12-D10   | D10                     | 12           | 12,12      | 13,1       | 14         | 10         | 18,5       | 6,5        | PM  |
| GR-INM12-C11   | C11                     | 12           | 12,205     | 13,1       | 14         | 10         | 18,5       | 6,5        | PM  |
| GR-INM14-P9  | P9                      | 14           | 13,982     | 18         | 14         | 10         | 22         | 7          | PM  |
| GR-INM14-P9SM*   | P9-SM                   | 14           | 13,982     | 18         | 14         | 10         | 22         | 4,71       | PM  |
| GR-INM14-H7  | H7                      | 14           | 14,018     | 18         | 14         | 10         | 22         | 7          | PM  |
| GR-INM14-H7SM*   | H7-SM                   | 14           | 14,018     | 18         | 14         | 10         | 22         | 4,71       | PM  |
| GR-INM14-D10   | D10                     | 14           | 14,12      | 18         | 14         | 10         | 22         | 7          | PM  |
| GR-INM14-C11   | C11                     | 14           | 14,205     | 18         | 14         | 10         | 22         | 7          | PM  |
| GR-INM16-P9  | P9                      | 16           | 15,982     | 18         | 14         | 10         | 22         | 8          | PM  |
| GR-INM16-P9SM*   | P9-SM                   | 16           | 15,982     | 18         | 14         | 10         | 22         | 5,53       | PM  |
| GR-INM16-H7  | H7                      | 16           | 16,018     | 18         | 14         | 10         | 22         | 8          | PM  |
| GR-INM16-H7SM*   | H7-SM                   | 16           | 16,018     | 18         | 14         | 10         | 22         | 5,53       | PM  |
| GR-INM16-D10   | D10                     | 16           | 16,12      | 18         | 14         | 10         | 22         | 8          | PM  |
| GR-INM16-C11   | C11                     | 16           | 16,205     | 18         | 14         | 10         | 22         | 8          | PM  |
| GR-INM18-P9 <sup>▲</sup>   | P9                      | 18           | 17,982     | 26         | 18         | 10         | 30         | 5,67       | PM  |
| GR-INM18-P9SM* <sup>▲</sup>  | P9-SM                   | 18           | 17,982     | 26         | 18         | 10         | 30         | 3,9        | PM  |
| GR-INM18-H7 <sup>▲</sup>   | H7                      | 18           | 18,018     | 26         | 18         | 10         | 30         | 5,67       | PM  |
| GR-INM18-H7SM* <sup>▲</sup>  | H7-SM                   | 18           | 18,018     | 26         | 18         | 10         | 30         | 3,9        | PM  |
| GR-INM18-D10 <sup>▲</sup>  | D10                     | 18           | 18,12      | 26         | 18         | 10         | 30         | 9          | PM  |

<sup>▲</sup> Per queste misure di inserti si consiglia di suddividere la lavorazione in due fasi: sgrossatura e finitura.

<sup>▲</sup> For these insert dimensions, we recommend dividing the machining process into two stages: roughing and finishing.

| Cod.  | Tolleranza<br>Tolerance | Tipo<br>Type | L1<br>(mm) | L2<br>(mm) | L3<br>(mm) | L4<br>(mm) | L5<br>(mm) | L6<br>(mm) | Compatibile<br>solo con serie<br>Compatible only<br>with series |
|--|-------------------------|--------------|------------|------------|------------|------------|------------|------------|---|
| GR-INM20-P9▲   | P9                      | 20           | 19,978     | 26         | 18         | 10         | 30         | 6,29       | PM  |
| GR-INM20-P9SM*▲  | P9-SM                   | 20           | 19,978     | 26         | 18         | 10         | 30         | 4          | PM  |
| GR-INM20-H7▲   | H7                      | 20           | 20,021     | 26         | 18         | 10         | 30         | 6,29       | PM  |
| GR-INM20-H7SM*▲  | H7-SM                   | 20           | 20,021     | 26         | 18         | 10         | 30         | 4          | PM  |
| GR-INM22-P9▲   | P9                      | 22           | 20,149     | 26         | 18         | 10         | 30         | 10         | PM  |
| GR-INM22-P9SM*▲  | P9-SM                   | 22           | 21,978     | 26         | 18         | 10         | 30         | 6,79       | PM  |
| GR-INM22-H7▲   | H7                      | 22           | 22,021     | 26         | 18         | 10         | 30         | 11         | PM  |
| GR-INM22-H7SM*▲  | H7-SM                   | 22           | 22,021     | 26         | 18         | 10         | 30         | 6,79       | PM  |
| GR-INM22-D10▲  | D10                     | 22           | 22,149     | 26         | 18         | 10         | 30         | 11         | PM  |
| GR-INM22-C11▲  | C11                     | 22           | 22,205     | 26         | 18         | 10         | 30         | 11         | PM  |
| GR-INM25-P9▲   | P9                      | 25           | 24,978     | 26         | 18         | 10         | 30         | 7,02       | PM  |
| GR-INM25-P9SM*▲  | P9-SM                   | 25           | 24,978     | 26         | 18         | 10         | 30         | 4          | PM  |
| GR-INM25-H7▲   | H7                      | 25           | 25,021     | 26         | 18         | 10         | 30         | 7,02       | PM  |
| GR-INM25-H7SM*▲  | H7-SM                   | 25           | 25,021     | 26         | 18         | 10         | 30         | 4          | PM  |
| GR-INM25-D10▲  | D10                     | 25           | 25,149     | 26         | 18         | 10         | 30         | 12         | PM  |
| GR-INM25-C11▲  | C11                     | 25           | 25,24      | 26         | 18         | 10         | 30         | 12         | PM  |

## INSERTI PER SEDE RETTANGOLARE (pollici) INSERTS FOR RECTANGULAR SHAPE (inches)

### SINTERIZZATO SINTERED

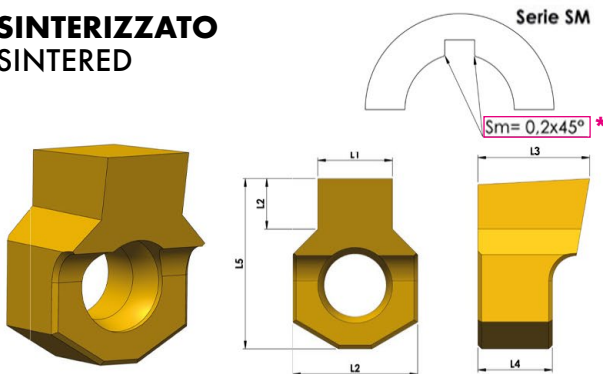

### METALLO DURO (HM) HARD METAL (HM)

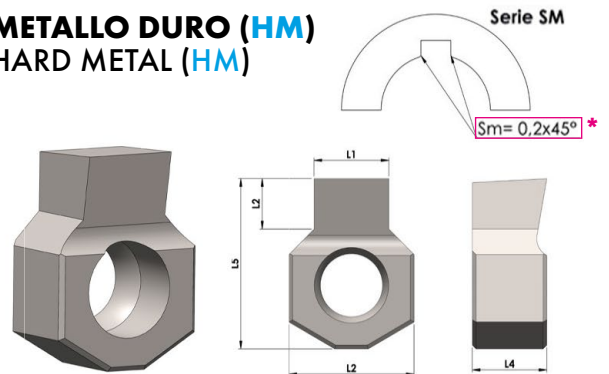

Disponibili anche inserti in METALLO DURO (ex: GR-INP2-3P32-P9/HM)  
HARD METAL inserts are also available (e.g. GR-INP2-3P32-P9/HM)

| Cod.  | Tolleranza<br>Tolerance | Tipo<br>Type | L1<br>(mm) | L1<br>(pollici) | L2<br>(pollici) | L3<br>(pollici) | L4<br>(pollici) | L5<br>(pollici) | L6<br>(pollici) | Compatibile<br>solo con serie<br>Compatible only<br>with series |
|--|-------------------------|--------------|------------|-----------------|-----------------|-----------------|-----------------|-----------------|-----------------|---|
| GR-INP2-3P32-P9  | P9                      | 3/32"        | 2,375      | 0,0935          | 0,1968          | 0,2362          | 0,1968          | 0,2559          | 0,0551          | PP  |
| GR-INP2-3P32-H7  | H7                      | 3/32"        | 2,391      | 0,0941          | 0,1968          | 0,2362          | 0,1968          | 0,2559          | 0,0551          | PP  |
| GR-INP2-3P32-D10   | D10                     | 3/32"        | 2,441      | 0,0961          | 0,1968          | 0,2362          | 0,1968          | 0,2559          | 0,0551          | PP  |
| GR-INP2-3P32-C11   | C11                     | 3/32"        | 2,501      | 0,0984          | 0,1968          | 0,2362          | 0,1968          | 0,2559          | 0,0551          | PP  |
| GR-INP3-1P8-P9   | P9                      | 1/8"         | 3,163      | 0,1241          | 0,2393          | 0,2559          | 0,1968          | 0,2952          | 0,0905          | PP  |
| GR-INP3-1P8-H7   | H7                      | 1/8"         | 3,187      | 0,1255          | 0,2393          | 0,2559          | 0,1968          | 0,2952          | 0,0905          | PP  |
| GR-INP3-1P8-D10  | D10                     | 1/8"         | 3,253      | 0,128           | 0,2393          | 0,2559          | 0,1968          | 0,2952          | 0,0905          | PP  |
| GR-INP3-1P8-C11  | C11                     | 1/8"         | 3,2        | 0,1307          | 0,2393          | 0,2559          | 0,1968          | 0,2952          | 0,0905          | PP  |

▲ Per queste misure di inserti si consiglia di suddividere la lavorazione in due fasi: sgrossatura e finitura.

▲ For these insert dimensions, we recommend dividing the machining process into two stages: roughing and finishing.

| Cod.                | Tolleranza<br>Tolerance | Tipo<br>Type | L1<br>(mm) | L1<br>(pollici) | L2<br>(pollici) | L3<br>(pollici) | L4<br>(pollici) | L5<br>(pollici) | L6<br>(pollici) | Compatibile<br>solo con serie<br>Compatible only<br>with series |
|---------------------|-------------------------|--------------|------------|-----------------|-----------------|-----------------|-----------------|-----------------|-----------------|---|
| GR-INP4-5P32-P9     | P9                      | 5/32"        | 3,969      | 0,1555          | 0,2393          | 0,2755          | 0,1968          | 0,3149          | 0,1141          | PP  |
| GR-INP4-5P32-H7     | H7                      | 5/32"        | 3,981      | 0,1567          | 0,2393          | 0,2755          | 0,1968          | 0,3149          | 0,1141          | PP  |
| GR-INP4-5P32-D10    | D10                     | 5/32"        | 4,047      | 0,1593          | 0,2393          | 0,2755          | 0,1968          | 0,3149          | 0,1141          | PP  |
| GR-INP4-5P32-C11    | C11                     | 5/32"        | 4,114      | 0,1619          | 0,2393          | 0,2755          | 0,1968          | 0,3149          | 0,1141          | PP  |
| GR-INP5-3P16-P9     | P9                      | 3/16"        | 4,751      | 0,1871          | 0,2393          | 0,2755          | 0,1968          | 0,3149          | 0,1299          | PP  |
| GR-INP5-3P16-H7     | H7                      | 3/16"        | 4,774      | 0,1879          | 0,2393          | 0,2755          | 0,1968          | 0,3149          | 0,1299          | PP  |
| GR-INP5-3P16-D10    | D10                     | 3/16"        | 4,84       | 0,1905          | 0,2393          | 0,2755          | 0,1968          | 0,3149          | 0,1299          | PP  |
| GR-INP5-3P16-C11    | C11                     | 3/16"        | 4,908      | 0,1932          | 0,2393          | 0,2755          | 0,1968          | 0,3149          | 0,1299          | PP  |
| GR-INP6-1P4-P9      | P9                      | 1/4"         | 6,335      | 0,2494          | 0,3968          | 0,3543          | 0,2362          | 0,5314          | 0,1587          | PP  |
| GR-INP6-1P4-H7      | H7                      | 1/4"         | 6,365      | 0,2505          | 0,3968          | 0,3543          | 0,2362          | 0,5314          | 0,1587          | PP  |
| GR-INP6-1P4-D10     | D10                     | 1/4"         | 6,448      | 0,2538          | 0,3968          | 0,3543          | 0,2362          | 0,5314          | 0,1587          | PP  |
| GR-INP6-1P4-C11     | C11                     | 1/4"         | 6,52       | 0,2569          | 0,3968          | 0,3543          | 0,2362          | 0,5314          | 0,1587          | PP  |
| GR-INP8-9P32-P9     | P9                      | 9/32"        | 7,129      | 0,2806          | 0,3968          | 0,3543          | 0,2362          | 0,5314          | 0,1692          | PP  |
| GR-INP8-9P32-H7     | H7                      | 9/32"        | 7,159      | 0,2818          | 0,3968          | 0,3543          | 0,2362          | 0,5314          | 0,1692          | PP  |
| GR-INP8-9P32-D10    | D10                     | 9/32"        | 7,242      | 0,2851          | 0,3968          | 0,3543          | 0,2362          | 0,5314          | 0,1692          | PP  |
| GR-INP8-9P32-C11    | C11                     | 9/32"        | 7,314      | 0,2879          | 0,3968          | 0,3543          | 0,2362          | 0,5314          | 0,1692          | PP  |
| GR-INP8-5P16-P9     | P9                      | 5/16"        | 7,922      | 0,3119          | 0,3968          | 0,3543          | 0,2362          | 0,5314          | 0,1875          | PP  |
| GR-INP8-5P16-H7     | H7                      | 5/16"        | 7,952      | 0,313           | 0,3968          | 0,3543          | 0,2362          | 0,5314          | 0,1875          | PP  |
| GR-INP8-5P16-D10    | D10                     | 5/16"        | 8,036      | 0,3163          | 0,3968          | 0,3543          | 0,2362          | 0,5314          | 0,1875          | PP  |
| GR-INP8-5P16-C11    | C11                     | 5/16"        | 8,108      | 0,3191          | 0,3968          | 0,3543          | 0,2362          | 0,5314          | 0,1875          | PP  |
| GR-INP10-3P8-P9     | P9                      | 3/8"         | 9,511      | 0,3744          | 0,5157          | 0,5511          | 0,3937          | 0,7283          | 0,25            | PP  |
| GR-INP10-3P8-H7     | H7                      | 3/8"         | 9,54       | 0,3755          | 0,5157          | 0,5511          | 0,3937          | 0,7283          | 0,25            | PP  |
| GR-INP10-3P8-D10    | D10                     | 3/8"         | 9,623      | 0,3788          | 0,5157          | 0,5511          | 0,3937          | 0,7283          | 0,25            | PP  |
| GR-INP10-3P8-C11    | C11                     | 3/8"         | 9,695      | 0,3816          | 0,5157          | 0,5511          | 0,3937          | 0,7283          | 0,25            | PP  |
| GR-INP12-7P16-P9    | P9                      | 7/16"        | 11,094     | 0,4367          | 0,5157          | 0,5511          | 0,3937          | 0,7283          | 0,25            | PP  |
| GR-INP12-7P16-H7    | H7                      | 7/16"        | 11,13      | 0,4382          | 0,5157          | 0,5511          | 0,3937          | 0,7283          | 0,25            | PP  |
| GR-INP12-7P16-D10   | D10                     | 7/16"        | 11,232     | 0,4422          | 0,5157          | 0,5511          | 0,3937          | 0,7283          | 0,25            | PP  |
| GR-INP12-7P16-C11   | C11                     | 7/16"        | 11,318     | 0,4455          | 0,5157          | 0,5511          | 0,3937          | 0,7283          | 0,25            | PP  |
| GR-INP12-1P2-P9     | P9                      | 1/2"         | 12,682     | 0,4992          | 0,5157          | 0,5511          | 0,3937          | 0,7283          | 0,3             | PP  |
| GR-INP12-1P2-H7     | H7                      | 1/2"         | 12,718     | 0,5007          | 0,5157          | 0,5511          | 0,3937          | 0,7283          | 0,3             | PP  |
| GR-INP12-1P2-D10    | D10                     | 1/2"         | 12,82      | 0,5047          | 0,5157          | 0,5511          | 0,3937          | 0,7283          | 0,3             | PP  |
| GR-INP12-1P2-C11    | C11                     | 1/2"         | 12,905     | 0,508           | 0,5157          | 0,5511          | 0,3937          | 0,7283          | 0,3             | PP  |
| GR-INP1416-9P16-P9  | P9                      | 9/16"        | 14,27      | 0,5617          | 0,7086          | 0,5511          | 0,3937          | 0,8661          | 0,275           | PP  |
| GR-INP1416-9P16-H7  | H7                      | 9/16"        | 14,306     | 0,5632          | 0,7086          | 0,5511          | 0,3937          | 0,8661          | 0,275           | PP  |
| GR-INP1416-9P16-D10 | D10                     | 9/16"        | 14,408     | 0,5672          | 0,7086          | 0,5511          | 0,3937          | 0,8661          | 0,275           | PP  |
| GR-INP1416-9P16-C11 | C11                     | 9/16"        | 14,492     | 0,5705          | 0,7086          | 0,5511          | 0,3937          | 0,8661          | 0,275           | PP  |
| GR-INP1416-5P8-P9   | P9                      | 5/8"         | 15,857     | 0,6242          | 0,7086          | 0,5511          | 0,3937          | 0,8661          | 0,312           | PP  |
| GR-INP1416-5P8-H7   | H7                      | 5/8"         | 15,893     | 0,6257          | 0,7086          | 0,5511          | 0,3937          | 0,8661          | 0,312           | PP  |
| GR-INP1416-5P8-D10  | D10                     | 5/8"         | 15,995     | 0,6297          | 0,7086          | 0,5511          | 0,3937          | 0,8661          | 0,312           | PP  |
| GR-INP1416-5P8-C11  | C11                     | 5/8"         | 16,08      | 0,633           | 0,7086          | 0,5511          | 0,3937          | 0,8661          | 0,312           | PP  |
| GR-INP1825-3P4-P9▲  | P9                      | 3/4"         | 19,028     | 0,7491          | 1,024           | 0,7086          | 0,3937          | 1,181           | 0,393           | PP  |
| GR-INP1825-3P4-H7▲  | H7                      | 3/4"         | 19,071     | 0,7508          | 1,024           | 0,7086          | 0,3937          | 1,181           | 0,393           | PP  |
| GR-INP1825-3P4-D10▲ | D10                     | 3/4"         | 19,199     | 0,7558          | 1,024           | 0,7086          | 0,3937          | 1,181           | 0,393           | PP  |
| GR-INP1825-3P4-C11▲ | C11                     | 3/4"         | 19,29      | 0,7594          | 1,024           | 0,7086          | 0,3937          | 1,181           | 0,393           | PP  |

▲ Per queste misure di inserti si consiglia di suddividere la lavorazione in due fasi: sgrossatura e finitura.

▲ For these insert dimensions, we recommend dividing the machining process into two stages: roughing and finishing.

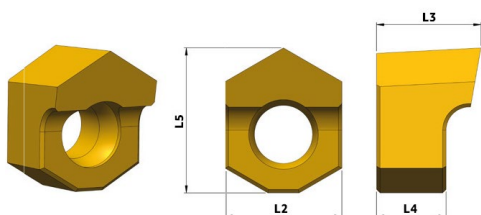
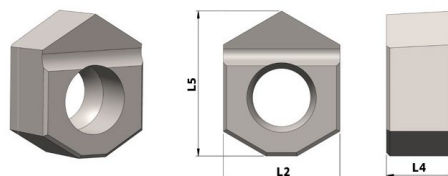
**INSERTI PER SEDE ESAGONALE - INSERTS FOR HEXAGONAL SHAPE**
**SINTERIZZATO - SINTERED**

**METALLO DURO (HM) - HARD METAL (HM)**

Disponibili anche inserti in METALLO DURO (ex: GR-INE-0911/HM)  
HARD METAL inserts are also available (e.g. GR-INE-0911/HM)

| Cod.        |  | Campo di lavoro (mm)<br>Working range (mm) | Campo di lavoro (pollici)<br>Working range (inches) | L2<br>(mm) | L3<br>(mm) | L4<br>(mm) | L5<br>(mm) | Utensile<br>Tool |
|-------------|---|--|---|------------|------------|------------|------------|------------------|
| GR-INE-0911 |   | 9mm/11mm                                   | 0,354/0,433   | 6          | 7          | 5          | 7,5        | PE-911           |
| GR-INE-1117 |   | 11mm/17mm                                  | 0,433/0,669   | 6          | 7          | 5          | 8          | PE-1117          |
| GR-INE-1728 |   | 17mm/28mm                                  | 0,669/1,102   | 10         | 9          | 6          | 13,5       | PE-1728          |
| GR-INE-2837 |   | 28mm/37mm                                  | 1,102/1,456   | 13         | 14         | 10         | 18,5       | PE-2837          |
| GR-INE-3745 |   | 37mm/45mm                                  | 1,456/1,771   | 18         | 14         | 10         | 22         | PE-3745          |

Per realizzare fori esagonali interni si deve eseguire un preforo il cui diametro è dato dalla seguente formula:

$$\text{DIAMETRO PREFORO} = \text{LATO DELL'ESAGONO} \times 1,020$$

Ad esempio, nel caso di sede esagonale con lato 10 mm il diametro del preforo sarà: 10 mm x 1,020 = 10,20 mm

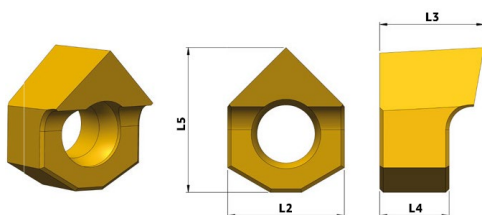
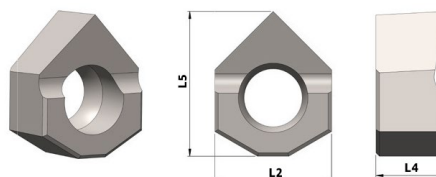
**INSERTI PER SEDE QUADRATA - INSERTS FOR SQUARE SHAPE**
**SINTERIZZATO - SINTERED**

**METALLO DURO (HM) - HARD METAL (HM)**

Disponibili anche inserti in METALLO DURO (ex: GR-INQ-0810/HM)  
HARD METAL inserts are also available (e.g. GR-INQ-0810/HM)

| Cod.        |  | Campo di lavoro (mm)<br>Working range (mm) | Campo di lavoro (pollici)<br>Working range (inches) | L2<br>(mm) | L3<br>(mm) | L4<br>(mm) | L5<br>(mm) | Compatibile solo<br>su utensile<br>Compatible only with tool |
|-------------|---|--|---|------------|------------|------------|------------|--|
| GR-INQ-0810 |   | 8mm/10mm                                   | 0,314/0,393   | 6          | 7          | 5          | 7          | PQ-810   |
| GR-INQ-1013 |   | 10mm/13mm                                  | 0,393/0,511   | 6          | 7          | 5          | 7,5        | PQ-1013  |
| GR-INQ-1316 |   | 13mm/16mm                                  | 0,511/0,629   | 10         | 8          | 6          | 12         | PQ-1316  |
| GR-INQ-1619 |   | 16mm/19mm                                  | 0,629/0,748   | 10         | 8          | 6          | 12,5       | PQ-1619  |
| GR-INQ-1927 |   | 19mm/27mm                                  | 0,748/1,062   | 13         | 13         | 10         | 17         | PQ-1927  |
| GR-INQ-2737 |   | 27mm/37mm                                  | 1,062/1,456   | 18         | 14         | 10         | 22         | PQ-2737  |

Per realizzare fori quadri interni si deve eseguire un preforo il cui diametro è dato dalla seguente formula:

$$\text{DIAMETRO PREFORO} = \text{LATO DEL QUADRO} \times 1,050$$

Ad esempio, nel caso di sede quadrata con lato 10 mm il diametro del preforo sarà: 10 mm x 1,050 = 10,50 mm