



*Wide range of components
and accessories !*

ACCESSORIES & SPARE PARTS

Motorizzati / Driven Tools

INDICE - INDEX

ATC - AUTOMATIC TOOL CHANGE

	pages
PINZE	
INTRODUZIONE INTRODUCTIONS	
PINZE ER ER COLLETS	
PINZE ER - HP ER - HP COLLETS	from 7.3 to 7.6
PINZE ER - WP ER - WP COLLETS	
PINZE ER - MR ER-MR COLLETS	
SET DI PINZE ER DIN 6499 COLLETS SET ER DIN 6499	
PINZE ET-1 ET-1 COLLETS	
GHIERE E CHIAVI	
STANDARD STANDARD	
STANDARD ESAGONALI EXAGONAL STANDARD	
ESAGONALI EXAGONAL	
MINI - MINIC MINI & MINIC	
A FORTE SERRAGGIO BALL BEARING	from 7.7 to 7.11
A SETTORI FRONTALI FRONTAL	
VITI DI CHIUSURA PORTAFRESA SHELL & MILLING CUTTER LOCK SCREW	
CHIAVI BLOCCAGGIO ALBERI LOCK SHANK WRENCHES	
UGELLI DI REFRIGERAZIONE COOLING NOZZLE	
SIRINGA PER INGRASSAGGIO SYRINGE FOR GREASING	
QUICK CHANGE	from 7.12 to 7.15
CAMBI RAPIDI MODULARI 2.0 MODULAR QUICK CHANGE ADAPTORS 2.0 <i>NEW</i>	
RECOOL	from 7.16 to 7.18
GHIERE ReCool Recool NUTS <i>NEW</i>	
DISCHETTI DI TENUTA PER GHIERE ReCool SEALING DISKS FOR ReCool nuts <i>NEW</i>	

Motorizzati / Driven Tools

ACCESSORIES

Accessori e ricambi per portautensili motorizzati !

Accessories and spare parts for driven tools !

Ampia gamma di accessori e partri di ricambio per tutta la gamma di motorizzati Gerardi. Le ghiera e le pinze sono costruite in acciaio temprato e rettificato con macchine utensili ad alta precisione.

Wide range of accessories and spare parts for all types of Gerardi driven tools. Nuts and collet are produced with top quality steel and they are hardened and grinded with high precision.



Un'ampia gamma di accessori!

Wide range of accessories!

Cambi Rapidi Quick changes

Il cambio rapido dell'utensile permette di ridurre i tempi morti della macchina. Tempi di installazione ridotti e possibilità di presetting a bordo macchina.

The quick change of preset tools shortens downtime of machine. Reduced set-up times and offline tool presetting possibility.

Ghiere ReCool Re Cool nuts

Con queste ghiera speciali è possibile ottenere il passaggio refrigerante fino a 150BAR tramite utensile anche su teste che non prevedono questa opzione

With these special nuts it is possible to get coolant through the tool (Up to 150BAR) even on angle heads which do not have this option.

Pinze ER ER Collets

Pinze ER, pinze biconiche realizzate in acciaio e adatte al serraggio di utensili secondo normativa DIN 6499

ER Collets, steel biconical collets for tool clamping according to DIN6499 regulation.

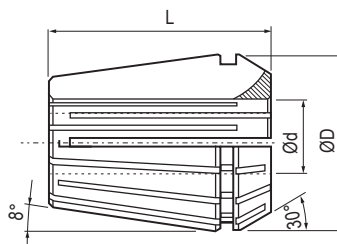

PINZE ER COLLETS ER

ER

PRECISIONE - RUN OUT
≤ 0,010

TIPO TYPE	ØD	L	Ød	PROGRESSIONE PROGRESSION	DIN	Code	
ER8	8,5	13,5	Ø1+5	0,5	6499/B	9.ER.08000 / 1 (Ø1)	
ER11	11,5	18	Ø1+7	0,5	6499/B	9.ER.11000 / 1 (Ø1)	
ER16	17	27,5	Ø1+10	0,5	6499/B	9.ER.16000 / 1 (Ø1)	
ER20	21	31,5	Ø1+13	0,5	6499/B	9.ER.20000 / 1 (Ø1)	
ER25	26	34	Ø1+16	0,5	6499/B	9.ER.25000 / 1 (Ø1)	
ER32	33	40	Ø2+20	0,5	6499/B	9.ER.32000 / 2 (Ø2)	
ER40	41	46	Ø3+30	0,5	6499/B	9.ER.40000 / 3 (Ø3)	

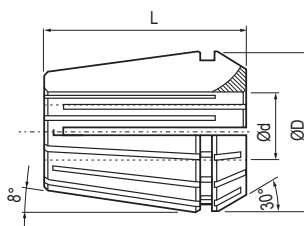
PINZE ER-HP ALTA PRECISIONE HIGH PRECISION ER-HP COLLETS

ER-HP

PRECISIONE - RUN OUT
≤ 0,005

TIPO TYPE	ØD	L	Ød	PROGRESSIONE PROGRESSION	DIN	Code	
ER8 HP	8,5	13,5	Ø1+5	0,5	6499/B	9.ER.08HP0 / 1 (Ø1)	
ER11 HP	11,5	18	Ø1+7	0,5	6499/B	9.ER.11HP0 / 1 (Ø1)	
ER16 HP	17	27,5	Ø1+10	0,5	6499/B	9.ER.16HP0 / 1 (Ø1)	
ER20 HP	21	31,5	Ø1+13	0,5	6499/B	9.ER.20HP0 / 1 (Ø1)	
ER25 HP	26	34	Ø1+16	0,5	6499/B	9.ER.25HP0 / 1 (Ø1)	
ER32 HP	33	40	Ø2+20	0,5	6499/B	9.ER.32HP0 / 2 (Ø2)	
ER40 HP	41	46	Ø3+30	0,5	6499/B	9.ER.40HP0 / 3 (Ø3)	

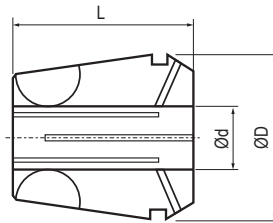
PINZE ER-WP A TENUTA STAGNA WATER PROOF ER-WP COLLETS

ER-WP

Max 40bar / 600psi
Pressione esercizio
 Working pressure

PRECISIONE - RUN OUT
≤ 0,010

TIPO TYPE	ØD	L	Ød	PROGRESSIONE PROGRESSION	DIN	Code	
ER11 WP	11,5	18	Ø1+7	0,5	6499/A	9.WP.11000 / 3 (Ø3)	
ER16 WP	17	27	Ø1+10	0,5	6499/A	9.WP.16000 / 3 (Ø3)	
ER20 WP	21	31,5	Ø2+13	0,5	6499/A	9.WP.20000 / 3 (Ø3)	
ER25 WP	26	34	Ø2+16	0,5	6499/A	9.WP.25000 / 3 (Ø3)	
ER32 WP	33	40	Ø3+20	0,5	6499/A	9.WP.32000 / 3 (Ø3)	
ER40 WP	41	46	Ø4+26	0,5	6499/A	9.WP.40000 / 4 (Ø4)	

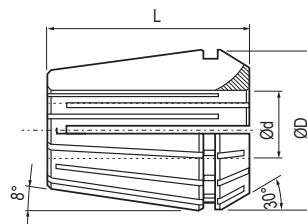
PINZE ER-MR ER - MR COLLETS

ER-MR

PRECISIONE - RUN OUT
≤ 0,002

TIPO TYPE	ØD	L	Ø	DIN	Code	
ER11 MR	17	18	1	6499	9.ER.11MR0/0...*	
			2			
			3-4-5-6			
ER16 MR	21	27,5	1	6499	9.ER.16MR0/0...*	
			2			
			3-4-5-6-8-10			
ER25 MR	33	34	1	6499	9.ER.25MR0/0...*	
			2			
			3-4-5-6-8-10-12-14-16			
ER32 MR	41	40	2	6499	9.ER.32MR0/0...*	
			3-4-5-6-8-10-12-14-16-18-20			

* Indicare sempre in fase d'ordine Ø utensile - In case of order specify the Ø tool

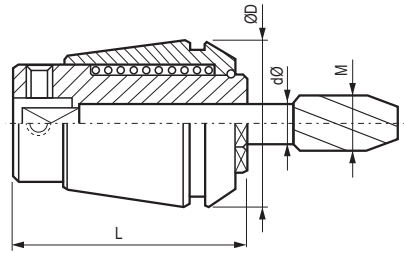
PINZE ET-1 COMPENSATE ET-1 COMPENSATED COLLETS

ET-1

TIPO TYPE	ØD	L	T	Ød	MASCHIATURA TAPPING	DIN	Code	
ET-1/16	17	27	7	Ø1,4÷6	M1-M6	6499	9.ET.16000 / 2,5 (Ø2,5)	
ET-1/20	21	31	7	Ø2,2÷7	M2-M8	6499	9.ET.20000 / 5 (Ø5)	
ET-1/25	26	34	8	Ø2,5÷10	M2-M12	6499	9.ET.25000 / 6 (Ø6)	
ET-1/32	33	43	10	Ø4,5÷12,5	M3,5-M16	6499	9.ET.32000 / 6 (Ø6)	
ET-1/40	41	54	13	Ø6÷16	M6-M16	6499	9.ET.40000 / 6 (Ø6)	

SET DI PINZE ER DIN 6499 - ISO 15788 COLLETS SET ER DIN6499 - ISO 15788



TIPO TYPE	N° PINZE # COLLETS	Ø	Code	
ER11	1 ÷ 7 - (13 Pinze - Collets)	1 - 1,5 - 2 - 2,5 - 3 - 3,5 - 4 - 4,5 - 5 - 5,5 - 6 - 6,5 - 7	9.ER.11000 / 13P	
ER16	1 ÷ 10 - (10 Pinze - Collets)	1 - 2 - 3 - 4 - 5 - 6 - 7 - 8 - 9 - 10	9.ER.16000 / 10P	
ER20	2 ÷ 13 - (12 Pinze - Collets)	2 - 3 - 4 - 5 - 6 - 7 - 8 - 9 - 10 - 11 - 12 - 13	9.ER.20000 / 12P	
ER25	2 ÷ 16 - (15 Pinze - Collets)	2 - 3 - 4 - 5 - 6 - 7 - 8 - 9 - 10 - 11 - 12 - 13 - 14 - 15 - 16	9.ER.25000 / 15P	
ER32	3 ÷ 20 - (18 Pinze - Collets)	3 - 4 - 5 - 6 - 7 - 8 - 9 - 10 - 11 - 12 - 13 - 14 - 15 - 16 - 18 - 20	9.ER.32000 / 18P	
ER40	4 ÷ 26 - (23 Pinze - Collets)	4 - 5 - 6 - 7 - 8 - 9 - 10 - 11 - 12 - 13 - 14 - 15 - 16 - 18 - 20 - 21 - 22 - 23 - 24 - 24 - 25 - 26	9.ER.40000 / 23P	

GHIERE STANDARD ESAGONALI EXAGONAL STANDARD NUTS

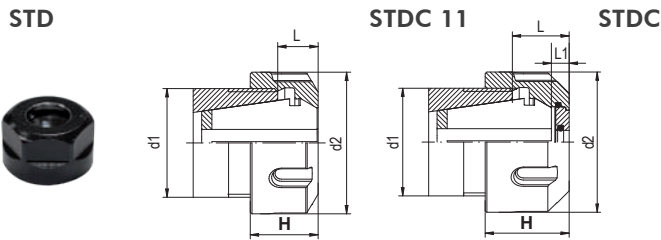
Ghiera STD/C per filetto esterno - STD/C Nut for external thread

TIPO GHIERA NUT TYPE	d1	d2	H	L	L1	Code
ER-11 STD	M14 x 0,75	19	11,3	4,9 - 6,6	-	9.ER.11STD_GDT
ER-11 STDC **			19	8,1 - 9,8	3,5	9.ER.11STDC/Ø...
ER-16 STD	M22 x 1,5	28	17,5	7 - 10,5	-	9.ER.16STD_GDT
ER-16 STDC *			25	12 - 15,5	5	9.ER.16STDC
ER-20 STD	M25 x 1,5	34	19	8 - 11,5	-	9.ER.20STD_GDT
ER-20 STDC *			34	13 - 16,5	5	9.ER.20STDC

** Dischetto di tenuta integrato, specificare Ø utensile - Sealing ring integrated, specify the Ø tool

* Per dischetti di tenuta - For sealing disks (Pag.7.18)

CHIAVI WRENCHES

Chiave per ghiera - Wrench fo nuts

CHIAVI WRENCHES	Code
CH-17 ES	9.CH.170ES
CH-25 ES	9.CH.250ES
CH-30 ES	9.CH.300ES

GHIERE STANDARD STANDARD NUTS

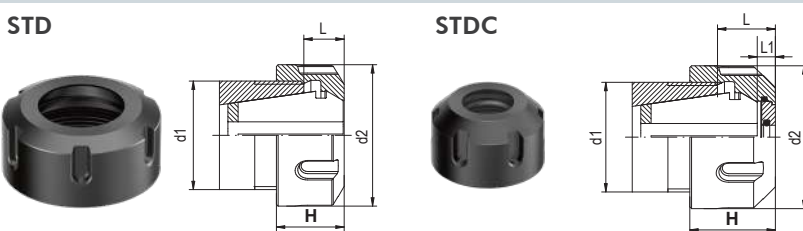
Ghiera STD/C per filetto esterno - STD/C Nut for external thread

TIPO GHIERA NUT TYPE	d1	d2	H	L	L1	Code
ER-25 STD	M32 x 1,5	42	20	8,5 - 12	-	9.ER.25STD_GDT
ER-25 STDC *			25	13,5 - 17	5	9.ER.25STDC
ER-32 STD	M40 x 1,5	50	22,5	9,5 - 13	-	9.ER.32STD_GDT
ER-32 STDC *			27,5	14,5 - 18	5	9.ER.32STDC
ER-40 STD	M50 x 1,5	63	25,5	11,5 - 15	-	9.ER.40STD_GDT
ER-40 STDC *			30,5	16,5 - 20	5	9.ER.40STDC
ER-50 STD	M64 x 2	78	35,5	14 - 21	-	9.ER.50STD_GDT
ER-50 STDC *			42,5	19 - 26	5	9.ER.50STDC

* Per dischetti di tenuta - For sealing disks (Pag.7.18)

CHIAVI WRENCHES

Chiave per ghiera - Wrench fo nuts

CHIAVI WRENCHES	Code
CH-25 STD	9.CH.25STD
CH-32 STD	9.CH.32STD
CH-40 STD	9.CH.40STD
CH-50 STD	9.CH.50STD

GHIERE MINI MINI NUTS

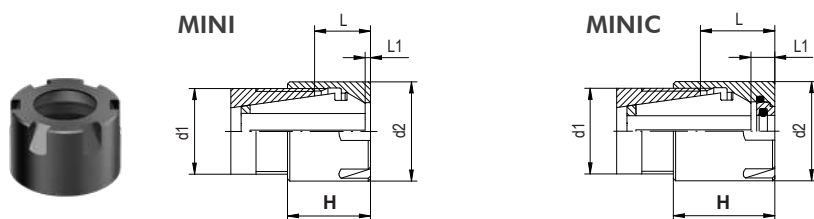

Ghiera per filetto esterno MINI/C - MINI/C Nut for external thread

TIPO GHIERA NUT TYPE	d1	d2	H	L	L1	Code	
ER-8 MINI	M10x0,75	12	10,8	4,6 - 6,1	1,5	9.ER.0800M_GDT	
ER-11 MINI	M13x0,75	16	12	5,7 - 7,5	0,4	9.ER.1100M_GDT	
ER-11 MINIC*			14,6	8,1 - 9,8	3,5	9.ER.1100MC	
ER-16 MINI	M19x1	22	18	8 - 11,5	0,9	9.ER.1600M_GDT	
ER-16 MINIC*			22	11,5 - 15	3,5	9.ER.1600MC	
ER-20 MINI	M24x1	28	19	8 - 11,5	-	9.ER.2000M_GDT	
ER-20 MINIC*			24	13 - 16,5	3,5	9.ER.2000MC	
ER-25 MINI	M30x1	35	20	8,5 - 12	-	9.ER.2500M_GDT	
ER-25 MINIC*			25	13,5 - 17	3,5	9.ER.2500MC	

* Per dischetti di tenuta - For sealing disks (Pag.7.18)

CHIAVI WRENCHES

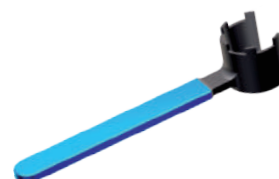

Chiave per ghiera - Wrench for nuts

CHIAVI WRENCHES	Code	
CH-8 MINI	9.CH.0800M	
CH-11 MINI	9.CH.1100M	
CH-16 MINI	9.CH.1600M	
CH-20 MINI	9.CH.2000M	
CH-25 MINI	9.CH.2500M	

GHIERE ESAGONALI EXAGONAL NUTS

ES

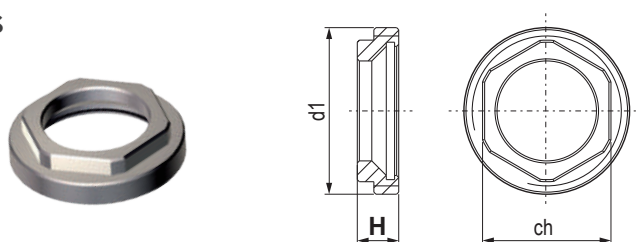

Ghiera esagonale per filetto interno ES - Hexagonal nut for internal thread ES

TIPO GHIERA NUT TYPE	d1	H	CH	Code	
ER-11 ES	M18x1	10	13	9.ER.110ES	
ER-16 ES	M24x1	11	19	9.ER.160ES	
ER-20 ES	M28x1,5	14	22	9.ER.200ES	
ER-25 ES	M32x1,5	14	27	9.ER.250ES	
ER-32 ES	M40x1,5	17,5	32	9.ER.320ES	
ER-40 ES	M50x1,5	17,1	42	9.ER.400ES	

CHIAVI WRENCHES



Chiave per ghiera - Wrench for nuts

CHIAVI WRENCHES	Code	
CH-13 ES	9.CH.130ES	
CH-19 ES	9.CH.190ES	
CH-22 ES	9.CH.220ES	
CH-27 ES	9.CH.270ES	
CH-32 ES	9.CH.320ES	
CH-42 ES	9.CH.420ES	

GHIERE A FORTE SERRAGGIO BALL BEARING NUTS

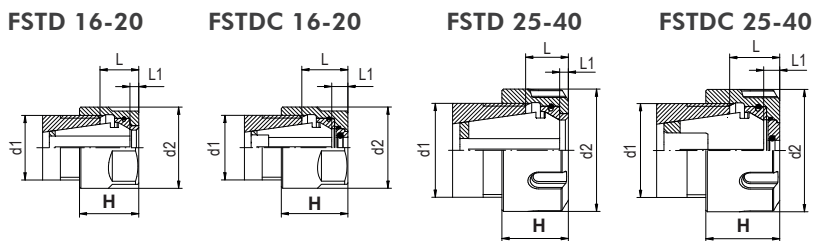

Ghiera con cuscinetto a sfera FSTD/C - FSTD/C Ball bearing nut for external thread

TIPO GHIERA NUT TYPE	d1	d2	H	L	L1	Code
ER-16 FSTD	M22x1,5	28	20,2	10 - 13,6	3	9.ER.16FSTD
ER-16 FSTDC*			22,7	12,5 - 16	5,5	9.ER.16FSTDC
ER-20 FSTD	M25x1,5	34	21,7	11 - 14,5	3	9.ER.20FSTD
ER-20 FSTDC*			24,2	13,5 - 17	5,5	9.ER.20FSTDC
ER-25 FSTD	M32x1,5	42	22,6	11,5 - 15	3	9.ER.25FSTD
ER-25 FSTDC*			25,2	14 - 17,5	5,5	9.ER.25FSTDC
ER-32 FSTD	M40x1,5	50	25	12,5 - 16	3	9.ER.32FSTD
ER-32 FSTDC*			27,4	15 - 18,5	5,5	9.ER.32FSTDC
ER-40 FSTD	M50x1,5	63	28,2	14,5 - 18	3	9.ER.40FSTD
ER-40 FSTDC*			30,7	17 - 20,5	5,5	9.ER.40FSTDC

* Per dischetti di tenuta - For sealing disks (Pag.7.18)

CHIAVI WRENCHES



Chiave per ghiera - Wrench for nuts

CHIAVI WRENCHES	Code
CH-25 ES	9.CH.250ES
CH-30 ES	9.CH.300ES
CH-25 STD	9.CH.25STD
CH-32 STD	9.CH.32STD
CH-40 STD	9.CH.40STD

GHIERE A SETTORI FRONTALI FRONTAL NUTS

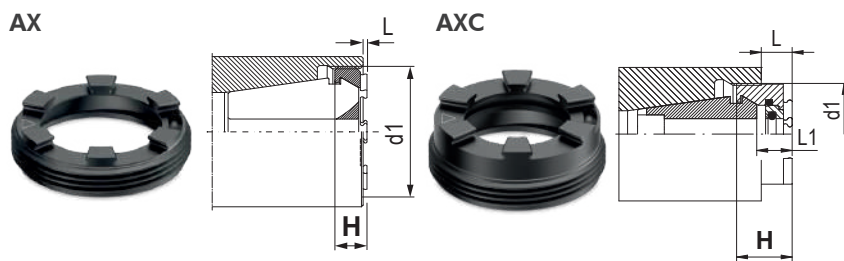

Ghiera a settori frontali per filetto interno - Frontal nut for internal thread

TIPO GHIERA NUT TYPE	d1	H	L	L1	Code
ER-11 AX	M18x1	7,5	1,0-3,2	-	9.ER.110AX
ER-11 AXC*		9,2	2,7-4,9	6,1	9.ER.110AXC
ER-16 AX	M24x1	7,6	0,0-2,6	-	9.ER.160AX
ER-16 AXC*		12,5	3,1-7,5	7,2	9.ER.160AXC
ER-20 AX	M28x1,5	8,5	0,0-2,5	-	9.ER.200AX
ER-20 AXC*		13,5	3,1-7,5	7,3	9.ER.200AXC
ER-25 AX	M32x1,5	8,8	0,0-1,9	-	9.ER.250AX
ER-25 AXC*		13,5	2,5-6,9	7,3	9.ER.250AXC
ER-32 AX	M40x1,5	9,8	0,0-1,1	-	9.ER.320AX
ER-32 AXC*		14,9	1,8-6,2	7,6	9.ER.320AXC
ER-40 AX	M50x1,5	11,7	0,0-1,0	-	9.ER.400AX
ER-40 AXC*		16,6	1,5-5,9	7,3	9.ER.400AXC

* Per dischetti di tenuta - For sealing disks (Pag.7.18)

CHIAVI WRENCHES



Chiave per ghiera - Wrench for nuts

CHIAVI WRENCHES	Code
CH-11 AX	9.CH.110AX
CH-16 AX	9.CH.160AX
CH-20 AX	9.CH.200AX
CH-25 AX	9.CH.250AX
CH-32 AX	9.CH.320AX
CH-40 AX	9.CH.400AX

VITE DI CHIUSURA LOCK SCREW

CHIAVI WRENCHES

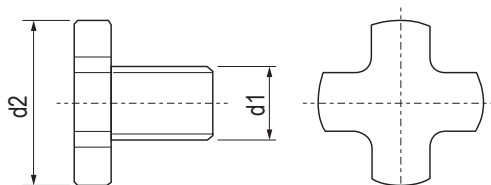
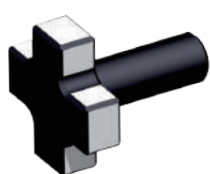

Vite di chiusura DIN6367 Portafresa - Shell end milling cutter Lock screw DIN6367

Chiave per vite di chiusura - Wrench for lock screw

VITE SCREW	d1	d2	Code	
PF-16 VT	M8	20	9.PF.160VT	
PF-22 VT	M10	28	9.PF.220VT	
PF-27 VT	M12	35	9.PF.270VT	

CHIAVI WRENCHES	Code	
CH16 PF	9.CH.160VT	
CH16 PF	9.CH.220VT	
CH16 PF	9.CH.270VT	

CHIAVI WRENCHES VDI

SEMPRE INCLUSA - ALWAYS INCLUDED

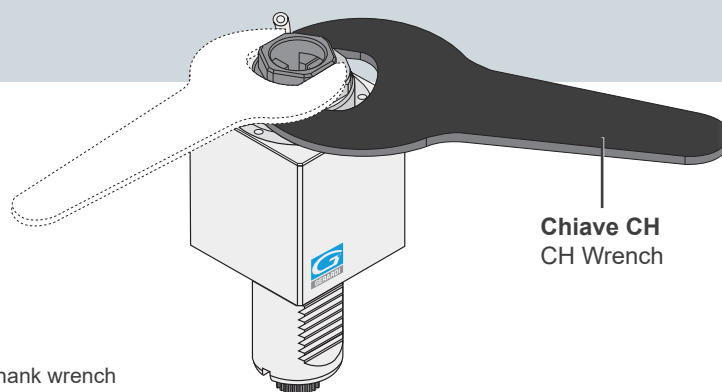



Chiave CH
CH Wrench

Chiave per bloccaggio albero motorizzato - Driven tools lock shank wrench

CHIAVI WRENCHES	ER	ch	Code	
CH-27 ES	16	27	9.CH.270ES	
CH-36 ES	20	36	9.CH.360ES	
CH-41 ES	25	41	9.CH.410ES	
CH-46 ES	32	46	9.CH.460ES	
CH-56 ES	40	56	9.CH.560ES	

Chiavi bloccaggio albero portautensile - Driven Tools shank lock wrenches

CHIAVI WRENCHES	MOTORIZZATI DRIVEN TOOLS	Code	
	4S 4 settori - 4 sectors Dmg Mori / Mazak / Miyano / Nakamura	9.CH.XXX4S	
	5S 5 settori - 5 sectors Okuma	9.CH.XXX5S	
	6S 6 settori - 6 sectors Bmt / Dmg Mori / Haas / Mazak / Miyano / Nakamura	9.CH.XXX6S	

ATTENZIONE: Prima dell'ordine specificare sempre il codice del motorizzato in vostro possesso
ATTENTION: Prima dell'ordine specificare sempre il codice del motorizzato in vostro possesso

UGELLI DI REFRIGERAZIONE COOLING NOZZLE

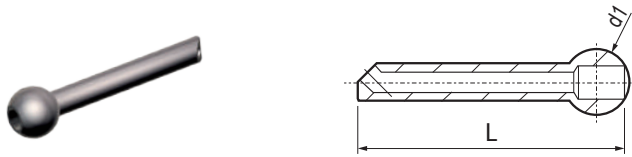

Ugello di refrigerazione - Cooling nozzle

d1	L	Code	
Ø12	18	9.RF.12180	
Ø12	38	9.RF.12380	
Ø12	49	9.RF.12490	

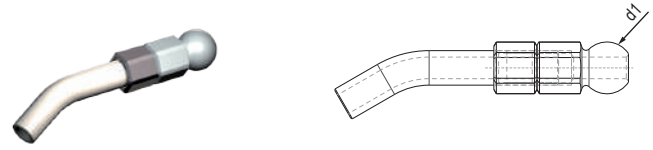

Ugello di refrigerazione Cooling nozzle

d1	Code	
Ø11	9.18.00011 *	

* Fino ad esaurimento scorte

* While stocks last



Sfera ugello - Nozzle ball pin

d1	d2	Code	
Ø9	M4	9.17.900M4	
Ø10	M5	9.17.900M5	
Ø12	M8	9.17.900M8	

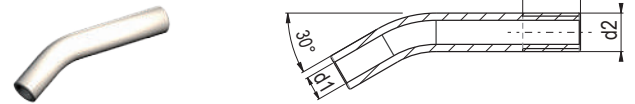

Prolunga per ugello di refrigerazione

Cooling nozzle extensions

d1	d2	Code	
Ø2,5	M4	9.18.100M4	
Ø3	M5	9.18.100M5	
Ø5	M8	9.18.100M8	

SIRINGA PER INGRASSAGGIO SYRINGE FOR GREASING

Sistema di ingrassaggio rapido mediante siringa specifico per la lubrificazione degli ingranaggi delle teste angolari.

Quick greasing system through syringe. Designed specifically for the lubrication of Angle Heads' gears.

MODELLO MODEL	CAPACITÀ CAPACITY	Code	
Siringa grasso Grease syringe	30ml	9.FA.018055	
Tubetto grasso 2 Ep Grease tube 2 Ep	50ml	GLU037701	



MODULAR QUICK CHANGE ADAPTORS

NEW 2026

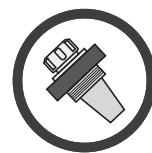

COMPATIBILI CON TUTTE LE USCITE ER - COMPATIBLE WITH ALL ER OUTPUTS

I cambi rapidi modulari Gerardi mantenendo il presetting precedentemente realizzato consentono un notevole risparmio dei costi ed un ottimizzazione dei tempi di allestimento macchina. Sono perfettamente compatibili con tutti i motorizzati e le teste angolari aventi uscita ER DIN6499 e possono essere utilizzati sia con refrigerante interno che esterno.

The Gerardi modular quick change adaptors keep the tool presetting previously made and allow great costs and minimum machine set up times. They are perfectly compatible with all driven tools and angle head with ER DIN6499 output and they can be used with internal or external coolant.



Prestazioni garantite, maggior rigidità ed una miglior trasmissione di coppia grazie alla losanga di trascinamento rimovibile e alla ghiera con cuscinetto a sfera.

Guaranteed rigidity, high performances and the best transmission thanks to the removable diamond plate and the ball bearing nut.

ER OUTPUTS COMPATIBLE

2 YEARS GUARANTEED

100% MADE IN ITALY

10.000Rpm
MAX SUGGESTED

Q MODULAR QUICK CHANGE ADAPTORS 2.0

NEW 2026



COMPATIBILI CON TUTTE LE USCITE ER - COMPATIBLE WITH ALL ER OUTPUTS

SISTEMA MODULARE MODULAR SYSTEM



Facile e veloce sistema modulare universale per cambiare rapidamente diverse tipologie di utensili.

An easy modular system to replace quickly any tool you need.

VANTAGGI ADVANTAGES



Aiutano a ridurre i costi-extra per l'acquisto di nuovi motorizzati o teste angolari.

The costs for further requirements of spindle units can be reduced by using the universal quick change adaptors

ALTE PRESTAZIONI HIGH PERFORMANCE



Ghiera con cuscinetto a sfera e losanga di trascinamento removibile per una maggiore rigidità.

High rigidity thanks to the ball bearing nut and the removable diamond plate

COMPATIBILITÀ COMPATIBILITY



Ampia gamma di uscite disponibili adatte al montaggio su qualsiasi tipologia di motorizzato o testa angolare con uscita ER

Wide range of outputs available. Ball bearing nut and removable diamond plate for highest rigidity.

- Nuovi cambi rapidi modulari 2.0 a FORTE SERRAGGIO, 100% Made in Italy.
- Prestazioni garantite e maggior rigidità sui motorizzati Gerardi grazie alla losanga di trascinamento (rimovibile) e alla ghiera con cuscinetto a sfera.
- Adattabili a motorizzati con uscita refrigerante sia interna che esterna.
- Si consiglia di non superare i 10.000 Rpm utilizzando i cambi rapidi

- Universal HIGH TORQUE modular quick change adaptor 100% Made in Italy.
- Guaranteed higher rigidity and performances on Gerardi driven tools thanks to the removable diamond plate and the ball bearing nut.
- Suitable for ER toolholder with external and internal coolant supply
- Using the quick change adaptors, we suggest not to exceed 10.000 Rpm

PER GHIERE INTERNE CON FILETTO ESTERNO FOR INTERNAL NUTS WITH EXTERNAL THREAD



PER GHIERE ESTERNE CON FILETTO INERNO FOR EXTERNAL NUTS WITH INTERNAL THREAD

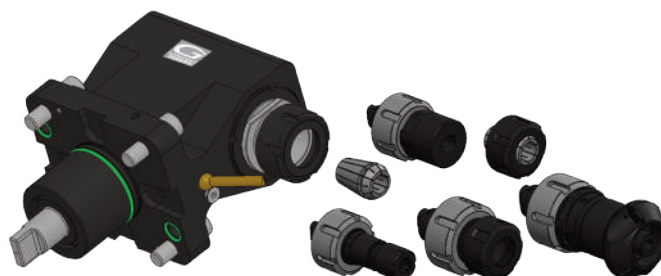

Passaggio Refrigerante Sempre Disponibile
Internal Coolant Always Available

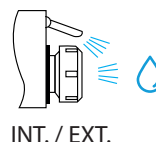
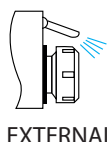



MODULAR QUICK CHANGE ADAPTORS



Per Ghiere Interne con Filetto Esterno
For Internal Nuts with External Thread



Passaggio Refrigerante Sempre Disponibile
Internal Coolant Always Available



EXTERNAL

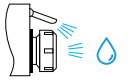

INT. / EXT.

ART. 182A PORTAPINZA - COLLET CHUCK

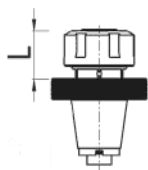

ENTRATA INPUT	L	USCITA OUTPUT	Code
ER25	29	ER 16	9.HT.ER25I.16E
	31	ER 25	9.HT.ER25I.25E
ER32	29	ER 20	9.HT.ER32I.20E
	31	ER 25	9.HT.ER32I.25E
	35	ER 32	9.HT.ER32I.32E
ER40	35	ER 32	9.HT.ER40I.32E
	40	ER 40	9.HT.ER40I.40E

ART. 182E PORTAPINZA - COLLET CHUCK

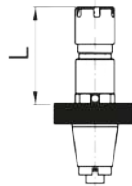

ENTRATA INPUT	L	USCITA OUTPUT	Code
ER25	40	ER 16 MINI	9.HT.ER25I.16EL
	40	ER 11 MINI	9.HT.ER32I.11EL
ER32	50	ER 16 MINI	9.HT.ER32I.16EL
	50	ER 20 MINI	9.HT.ER32I.20EL
ER40	50	ER 16 MINI	9.HT.ER40I.16EL
	50	ER 20 MINI	9.HT.ER40I.20EL
	50	ER 25 MINI	9.HT.ER40I.25EL

ART. 182D PORTAPINZA - COLLET CHUCK

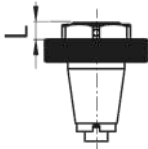

ENTRATA INPUT	L	USCITA OUTPUT	Code
ER25	11	ER 16	9.HT.ER25I.16I
ER40	14	ER 32	9.HT.ER40I.32I

ART. 182C PORTA WELDON
CLAMPING CHUCK FOR ROUND SHAFT (Weldon)

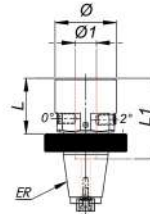

ENTRATA INPUT	L L1		Ø1 Ø		Code
	(mm)				
ER25	28	36	8	21	9.HT.ER25I.W08
	29	40	10	28	9.HT.ER25I.W10
	31	45	12	34	9.HT.ER25I.W12
	31	45	14	36	9.HT.ER25I.W14
ER32	28	36	8	21	9.HT.ER32I.W08
	29	40	10	28	9.HT.ER32I.W10
	31	45	12	34	9.HT.ER32I.W12
	34	49	16	38	9.HT.ER32I.W16
ER40	36	51	20	45	9.HT.ER32I.W20
	29	40	10	28	9.HT.ER40I.W10
	31	45	12	34	9.HT.ER40I.W12
ER40	34	49	16	38	9.HT.ER40I.W16
	36	51	20	45	9.HT.ER40I.W20

ART. 182B PORTAFRESA - SHELL END MILL CUTTER *

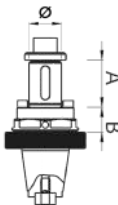

ENTRATA INPUT	A B		USCITA OUTPUT	Code
	(mm)			
ER25	27	16	Ø16	9.HT.ER25I.P16R
	31	16	Ø22	9.HT.ER25I.P22R
ER32	27	17	Ø16	9.HT.ER32I.P16R
	31	17	Ø22	9.HT.ER32I.P22R
ER40	31	20	Ø22	9.HT.ER40I.P22R
	-	-	Ø27	9.HT.ER40I.P27R

ART. 182K MASTER PER ALLINEAMENTO
MASTER CONTROL PIN

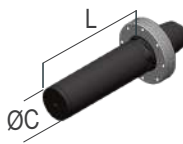

ENTRATA INPUT	L	USCITA OUTPUT	Code
ER25	95	Ø25	9.HT.ER25I.95MC
ER32	105	Ø30	9.HT.ER32I.105MC
ER40	105	Ø30	9.HT.ER40I.105MC

ART. 182M MASTER PER ALLINEAMENTO
MASTER CONTROL PIN

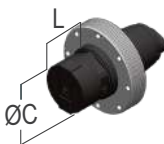

ENTRATA INPUT	L	USCITA OUTPUT	Code
ER25	25	Ø25	9.HT.ER25I.25MP
ER40	45	Ø30	9.HT.ER40I.30MP

ART. 182Q DISPOSITIVO PER MONTAGGIO
CAMBI RAPIDI DA PRESETTARE
QUICK CHANGE PRESETTING

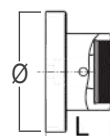

ENTRATA INPUT	L	USCITA OUTPUT	Code
Ø77	41	ER25	9.HT.ER25.IP
Ø87	46	ER32	9.HT.ER32.IP
Ø85	47	ER40	9.HT.ER40.IP

Q MODULAR QUICK CHANGE ADAPTORS 2.0

Per Ghiere Esterne con Filetto Interno
For External Nuts with Internal Thread

Passaggio Refrigerante Sempre Disponibile
Internal Coolant Always Available

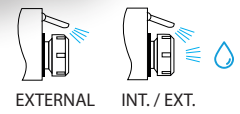

ART. 183A PORTAPINZA - COLLET CHUCK

ENTRATA INPUT	L	USCITA OUTPUT	Code
ER25	29	ER 16	9.HT.ER25E.16E
	31	ER 20	9.HT.ER25E.20E
	31	ER 25	9.HT.ER25E.25E
ER32	29	ER 20	9.HT.ER32E.20E
	31	ER 25	9.HT.ER32E.25E
	35	ER 32	9.HT.ER32E.32E
ER40	31	ER 25	9.HT.ER40E.25E
	35	ER 32	9.HT.ER40E.32E
	40	ER 40	9.HT.ER40E.40E

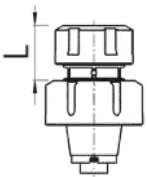

ART. 183E PORTAPINZA - COLLET CHUCK

ENTRATA INPUT	L	USCITA OUTPUT	Code
ER25	30	ER 11 MINI	9.HT.ER25E.11EL
	40	ER 16 MINI	9.HT.ER25E.16EL
ER32	40	ER 11 MINI	9.HT.ER32E.11EL
	50	ER 16 MINI	9.HT.ER32E.16EL
	50	ER 20 MINI	9.HT.ER32E.20EL
ER40	50	ER 16 MINI	9.HT.ER40E.16EL
	50	ER 20 MINI	9.HT.ER40E.20EL
	50	ER 25 MINI	9.HT.ER40E.25EL

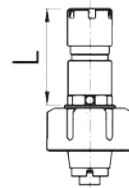

ART. 183D PORTAPINZA - COLLET CHUCK

ENTRATA INPUT	L	USCITA OUTPUT	Code
ER25	9	ER 11	9.HT.ER25E.111
	11	ER 16	9.HT.ER25E.161
ER32	11	ER 20	9.HT.ER32E.201
	11	ER 25	9.HT.ER32E.251
ER40	12	ER 25	9.HT.ER40E.251
	14	ER 32	9.HT.ER40E.321

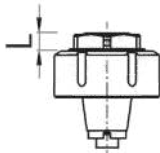

ART. 183C PORTA WELDON - CLAMPING CHUCK FOR ROUND SHAFT (Weldon)

ENTRATA INPUT	L	L1	Ø1		Code
			(mm)	Ø	
ER25	28	36	8	21	9.HT.ER25E.W08
	29	40	10	28	9.HT.ER25E.W10
	31	45	12	34	9.HT.ER25E.W12
ER32	28	36	8	21	9.HT.ER32E.W08
	29	40	10	28	9.HT.ER32E.W10
	31	45	12	34	9.HT.ER32E.W12
ER40	34	49	16	38	9.HT.ER32E.W16
	36	51	20	45	9.HT.ER32E.W20
	28	36	8	21	9.HT.ER40E.W08
ER40	29	40	10	28	9.HT.ER40E.W10
	31	45	12	34	9.HT.ER40E.W12
	34	49	16	38	9.HT.ER40E.W16
	36	51	20	45	9.HT.ER40E.W20

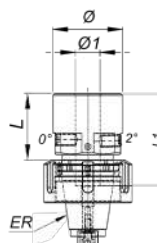

ART. 183B PORTAFRESA - SHELL END MILL CUTTER *

ENTRATA INPUT	A	B	USCITA OUTPUT	Code
	(mm)			
ER25	27	16	Ø16	9.HT.ER25E.P16R
	31	16	Ø22	9.HT.ER25E.P22R
ER32	27	17	Ø16	9.HT.ER32E.P16R
	31	17	Ø22	9.HT.ER32E.P22R
ER40	31	20	Ø22	9.HT.ER40E.P22R

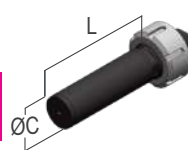
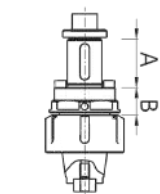

ART. 183K MASTER PER ALLINEAMENTO MASTER CONTROL PIN

ENTRATA INPUT	L	USCITA OUTPUT	Code
ER25	95	Ø25	9.HT.ER25E.95MC
ER32	105	Ø30	9.HT.ER32E.105MC
ER40	105	Ø30	9.HT.ER40E.105MC



ART. 183M MASTER PER ALLINEAMENTO MASTER CONTROL PIN

ENTRATA INPUT	L	USCITA OUTPUT	Code
ER25	25	Ø25	9.HT.ER25E.25MP
ER40	45	Ø30	9.HT.ER40E.30MP



ART. 183P DISPOSITIVO PER MONTAGGIO CAMBI RAPIDI DA PRESETTARE QUICK CHANGE PRESETTING

ENTRATA INPUT	L	USCITA OUTPUT	Code
Ø65	37	ER25	9.HT.ER25.EP
Ø75	42	ER32	9.HT.ER25.EP
Ø85	47	ER40	9.HT.ER40.EP

RE COOL NUTS

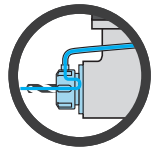
REGO-FIX

SISTEMA RECOOL PER GHIERE ESTERNE E MINI RECOOL SYSTEM FOR EXTERNAL NUTS AND MINI

APPLICAZIONE RAPIDA E FACILE DELLA REFRIGERAZIONE INTERNO DALL'ESTERNO
REASONABLE FAST AND EASY CONVERSION TO INTERNAL COOLANT

CARATTERISTICHE PRINCIPALI: KEY FEATURES:

- Refrigerazione ottimale del tagliente: prolungata vita utile degli utensili, ridotti tempi di lavorazione.
- ottima evacuazione del truciolo
- Totale assenza di dispersione di lubrorefrigerante
- Refrigerazione interna o periferica con i dischetti a tenuta stagna (7.18)
- Optimized coolant supply to the cutting edge: increases tool life and reduces cycle time
- Best chip removal
- No scattering or spray losses
- Internal or peripheral coolant through sealing disks (Pag. 7.18)

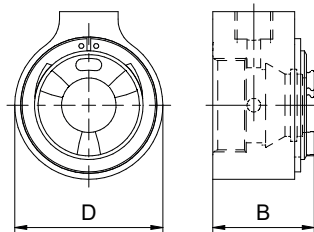

Dotazione Standard

- Ghiera ReCool ER 11-40
- Tubo refrigerante Ø6, 400mm
- 2 Raccordi dritti da 1/8"
- 2 Raccordi a 90° da 1/8"

Standard equipment:

- ReCool nut ER 11-40
- Coolant pipe Ø6, 400mm
- 2 Fitting 1/8" straight
- 2 Fitting 1/8" 90° elbow
- Ghiera ReCool ER Mini 11-25
- Tubo refrigerante Ø6, 400mm
- 2 Raccordi dritti da 1/8"
- 2 Raccordi a 90° da 1/8"
- ReCool nut ER Mini 11-25
- Coolant pipe Ø6, 400mm
- 2 Fitting 1/8" straight
- 2 Fitting 1/8" 90° elbow



Lubrorefrigerazione esterna tradizionale
Standard flood cooling

Dischetto a tenuta stagna
Sealing disks (EXTRA)

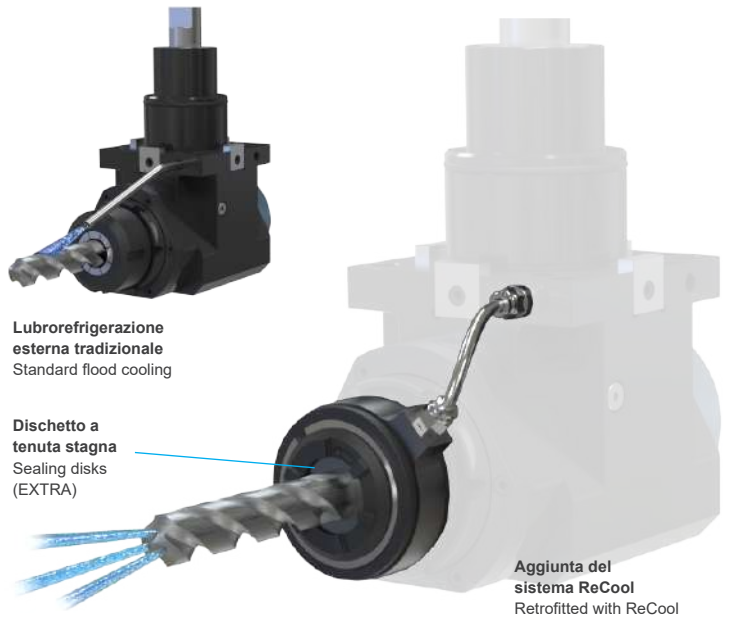

Aggiunta del sistema ReCool
Retrofitting with ReCool

Ghiere STD STD Nuts	Codice Code	Dimensions mm		Filetto Thread	Chiave Screw (EXTRA)*
		B	D		
GRCR 11	9.GR.CR11	16,6	21,75	M 14 X 0,75	9.CH.11AX
GRCR 16	9.GR.CR16	24,5	34	M 22 X 1,5	9.CH.16AX
GRCR 20	9.GR.CR20	26	40	M 25 x 1,5	9.CH.20AX
GRCR 25	9.GR.CR25	27	50	M 32 x 1,5	9.CH.25AX
GRCR 32	9.GR.CR32	29,5	62,5	M 40 x 1,5	9.CH.32AX
GRCR 40	9.GR.CR40	32,5	72,5	M 50 x 1,5	9.CH.40AX

Ghiere MINI MINI Nuts	Codice Code	Dimensions mm		Filetto Thread	Chiave Screw (EXTRA)*
		B	D		
GRCRM 11	9.GR.CRM11	16,6	21,75	M 13 X 0,75	9.CH.11AX
GRCRM 16	9.GR.CRM16	24,5	31	M19 X 1	9.CH.16AX
GRCRM 20	9.GR.CRM20	26	38	M 24 x 1	9.CH.20AX
GRCRM 25	9.GR.CRM25	27	46	M 30 x 1	9.CH.25AX

*Vedi pag. 7.9 / See pages 7.9

PARAMETRI TECNICI TECHNICAL DATA

I seguenti parametri si applicano al ReCool:

- Velocità di rotazione max.: 12 000 rpm (6000 rpm con ER40)
- Pressione lubrificante max.: 150 bar / 2175 PSI* (con tubo ad alta pressione)
- Pressione lubrificante min.: in base alla velocità di rotazione (vedi tabella)

The following parameters apply to ReCool:

- Max. Rotation speed: 12,000 rpm (6000 rpm with ER40)
- Max. Coolant pressure: 150 bar/2175 PSI* (with high pressure hose)
- Min. Coolant pressure: depending on the rotational speed (see table)

	Tipo di ghiera Nut type	≤3000 Rpm	≤6000 Rpm	≤9000 Rpm	≤12000 Rpm
Minimum pressure	GRCR 11/ GRCRM 11	5 bar / 73 PSI	7,5 bar / 109 PSI	10 bar / 145 PSI	15 bar / 218 PSI
	GRCR 16 / GRCRM 16	5 bar / 73 PSI	7,5 bar / 109 PSI	10 bar / 145 PSI	15 bar / 218 PSI
	GRCR 20 / GRCRM 20	5 bar / 73 PSI	7,5 bar / 109 PSI	10 bar / 145 PSI	15 bar / 218 PSI
	GRCR 25 / GRCRM 25	5 bar / 73 PSI	7,5 bar / 109 PSI	10 bar / 145 PSI	15 bar / 218 PSI
	GRCR 32	5 bar / 73 PSI	7,5 bar / 109 PSI	10 bar / 145 PSI	15 bar / 218 PSI
	GRCR 40	5 bar / 73 PSI	7,5 bar / 109 PSI	-	-

I tubi ed i connettori forniti sono progettati e testati per una pressione del lubrificante massima di 100bar / 1450 PSI. Per pressioni superiori sono obbligatori i tubi ad alta pressione.
The supplied hose and fittings are designed and tested for maximum coolant pressure of 100 bar /1450 PSI. For higher coolant pressures the High-pressure hose is mandatory

RE COOL NUTS

REGO-FIX▲

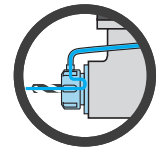

SISTEMA RECOOL PER GHIERE INTERNE RECOOL SYSTEM FOR INTERNAL NUTS

APPLICAZIONE RAPIDA E FACILE DELLA REFRIGERAZIONE INTERNO DALL'ESTERNO
REASONABLE FAST AND EASY CONVERSION TO INTERNAL COOLANT

CARATTERISTICHE PRINCIPALI: KEY FEATURES:

- Refrigerazione ottimale del tagliente: prolungata vita utile degli utensili, ridotti tempi di lavorazione.
- ottima evacuazione del truciolo
- Totale assenza di dispersione di lubrorefrigerante
- Refrigerazione interna o periferica con i dischetti a tenuta stagna (7.18)
- Optimized coolant supply to the cutting edge: increases tool life and reduces cycle time
- Best chip removal
- No scattering or spray losses
- Internal or peripheral coolant through sealing disks (Pag. 7.18)

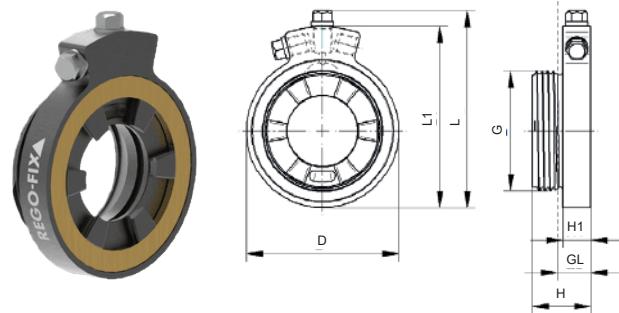

Dotazione Standard
- Ghiera ReCool ER 16-32

Standard equipment:
- ReCool nut ER 16-32

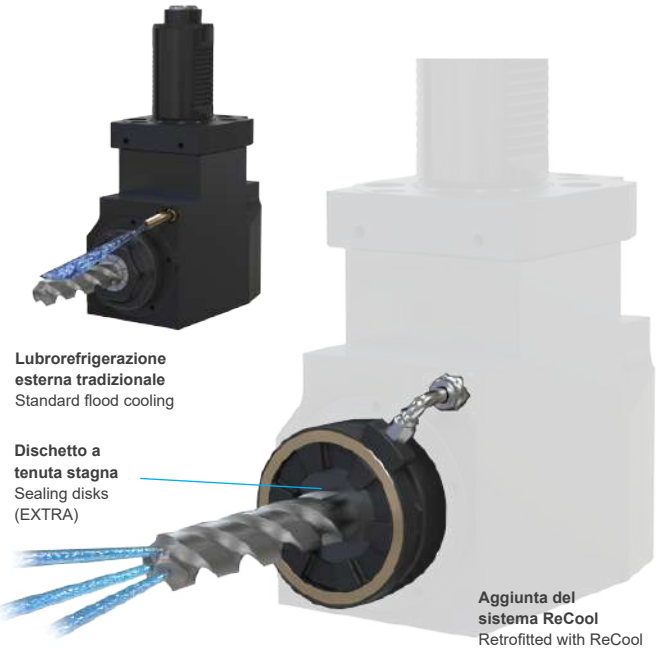

Tipo di ghiera Nut type	Codice Code	Dimensions mm						Filetto Thread	Chiave Screw (EXTRA)*
		D	L	L1	H	H1	GL		
GRCRX 16	9.GR.CR16	34	46	41,5	14,5	7,6	9	M 24 X 1	9.CH.16AX
GRCRX 20	9.GR.CR20	37,5	49	45	15,5	7,6	9	M 28 x 1,5	9.CH.20AX
GRCRX 25	9.GR.CR25	41	53	48,5	15,8	7,6	9	M 32 x 1,5	9.CH.25AX
GRCRX 32	9.GR.CR32	49	61	56,5	16,9	7,6	9	M 40 x 1,5	9.CH.32AX

*Vedi pag. 7.9 / See pages 7.9

Accessori ReCool ReCool Accessories		Codice Code	Lunghezza mm Length mm	Filetto Thread
	Tubo refrigerante flessibile Flex coolant pipe	9.GR.HSAX080	80	-
		9.GR.HSAX100	100	-
		9.GR.HSAX120	120	-
	Vite di raccordo per tubo Ø6 Hollow bolt set for Ø6 pipe	9.GH.S610RF6	-	M6 x 1

PARAMETRI TECNICI TECHNICAL DATA

I seguenti parametri si applicano al ReCool:
Velocità di rotazione max.: 12 000 rpm (6000 rpm con ER40)
Pressione lubrificante max.: 100 bar / 2175 PSI
Pressione lubrificante min.: in base alla velocità di rotazione (vedi tabella)

The following parameters apply to ReCool:
Max. Rotation speed: 12,000 rpm (6000 rpm with ER40)
Max. Coolant pressure: 100 bar/2175 PSI* (with high pressure hose)
Min. Coolant pressure: depending on the rotational speed (see table)

Tipo di ghiera Nut type	≤3000 Rpm	≤6000 Rpm	≤9000 Rpm	≤12000 Rpm
GRCRX 16	5 bar / 73 PSI	7,5 bar / 109 PSI	10 bar / 145 PSI	15 bar / 218 PSI
GRCRX 20	5 bar / 73 PSI	7,5 bar / 109 PSI	10 bar / 145 PSI	15 bar / 218 PSI
GRCRX 25	5 bar / 73 PSI	7,5 bar / 109 PSI	10 bar / 145 PSI	15 bar / 218 PSI
GRCRX 32	5 bar / 73 PSI	7,5 bar / 109 PSI	10 bar / 145 PSI	15 bar / 218 PSI

RE COOL NUTS

REGO-FIX

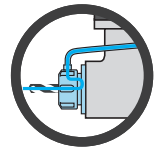

DISCHETTI A TENUTA STAGNA PER GHIERE - SEALING DISKS FOR NUTS

REFRIGERAZIONE INTERNA - INTERNAL COOLANT

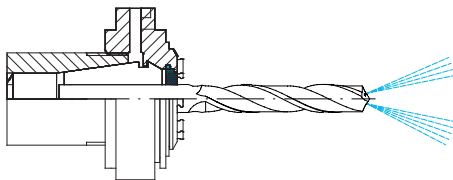
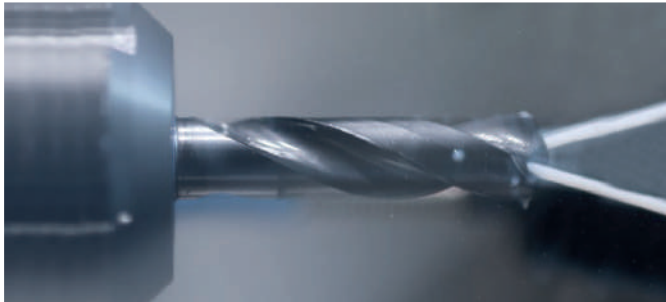

GDS



CARATTERISTICHE PRINCIPALI - KEY FEATURES

- Facile aggiunta della lubrorefrigerazione interna con Ghiera ReCool, con il dischetto a tenuta stagna GDS
- Precisa refrigerazione del tagliente e migliore asportazione di truciolo
- Ideale soprattutto per elevate profondità
- Lubrificazione e refrigerazione del tagliente
- Ottima finitura superficiale

- Achieve internal cooling with ReCool nuts and the use of our sealing disk GDS
- Precise cooling at the cutting edge and improved chip removal
- Particularly suitable for deep cavities
- Lubrication of cutting edge and cooling
- Best surface quality

GDS

Disco di tenuta
Sealing ring



Disco Ring	Codici Code	
GDS11	9.GD.S11/...*	
GDS16	9.GD.S16/...*	
GDS20	9.GD.S20/...*	
GDS25	9.GD.S25/...*	
GDS32	9.GD.S32/...*	
GDS40	9.GD.S40/...*	

* Indicare sempre in fase d'ordine Ø utensile
* In case of order specify the Ø tool

STDC

Ghiera STDC
STDC Nut



Ghiera Nut	H	Codici Code
ER-11 STDC*	14,6	9.ER.11STDC
ER-16 STDC	22,5	9.ER.16STDC
ER-20 STDC	24	9.ER.20STDC
ER-25 STDC	25	9.ER.25STDC
ER-32 STDC	27,5	9.ER.32STDC
ER-40 STDC	30,5	9.ER.40STDC

* Dischetto di tenuta integrato
* Sealing ring integrated

MINIC

Ghiera MINIC
MINIC Nut



Ghiera Nut	H	Codici Code
ER-11 MINIC	14,6	9.ER.1100MC
ER-16 MINIC	22,5	9.ER.1600MC
ER-20 MINIC	24	9.ER.2000MC
ER-25 MINIC	25	9.ER.2500MC
-	-	-
-	-	-

AXC

Ghiera a settori frontali
Frontal nut



Ghiera Nut	H	Codici Code
ER-11 AXC	7,5	9.ER.110AXC
ER-16 AXC	7,6	9.ER.160AXC
ER-20 AXC	8,5	9.ER.200AXC
ER-25 AXC	8,8	9.ER.250AXC
ER-32 AXC	9,8	9.ER.320AXC
ER-40 AXC	11,7	9.ER.400AXC

REFRIGERAZIONE PERIFERICA - PERIPHERAL COOLANT

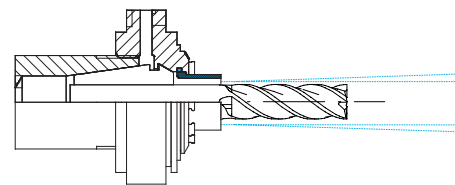
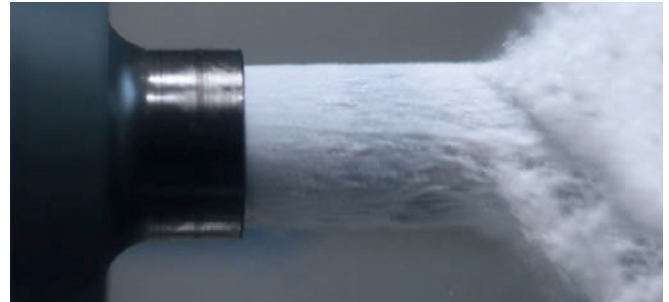

GKS



CARATTERISTICHE PRINCIPALI - KEY FEATURES

- Facile aggiunta della lubrorefrigerazione periferica con Ghiera ReCool, con il dischetto per refrigerazione GKS
- Lubrorefrigerante lungo l'utensile fino al tagliente
- Ideale per profondità medie
- Applicabile su teste e motorizzati con refrigerante interno con apposita ghiera STDC - MINIC - AXC

- Achieve peripheral cooling with ReCool nuts and the use of our coolant flush disk GKS
- Coolant is fed along the side of the tool to the cutting edge
- Can be used for moderate cavities
- Applicable on Angle Heads and Driven Tools with internal coolant through suitable nut

GKS

Disco di tenuta
Sealing ring



Disco Ring	Codici Code	
-	-	
GKS16	9.GK.S16/...*	
GKS20	9.GK.S20/...*	
GKS25	9.GK.S25/...*	
GKS32	9.GK.S32/...*	
-	-	

* Indicare sempre in fase d'ordine Ø utensile
* In case of order specify the Ø tool

STDC

Ghiera STDC
STDC Nut



Ghiera Nut	H	Codici Code
-	-	-
ER-16 STDC	32	9.ER.16STDC
ER-20 STDC	35	9.ER.20STDC
ER-25 STDC	42	9.ER.25STDC
ER-32 STDC	50	9.ER.32STDC
-	-	-

MINIC

Ghiera MINIC
MINIC Nut



Ghiera Nut	H	Codici Code
-	-	-
ER-16 MINIC	12	9.ER.1600MC
ER-20 MINIC	18	9.ER.2000MC
ER-25 MINIC	20	9.ER.2500MC
-	-	-
-	-	-

AXC

Ghiera a settori frontali
Frontal nut



Ghiera Nut	H	Codici Code
-	-	-
ER-16 AXC	7,6	9.ER.160AXC
ER-20 AXC	8,5	9.ER.200AXC
ER-25 AXC	8,8	9.ER.250AXC
ER-32 AXC	9,8	9.ER.320AXC
-	-	-

Per maggiori informazioni vedi pag. 7.7 - 7.9 - For more infos see pages 7.7 - 7.9